

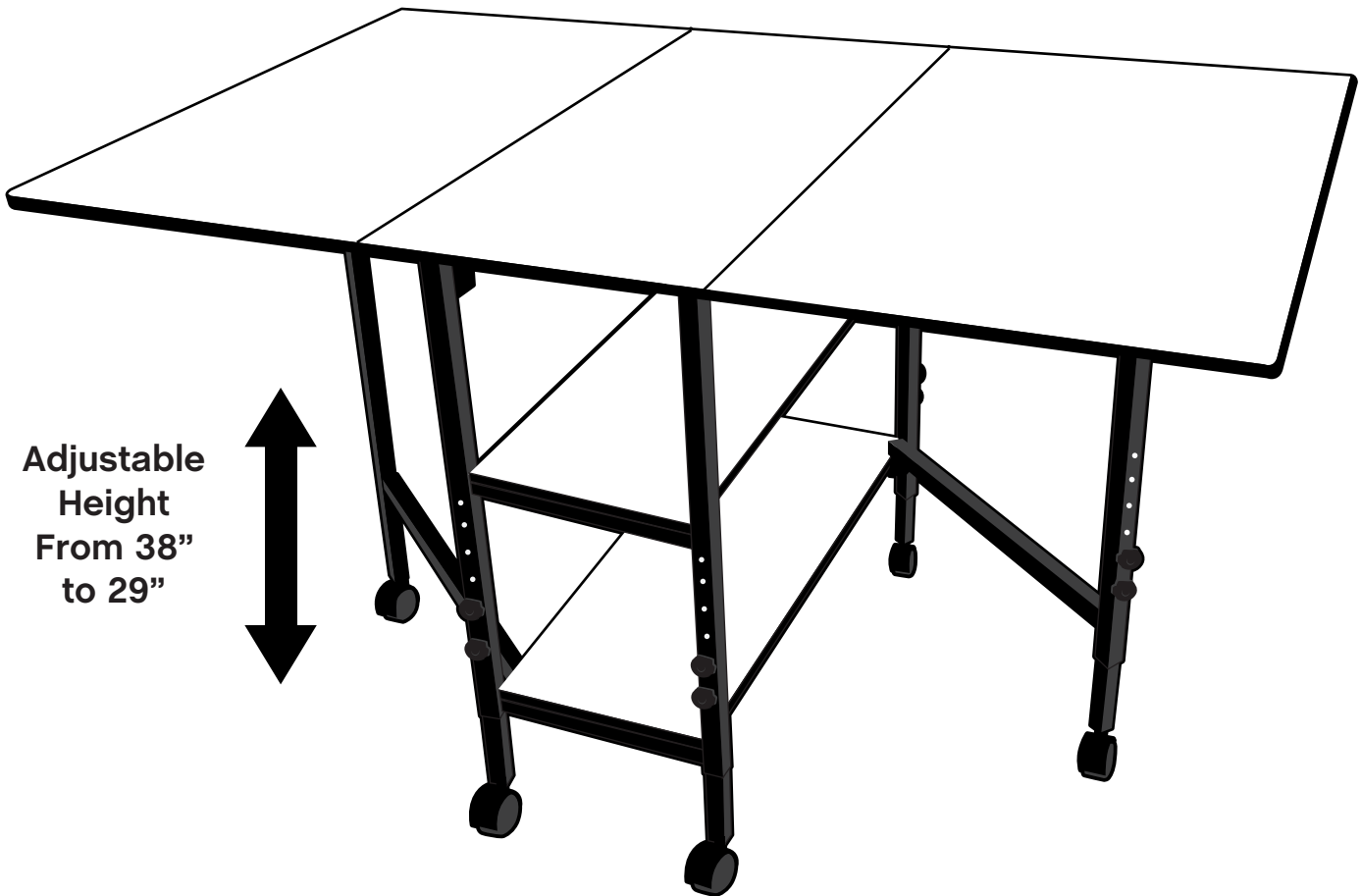


Item No. 38431

# ADJUSTABLE

## Home Hobby & Craft Table

### Assembly Instructions



Adjustable  
Height  
From 38"  
to 29"

[www.sullivans.net/usa](http://www.sullivans.net/usa)



# ADJUSTABLE Home Hobby & Craft Table Parts List



**Tools Needed:**  
Phillips Head Screwdriver

**Assembly time:**  
Aprox. 50 minutes

**A. PHILLIPS HEAD SCREWS**  
0.5" - 4 pcs.



**B. HEX-HEAD SCREW**  
0.5" - 24 pcs.



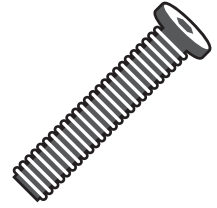
**C. HEX-HEAD SCREW**  
1.25" - 15 pcs.



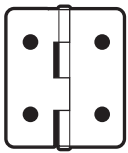
**D. HEX-HEAD SCREW**  
1.75" - 6 pcs.



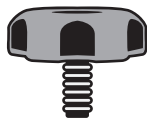
**E. HEX-HEAD SCREW**  
2" - 4 pcs.



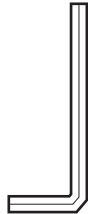
**F. HINGES**  
6 pcs.



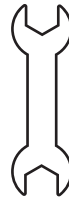
**G. ADJUSTING KNOB**  
12 pcs.



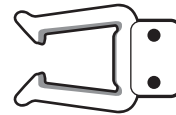
**H. ALLEN KEY**  
1 pcs.



**I. OPEN END WRENCH**  
1 pc.



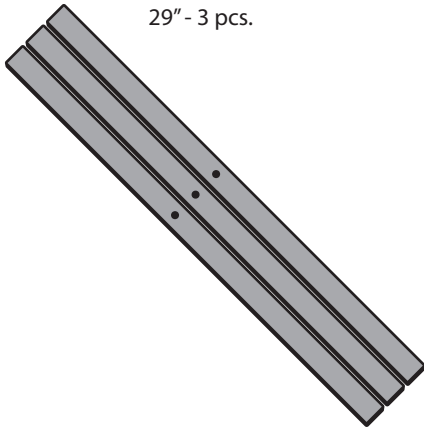
**J. STOPS**  
2 pcs.



**K1. CASTERS - K2. LOCKING CASTERS**  
4 pcs. - 2 pcs.



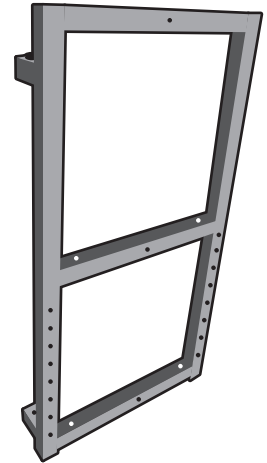
**L. LONG BEAMS**  
29" - 3 pcs.



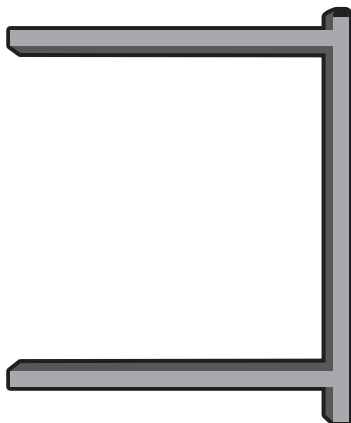
**M. SHORT BEAMS**  
6 pcs.



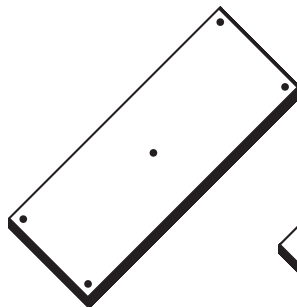
**N. RECTANGULAR BODY**  
22" x 26.5" 2 pcs.



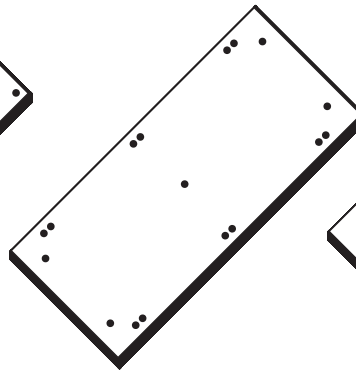
**O. SWING ARMS**  
22" x 26.5" - 2 pcs.



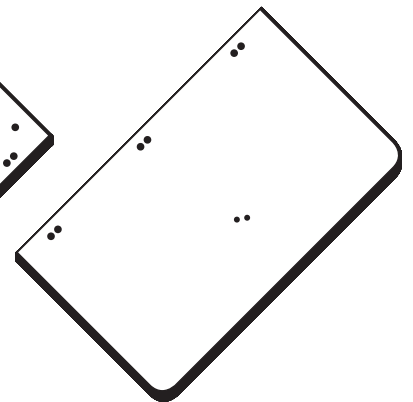
**P. SMALL BOARD**  
11.1" x 31" - 2 pcs.



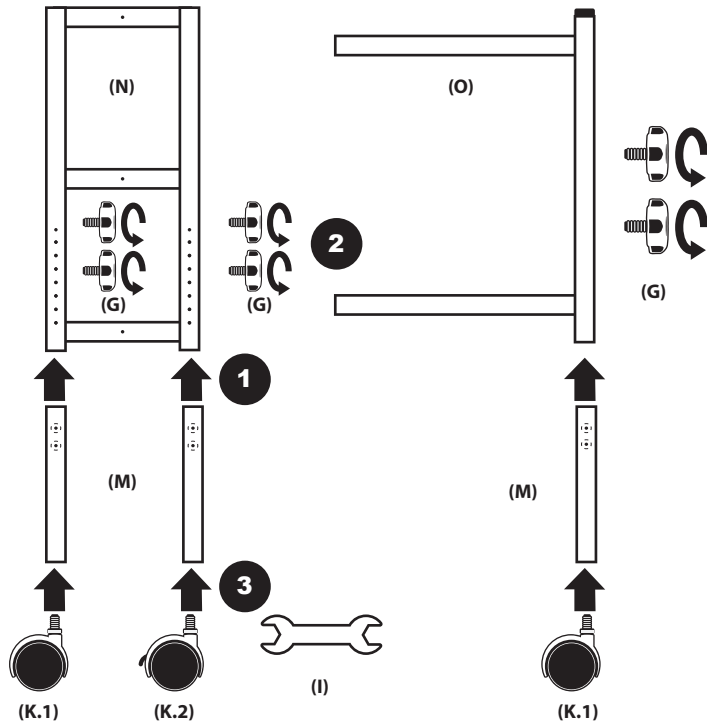
**Q. MEDIUM BOARD**  
15.75" x 36" - 1pc.



**R. LARGE BOARD**  
21.5" x 36" - 2 pcs.



# ADJUSTABLE Home Hobby & Craft Table Instructions



1. Insert all 6 **SHORT BEAMS (M)** into **RECTANGULAR BODY (N)** & **SWING ARMS (O)** .

2. Lock **SHORT BEAMS (M)** into place using **ADJUSTING KNOBS (G)**.

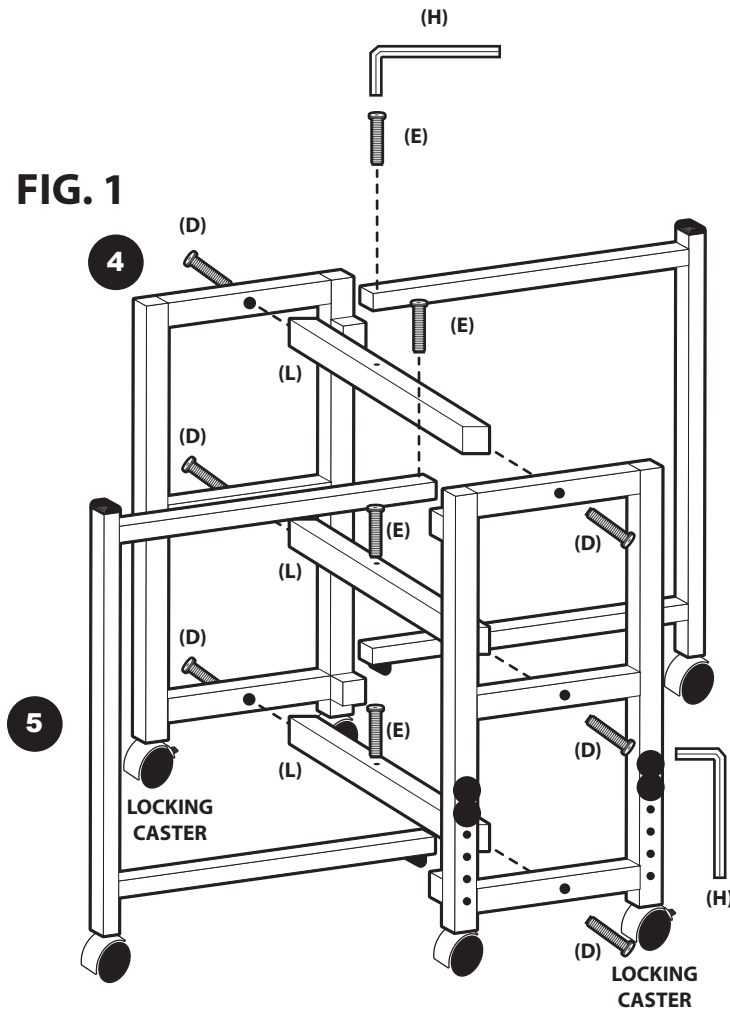
3. Insert 2 **CASTERS (K.1)** into **SWING ARMS (O)** and 2 **CASTERS (K.1)** 1 on each **RECTANGULAR BODY (N)**, use 2 **LOCKING CASTERS (K.2)** one on each **RECTANGULAR BODY (N)** at opposite ends (fig. 1), use **OPEN END WRENCH (I)** to tighten **CASTERS** and **LOCKING CASTERS** in place.

4. Align **RECTANGULAR BODY (N)** one in front of the other, connect them using **LONG BEAMS (L)** with holes facing upward & 6 **HEX-HEAD SCREW (D)** tighten using **ALLEN KEY (H)**.

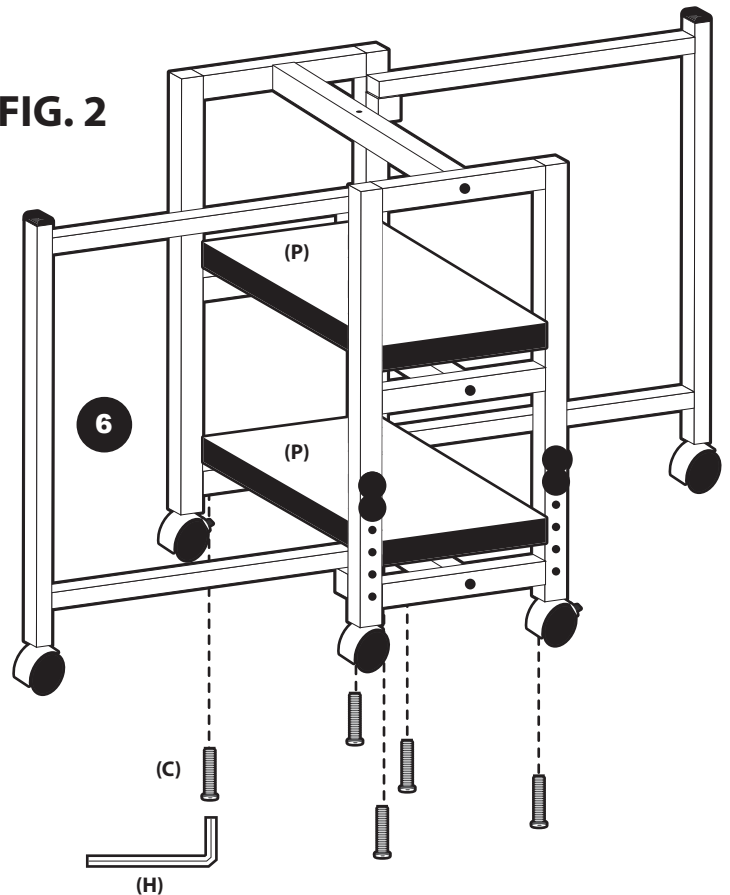
5. Connect **SWING ARMS (O)** to **RECTANGULAR BODY (N)** using 2 **HEX-HEAD SCREW (E)**, tighten with **ALLEN KEY (H)**.

6. Connect **SMALL BOARDS (P)** on bottom tiers of assembly (fig. 2) using **HEX-HEAD SCREWS (C)**, tighten with **ALLEN KEY (H)**.

**FIG. 1**

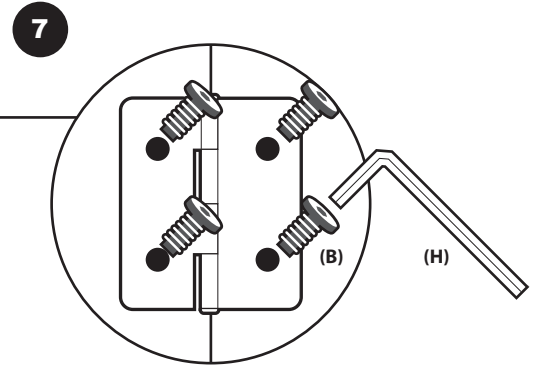
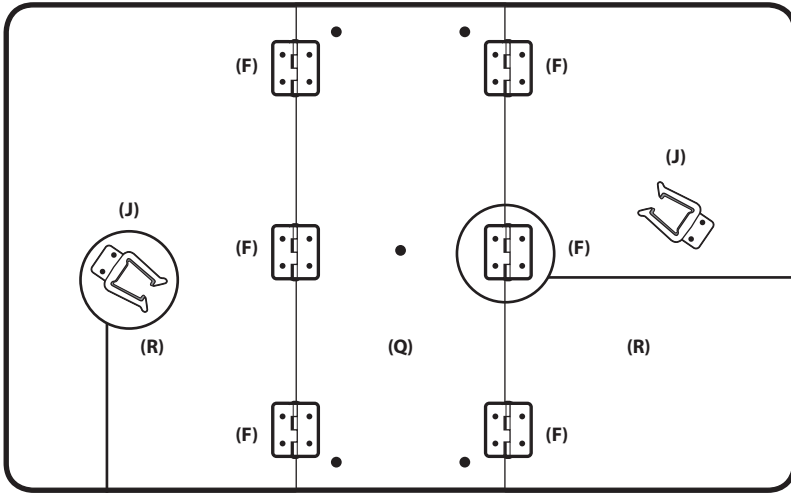


**FIG. 2**

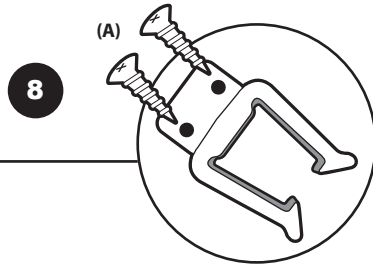


# ADJUSTABLE Home Hobby & Craft Table Instructions

7. Place **LARGE BOARD (R)** and **MEDIUM BOARD (Q)** face down on flat surface, connect them using **HINGES (F)** facing **UP** and **HEX-HEAD SCREWS (B)** tighten using **ALLEN KEY (H)**.

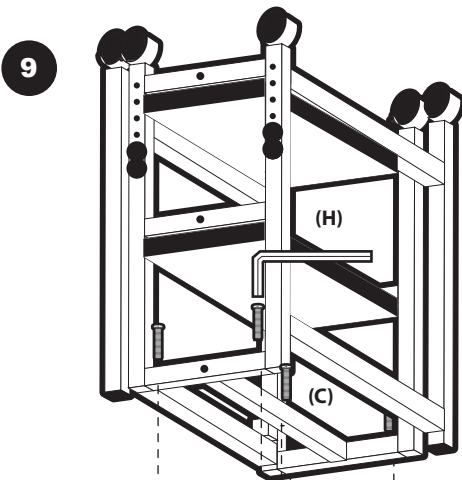


8. Position **STOPS (J)** so that they will connect with **SWING ARMS (O)** when open, use pre-drilled holes and **PHILLIPS HEAD SCREWS (A)**.

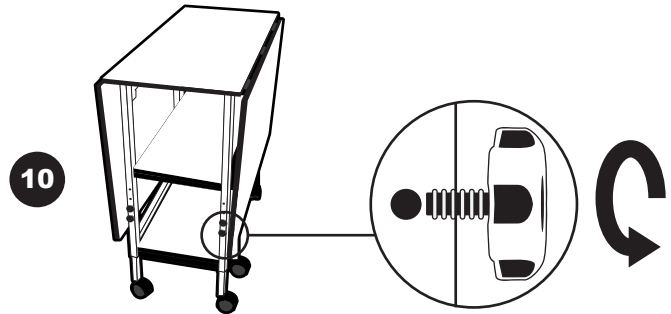


## METAL ASSEMBLY

9. Leave the **BOARD ASSEMBLY** on a sturdy flat surface, close and flip the **METAL ASSEMBLY** and connect using **5 HEX-HEAD SCREWS (C)** tighten using **ALLEN KEY (H)**.



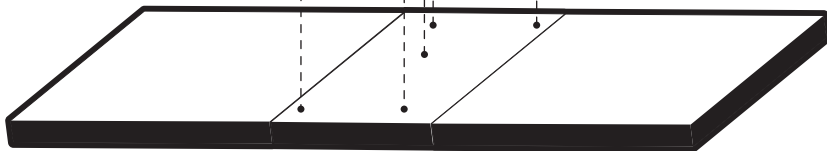
10. Once table is assembled height can be adjusted by folding down the table, then while holding on to **BOARD ASSEMBLY** carefully remove **ADJUSTING KNOBS** one at a time, then place them at desired height.



## SAFETY & MAINTENANCE

This table is not a toy - **DO NOT** let children play on, under, or around it. **DO NOT** place more than 30 pounds on the table wings. To clean table, use a cloth or sponge with mild soap. (**NEVER** use anything abrasive). **NEVER** rest a hot iron directly on the surface.

For ironing, use the Home **Hobby Table Ironing Cover** - in stores everywhere.



## BOARD ASSEMBLY

**PLEASE NOTE:** Our 30-day No Charge replacement policy for parts does not apply to items sold AS IS, CLEARANCE, CLOSEOUT, FINAL SALE, ETC. Any parts requested under these circumstances will be charged to the customer, including shipping charges. Shipping charges for replacement parts to Alaska, Hawaii or any point outside of The Contiguous United States are not covered under our policy.

Sullivans USA, Inc  
4341 Middaugh Ave. Downers Grove, IL 60515 (800) 862-8586 Fax: (630) 435-1532  
M.T. Sullivan & Co. Pty. Ltd.  
40 Parramatta Road Underwood, Brisbane, Queensland Australia  
Sullivans Enterprises (N.Z.) Ltd. 28 Sir William Ave. East Tamaki, Auckland New Zealand  
Sullivans USA, Inc. will replace any missing or defective parts within 30 days or purchase date.  
Fax a dated receipt to (630) 435-1532 along with your request.  
**This policy does not apply to Damages due to shipping.**  
For further assistance, please call (800) 862-8586