

# The Gracie Home Machine Quilting System

## **Contents**

Wood Parts: Box 1 (Queen).....	2
Hardware: Box 2 (Queen) .....	3
Wood Parts: Box 1 (King).....	5
Hardware: Box 2 (King) .....	6
Step 1: Leveling Foot.....	9
Step 2: Frame Ends.....	9
Step 3: Middle Legs.....	10
Step 4: Table-Track Support .....	12
Step 5: Table-Wood Surface .....	13
Step 6: Table-Plastic Track .....	14
Step 7: Rail Brackets .....	14
Step 8: Rails .....	15
Step 9: Rail locations.....	16
Step 10: Carriage .....	18
Fabric Installation.....	19
Making Cloth Leaders .....	20
Installing Fabric Layers To The Rails .....	21
Step 1: Quilt Backing.....	21
Step 2: Quilt Top.....	21
Step 3: Batting.....	21
Step 4: Attaching Layers To Take-Up Rail .....	21
The Four-Inch Principle.....	22
Bungee Clamp Assembly.....	22

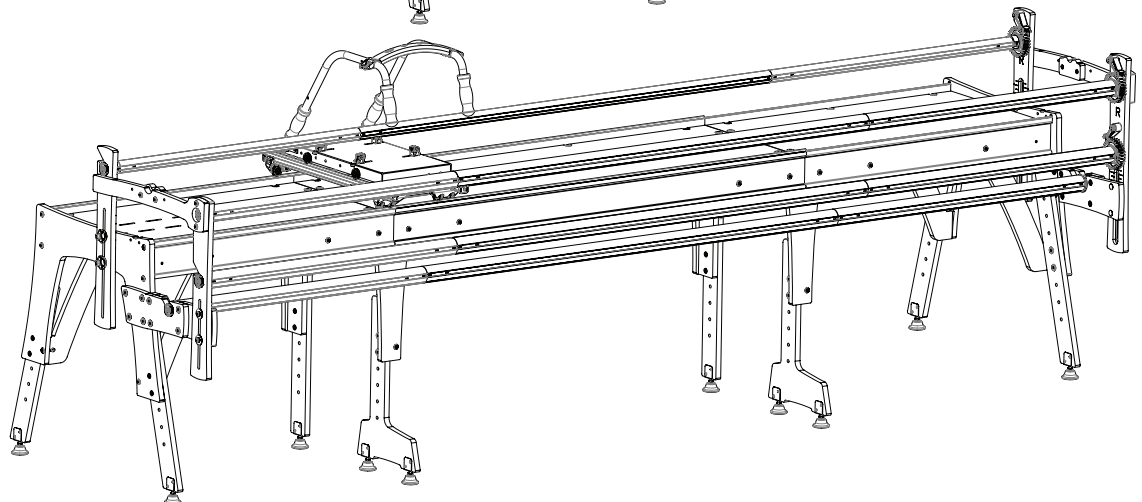
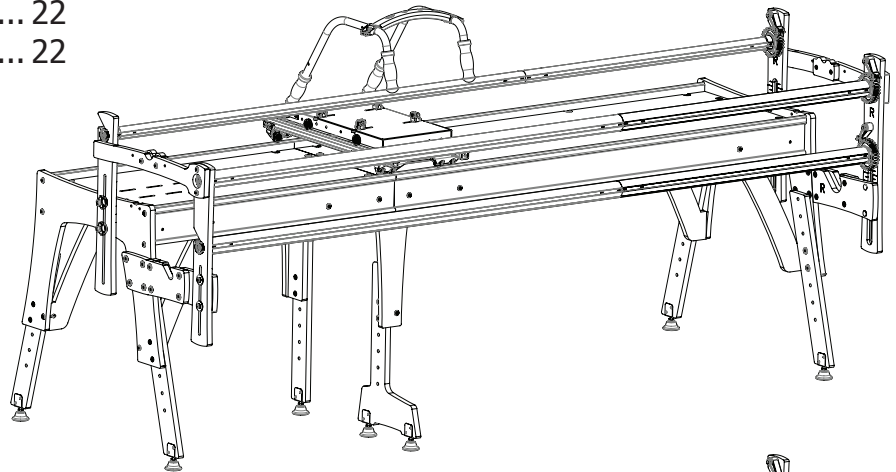
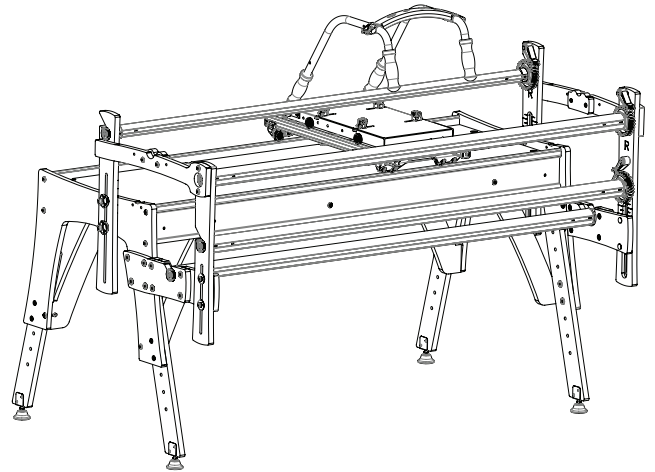

# Wood Parts: Box 1 (Queen)



(1) Middle Leg Top



(1) Arched Middle



(2) Vertical Brace

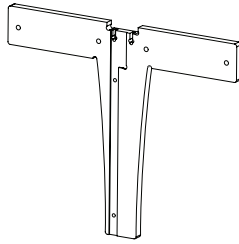

(2) Middle Leg Support



(2) Bungee Rail Holder

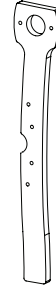

(2) Bungee Arm

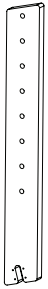

(4) Angled Height Adjustable Leg

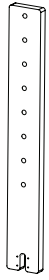

(1) Back Middle Height Adjustable Leg

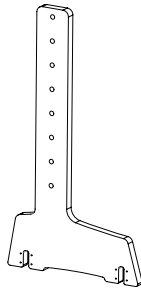

(1) Front Height Adjustable Leg



(2) A Angle Brace



(2) B Angle Brace



(2) Frame End Extension

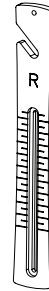

(1) Right Take Up Rail Bracket



(1) Right Fabric Rail Bracket

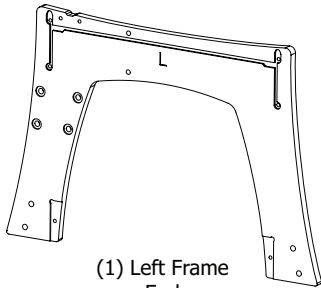

(1) Left Frame End

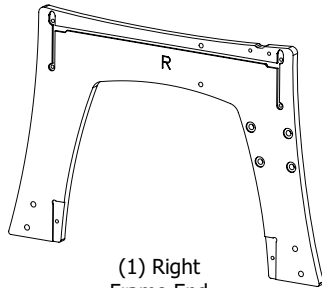

(1) Right Frame End



(1) Left Rail Bracket Extension



(1) Right Rail Bracket Extension

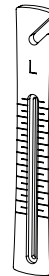

(1) Left Take Up Rail Bracket



(1) Left Fabric Rail Bracket

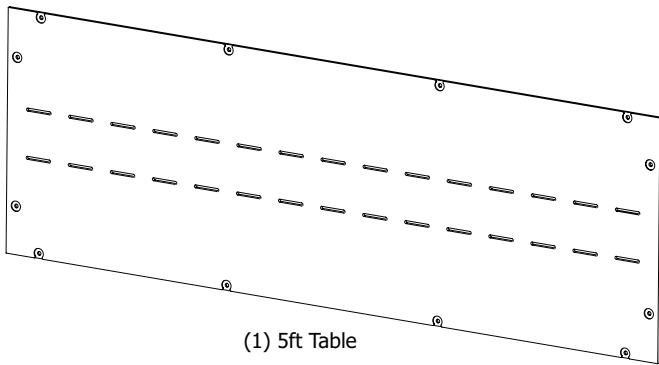

(1) 5ft Table

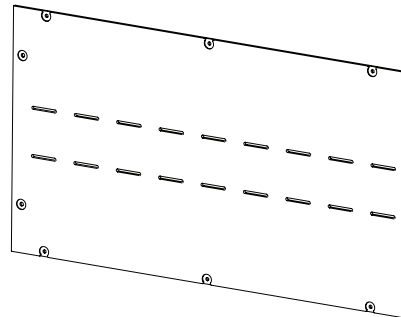

(1) 3ft Table

## Hardware: Box 2 (Queen)

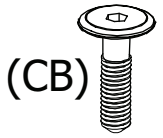

(CB)

(28) M8 x 30mm  
Connector Bolt

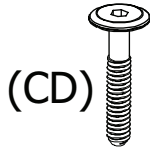

(CD)

(14) M6 x 35mm  
Connector Bolt

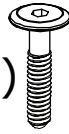

(CE)

(24) M6 x 30mm  
Connector Bolt

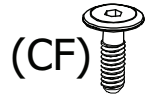

(CF)

(26) M6 x 20mm  
Connector Bolt

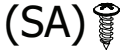

(SA)

(28) M3.5 x 15mm  
Self-Threading Screw

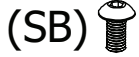

(SB)

(36) M5 x 10mm  
(SBHCS)

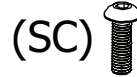

(SC)

(18) M5 x 16mm  
(SBHCS)

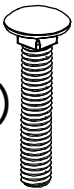

(BA)

(8) M8 x 45mm  
Carriage Bolt

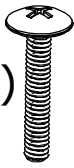

(BB)

(3) M6 x 40mm  
Truss Bolt



(BC)

(6) M4 x 30mm Pan Head  
Self-Threading Screw

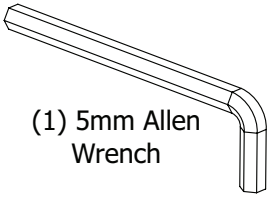

(1) 5mm Allen  
Wrench

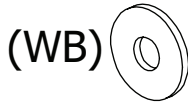

(WB)

(8) M8 Washer  
(8.5 I.D. x 20 O.D. x 1.5mm)



(NA)

(4) M8 Nylock Nut



(NB)

(8) M8 Jam Nut

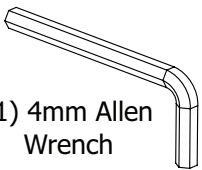

(1) 4mm Allen  
Wrench



(WA)

(8) M8 Washer  
(9 I.D. x 32 O.D. x 2mm)



(NC)

(18) M6 Square Nut



(ND)

(10) M6 Hex Nut

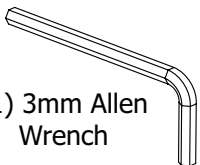

(1) 3mm Allen  
Wrench



(4) Bungee Stop

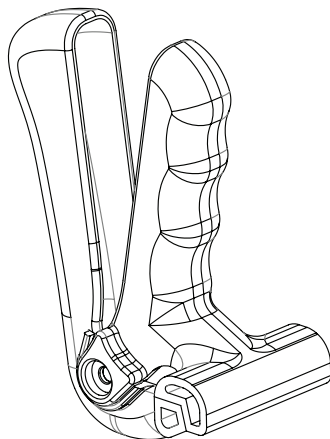

(4) Bungee Clamp

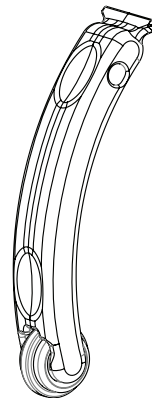

(1) Fabri-Fast Tool

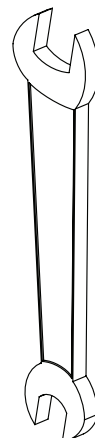

(1) 10mm/13mm Wrench

# Hardware (Continued): Box 2 (Queen)

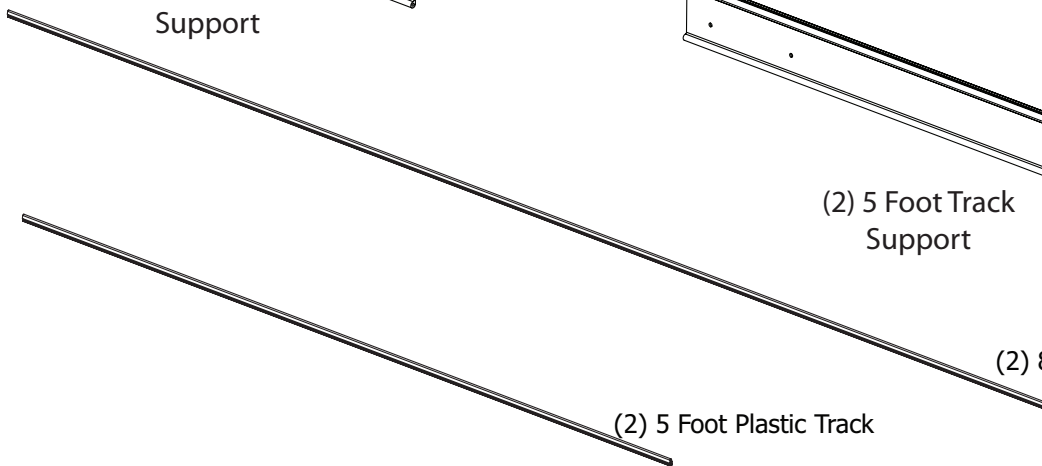
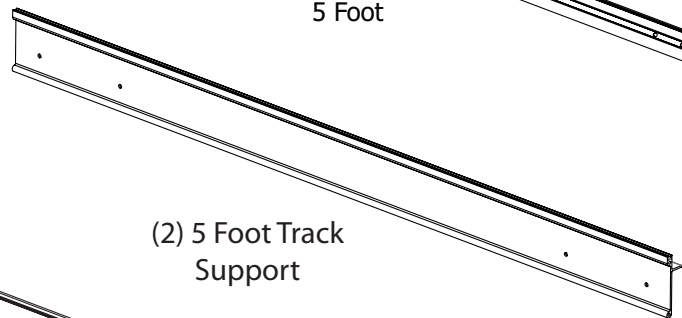
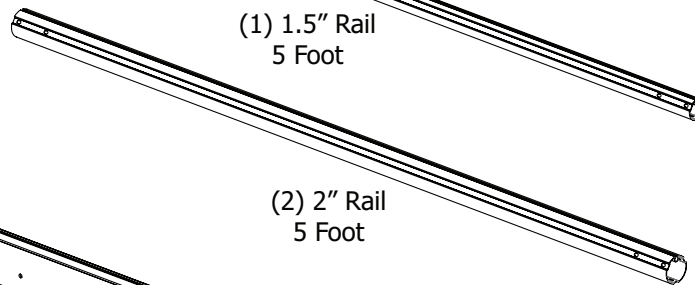
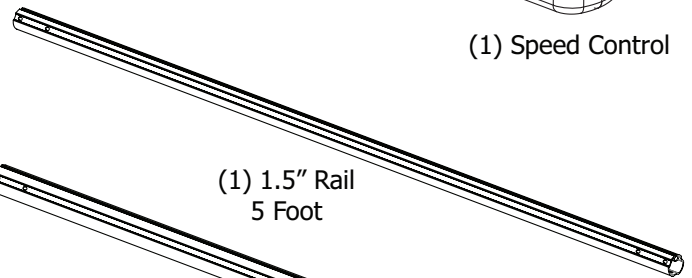
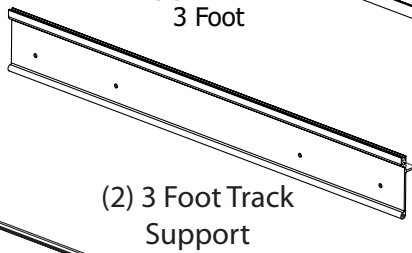
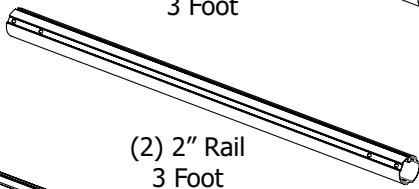
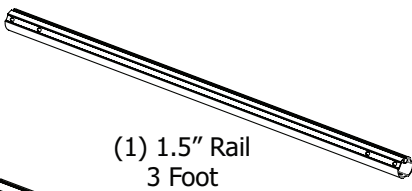
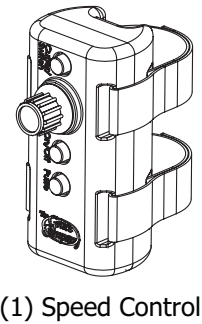
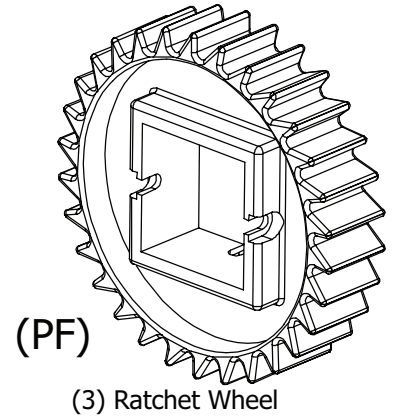
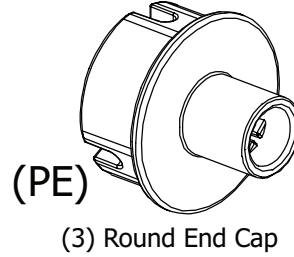
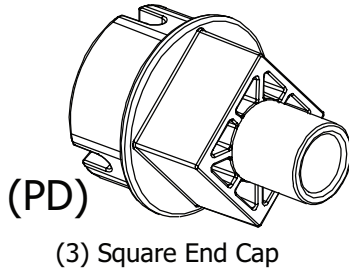
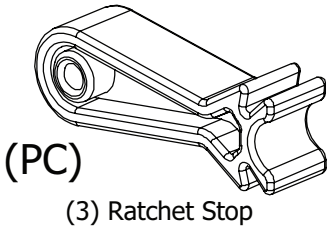
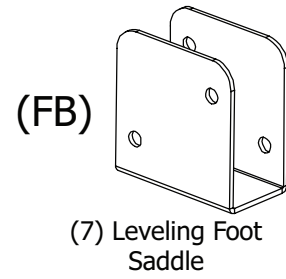
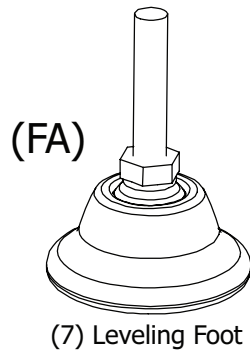
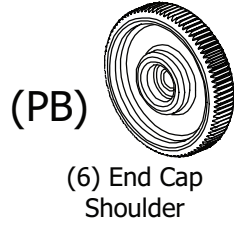
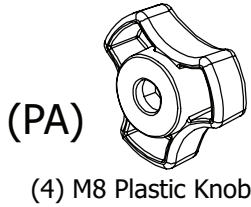

**Wood Parts: Box 1 (King)**



1) Top



(1) Arched  
Middle

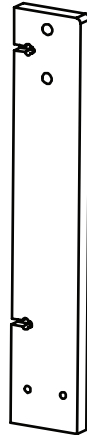

(2) Back  
Vertical  
Brace

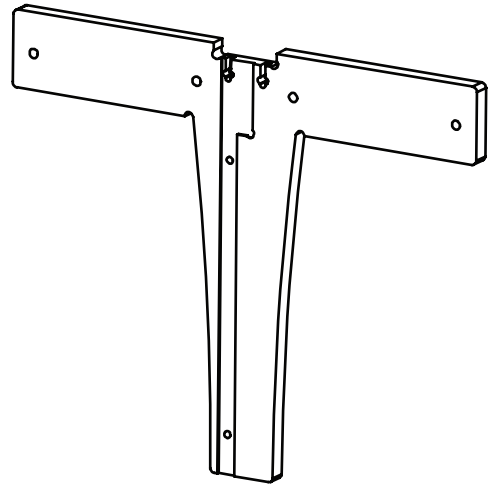

(2) Middle  
Leg Support

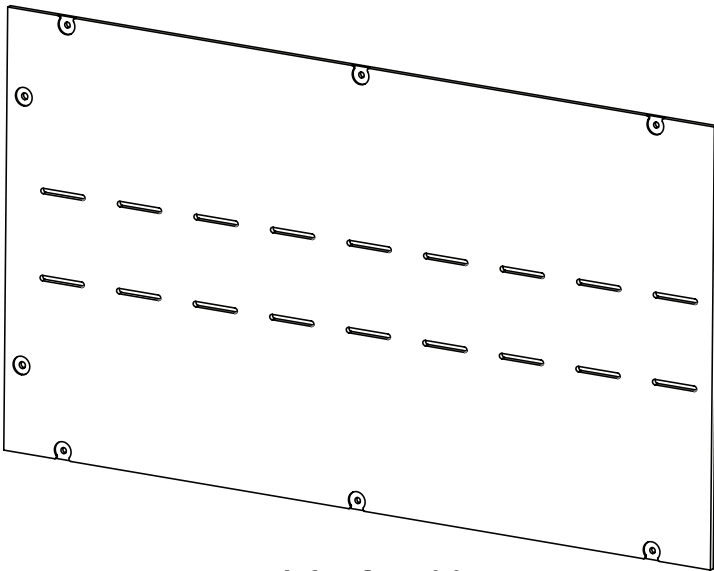

(1) 3ft Table

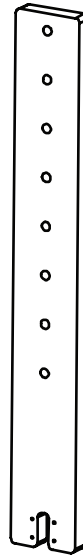

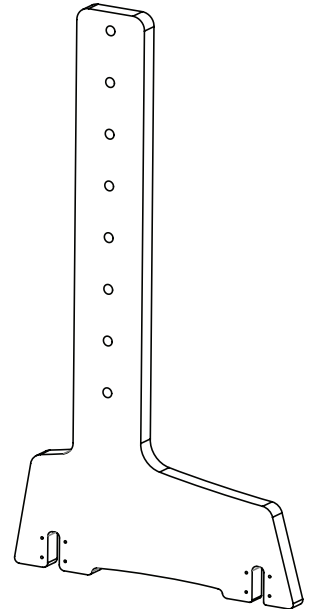

(1) Back Height  
Adjustable Leg



(1) Front Height  
Adjustable Leg

# Hardware: Box 2 (King)

(SA)   
 (12) M3.5 x 15mm  
 Self-Threading screw

(SB)   
 (60) M5 x 10mm  
 (SBHCS)

(SC)   
 (6) M5 x 16mm  
 (SBHCS)

(CF)   
 (14) M6 x 20mm  
 Connector Bolt

(CE)   
 (4) M6 x 30mm  
 Connector Bolt

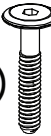
(CD)   
 (10) M6 x 35mm  
 Connector Bolt

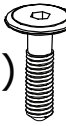
(CB)   
 (4) M8 x 30mm  
 Connector Bolt

(BC)   
 (2) M4 x 30mm Pan Head  
 Self-Threading Screw

(NC)   
 (14) M6 Square Nut

(ND)   
 (2) M6 Jam Nut

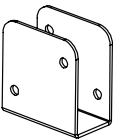
(FB)   
 (3) Leveling Foot  
 Saddle

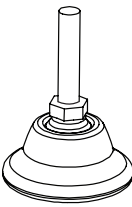
(FA)   
 (3) Leveling Foot

(PB)   
 (2) End Cap  
 Shoulder

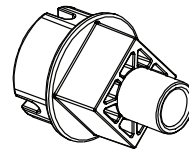
(PD)   
 (1) Square End Cap

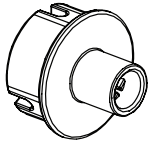
(PE)   
 (1) Round End Cap

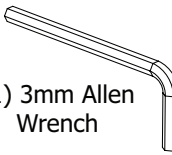
(1) 3mm Allen Wrench 

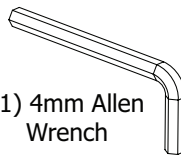
(1) 4mm Allen Wrench 

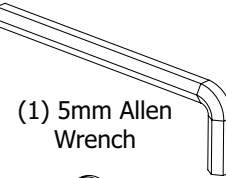
(1) 5mm Allen Wrench 

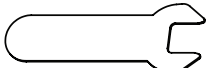
(1) 13mm Wrench 

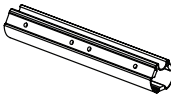
(1) 1.5" Rail Coupler 

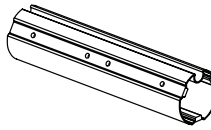
(4) 2" Rail Coupler 

(4) Fabrifast Tubing 

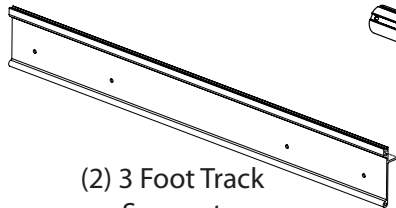
(2) 3 Foot Track Support 

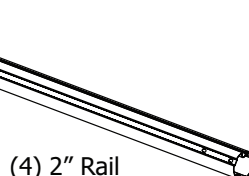
(4) 2" Rail 3 Foot 

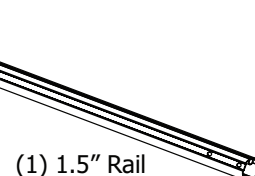
(1) 1.5" Rail 3 Foot 

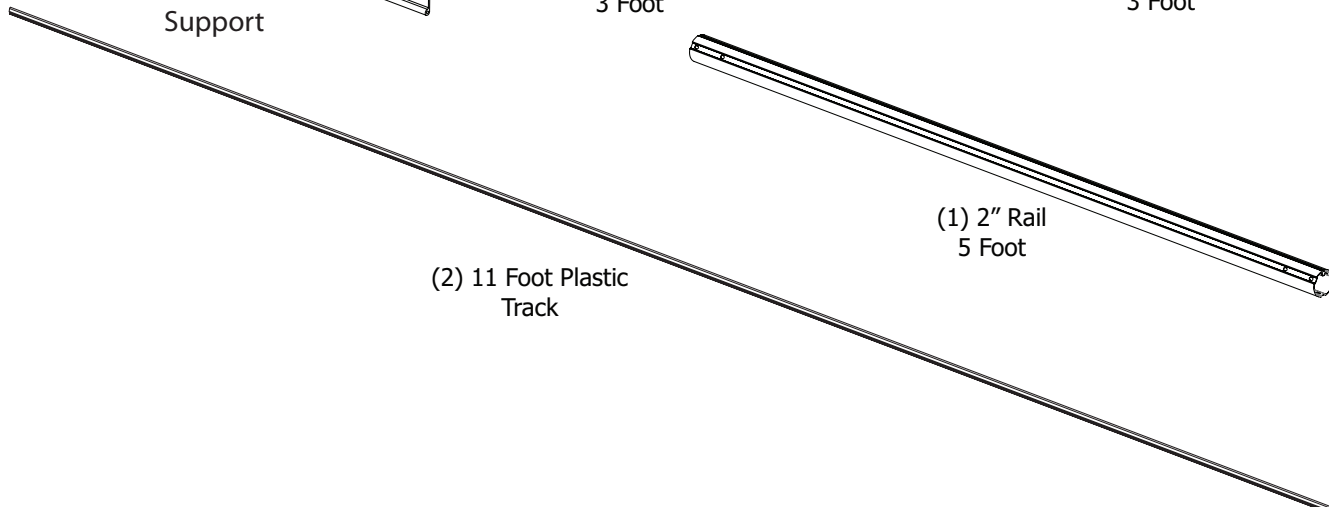
(2) 11 Foot Plastic Track 

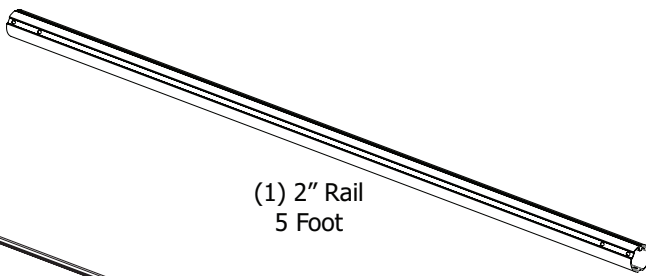
(1) 2" Rail 5 Foot 

## **CARE OF YOUR GRACIE**

The wooden parts on your Gracie frame system can be used finished (Stain, Varnish, etc.), or unfinished. Most people use it unfinished with no problem, and doing so does not adversely affect warranty coverage. However, for extra protection, or to give it a finished look, you may seal, stain and/or finish the frame using a number of different applications. This is best done BEFORE YOU ASSEMBLE your frame.

To seal the wood, we recommend an application of tung oil or Danish Oil finish that will help preserve the wood and will help to prevent warping. Some prefer to use a urethane coat to add a more glossy finish. Test stain on an inconspicuous place. Many different finishes and/or stains may be suitable for sealing and beautifying your frame. You may want to consult your local paint retailer for finishes that are easy to apply and dry hard—not oily.

### **Use and Storage Tip**

--Store frame in a dry place to avoid the possibility of moisture coming into contact with your wood.

### **One-Year Limited Warranty**

GraceWood, Inc. will replace or repair, at our choosing, any part of the Gracie Machine Quilting System which may be shown to be defective. This warranty does not cover parts damaged through misuse, improper storage, improper assembly, loss, natural events and willful or accidental destruction. Defective parts may be returned only with a valid RMA# which may be obtained by calling GraceWood, Inc. at 1-800-264-0644 or 1-801-485-6688.

**NOTE:** Warranty card must be filled out, stamped and mailed to the address on the card within 30 days of purchase.

### **Contact Information**

For Technical Support or any other correspondence concerning your Gracie frame, call 1-800-264-0644 ~

OR ~ E-mail: [support@graceframe.com](mailto:support@graceframe.com) ~ OR ~ Fax: (801) 908-8888 ~

OR ~ Write to:

The Grace Company

P.O. Box 27823

Salt Lake City, UT 84127

For details on accessories and other information, see us online at [www.graceframe.com](http://www.graceframe.com).

For shipping of materials to The Grace Company address package (postage prepaid) to:

The Grace Company

2225 South 3200 West

Salt Lake City, UT 84119

Materials may be returned only with a valid RMA# or Returned Merchandise Authorization Number which may be obtained by calling GraceWood, Inc. at 1-800-264-0644. If you call after business hours (M-F 8:00 a.m. – 5 p.m., MST) be assured that your call will be returned the next business day, if you leave a message.

Please report any errors in these instructions or make comments to the following:

[support@graceframe.com](mailto:support@graceframe.com)

### **Grace Quilting Frames and Hoops: Innovation and Evolution**

Grace Quilting Systems have been developed over the past two decades with several original design innovations. Additionally, because of feedback from many of the thousands of quilters who have purchased and use our machine quilting systems, we have been able to make a frame that will truly enhance the entire process of machine quilting from beginning to end. If you have any suggestions that will help us to improve our product or service, let us know using one of the above contact methods.

## **WELCOME!**

As you begin assembly of your new Gracie home machine quilting system, keep in the mind the following:

- 1)** Plan to spend a minimum of 2-4 hours in assembly. This process will be simple and step-by-step.
- 2)** Read through each step completely before beginning that step.
- 3)** Using the parts list as a reference, take the parts out of the box and make sure that you have them all. (If there is something missing or broken, contact the Grace Company at 1-800-264-0644. Our offices are open from 8:00 am - 5:00 pm MST Mon.-Fri. If calling after hours, you may leave your message and we will promptly ship any item needed).
- 4)** For your convenience, an "L" and "R" have been etched into the INSIDES of many pieces to help you distinguish between left and right parts and inside and outside of parts.
- 5)** Identify Hardware Packets: All hardware is separated by type. Each packet is labeled for ease in identification.
- 6)** This is a new product! We welcome your feedback on this product or these instructions. If you encounter a problem during assembly or use of the Gracie, and you can't seem to overcome it, call us before frustration sets in!

### **Tools Needed:**

10mm Socket Wrench (provided)  
Phillips Screw Driver (Cordless Preferred)  
3mm, 4mm, and 5mm Allen wrenches (provided)  
Fabri-Fast Tool (to be used when installing your fabric)





## Step 1: Leveling Foot

Attach a Leveling Foot to each of the legs included with your frame.

**Note 1:** The Front Height Adjustable Leg requires 2 Leveling Feet.

### Hardware required:

- (SA)   $\text{K}40$  or  $\text{Q}28$  or  $\text{C}16$  M3.5 x 15mm Self-Threading Screw
- (FA)   $\text{K}10$  or  $\text{Q}7$  or  $\text{C}4$  Leveling Foot
- (FB)   $\text{K}10$  or  $\text{Q}7$  or  $\text{C}4$  Leveling Foot Saddle

### Wood Parts required:

- 4 Angled Height Adjustable Leg
- $\text{K}2$  or  $\text{Q}1$  Back Middle Height Adjustable Leg
- $\text{K}2$  or  $\text{Q}1$  Front Height Adjustable Leg

**$\text{K}$ King assembly**  
 **$\text{Q}$ Queen assembly**  
 **$\text{C}$ Crib assembly**

Fig. 1.1

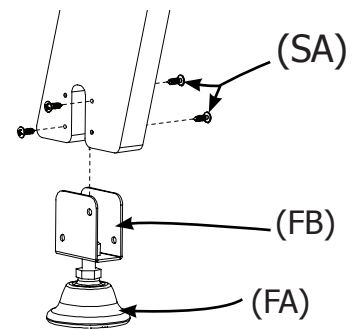







**Step 1.1:** Thread each of the (FA) Leveling Feet into the (FB) Leveling Foot Saddles.

**Step 1.2:** Attach saddle feet to each of the legs, as shown using the (SA) M3.5 x 15mm Self-Threading Screws.

## Step 2: Frame Ends

Perform the outlined steps on the Left and Right Frame Ends to complete the Frame End assemblies.

### Hardware required:

- (CD)  (8) M6 x 30mm Connector Bolt
- (CB)  (24) M8 x 30mm Connector Bolt
- (BA)  (8) M8 x 45mm Carriage Bolt
- (WB)  (8) M8 Washer (8.5 I.D. x 20 O.D. x 1.5mm)
- (NB)  (8) M8 Jam Nut
- (NC)  (4) M6 Square Nut

### Wood parts required:

- 1) Right Frame End
- 1) Right Take-up Rail Bracket
- 1) Right Fabric Rail Bracket
- 1) Left Frame End
- 1) Left Take-Up Rail Bracket
- 1) Left Fabric Rail Bracket
- 2) Bungee Arm
- 2) Bungee Rail Holder
- 1) Right Frame End Extension
- 1) Left Frame End Extension
- 2) Rail Bracket Extension
- 4) Angled Height Adjustable Leg
- 2) A Angle Brace
- 2) B Angle Brace

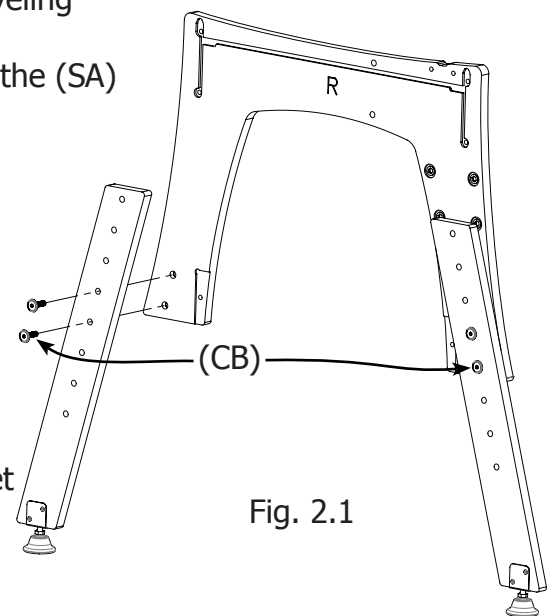

Fig. 2.1

**Step 2.1:** Secure Angled Height Adjustable Legs to the lower backside of each frame end using (CB) M8 x 30mm Connector Bolts as shown in Fig. 2.1

**Step 2.2:** Secure a Frame End Extension to each frame end using (CB) M8 x 30mm Connector Bolts as shown in Fig. 2.2

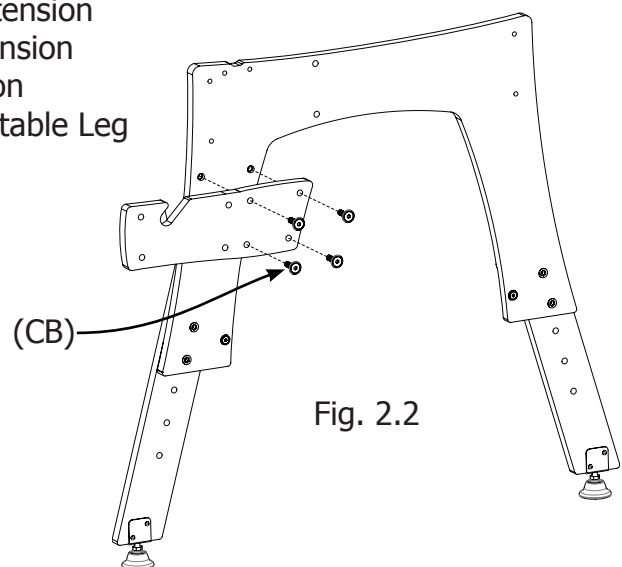

Fig. 2.2

**Step 2.3:** Attach the A and B Angle Braces to the back side of the Frame Ends by using (NC) M6 Square Nuts and (CD) M6 x 35mm Connector Bolts.

**Note 2.3.1:** The "T" Slots in the braces should always face in.

**Note 2.3.2:** You may need to re-adjust the Angled Height Adjustable Legs to get the braces positioned correctly.

**Step 2.4.1:** Secure a Rail Bracket Extension to each Frame End Extension using (CB) M8 x 30mm Connector Bolts as shown in Fig. 2.4

**Note 2.4:** An "L" and "R" have been engraved onto the Rail Bracket Extensions, to indicate which frame end they are to be attached.

**Step 2.5.1:** Insert (BA) M8 x 45mm Carriage Bolts through the 4 holes indicated (in Fig. 2.4), in each Frame End.

**Step 2.5.2:** Place a (WB) M8 Washer (8.5 ID x 20 OD x 1.5mm), followed by a (NB) M8 Jam Nut onto the exposed end of each Carriage Bolt. Tighten the Jam Nuts until the bolts square shoulders are pulled completely into the wood.

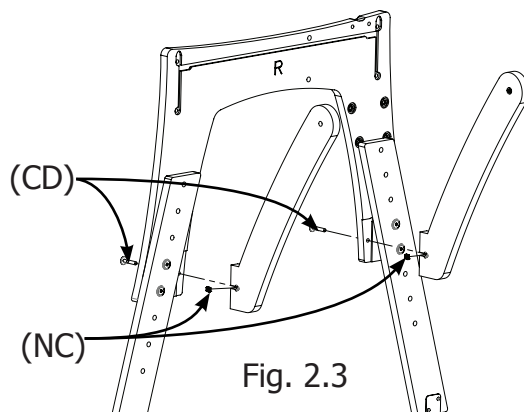

Fig. 2.3

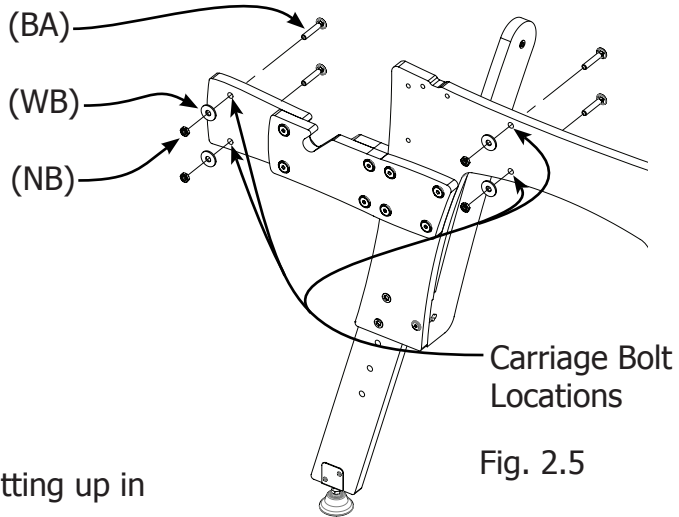
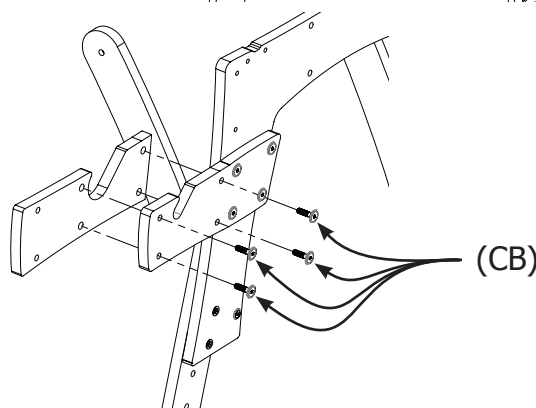





Fig. 2.5

**Step 3: Middle Legs**

**Note:** Skip this step when setting up in crib size.

**Materials required:**

**Hardware required:**

- (CD)   $\text{K}20$  or  $\text{Q}10$  M6 x 35mm Connector Bolt
- (CE)   $\text{K}8$  or  $\text{Q}4$  M6 x 30mm Connector Bolt
- (CB)   $\text{K}8$  or  $\text{Q}4$  M8 x 30mm Connector Bolt
- (NC)   $\text{K}20$  or  $\text{Q}10$  M6 Square Nut

$\text{K}$ King assembly  
 $\text{Q}$ Queen assembly

**Wood Parts:**

- $\text{K}2$  or  $\text{Q}1$  Middle Leg Top
- $\text{K}2$  or  $\text{Q}1$  Arched Middle
- $\text{K}4$  or  $\text{Q}2$  Vertical Braces
- $\text{K}4$  or  $\text{Q}2$  Middle Leg Supports

**Note:** If you are assembling the King size frame complete this step 2 times.

**Step 3.1:** Secure the Middle Leg Top to the Arched Middle using (CD) M6 x 35mm Connector Bolts, and (NC) M6 Square Nuts .

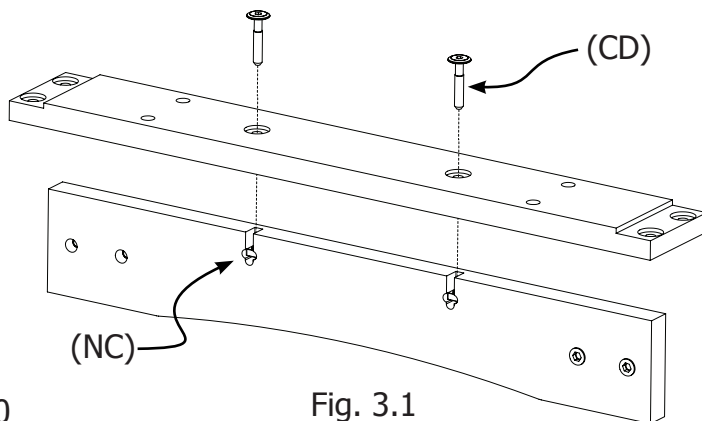
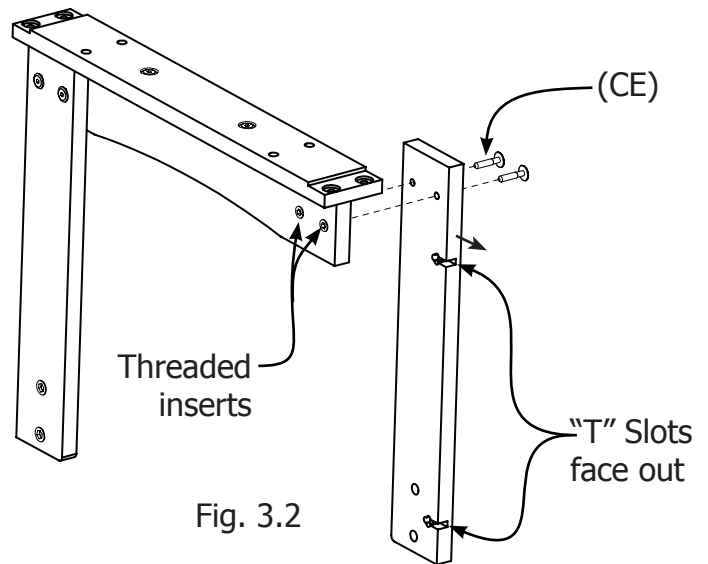

Fig. 3.1

**Step 3.2:** Attach the Vertical Braces to the Arched Middle using (CE) M6 x 30mm Connector Bolts.

**Note 3.2.1:** Make sure that the threaded inserts are on the back side of the Arched Middle, in relation to the Vertical Brace you are attaching.

**Note 3.2.2:** Make sure that the "T" slots on the vertical braces face out.



**Step 3.3:** Insert (NC) M6 Square Nuts into the "T" slots located in the Vertical Braces (2 ea.), as well as those located in the Middle Leg Supports (2 ea.).

**Step 3.4:** Secure the Middle Leg Supports to the Vertical Braces using (CD) M6 x 35mm Connector Bolts.

**Step 3.5:** Secure the Middle Leg Supports to the Middle Leg Top using (CD) M6 x 35mm Connector Bolts.

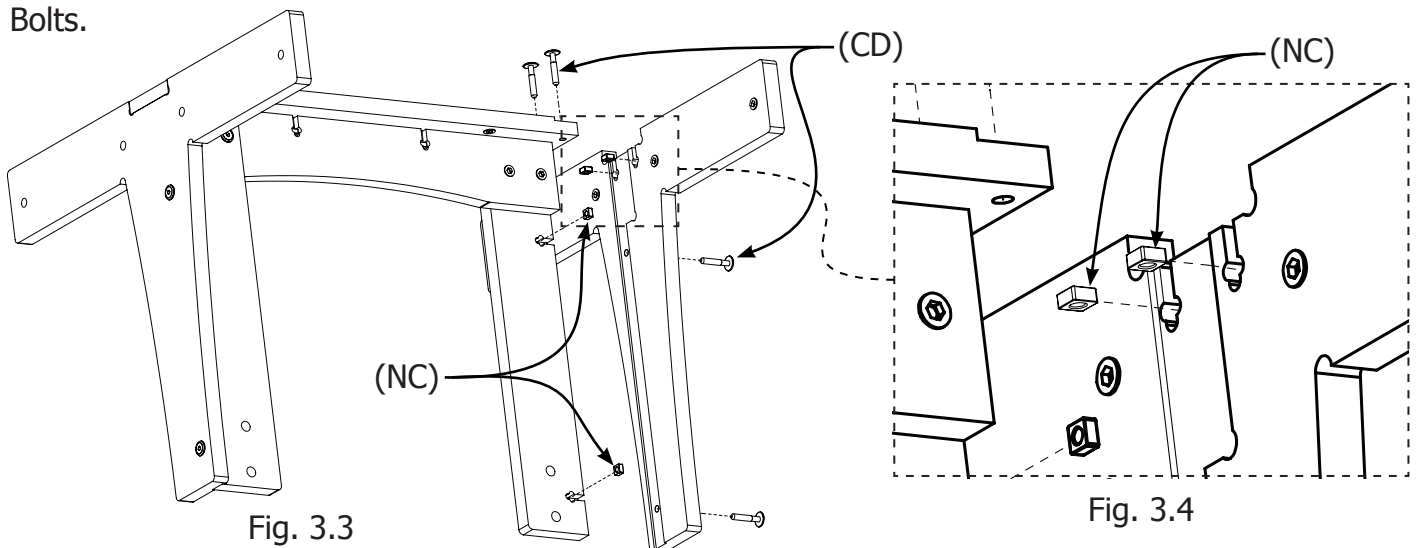

**Step 3.6:** Finally, attach the Front and Back Middle Legs to the lower holes in the Vertical Braces using (CB) M8 x 30mm Connector Bolts.

**Note 3.6:** Attach the adjustable legs to the inside of the Vertical Braces. This should be the side of the Vertical Brace opposite of the side with the threaded inserts.

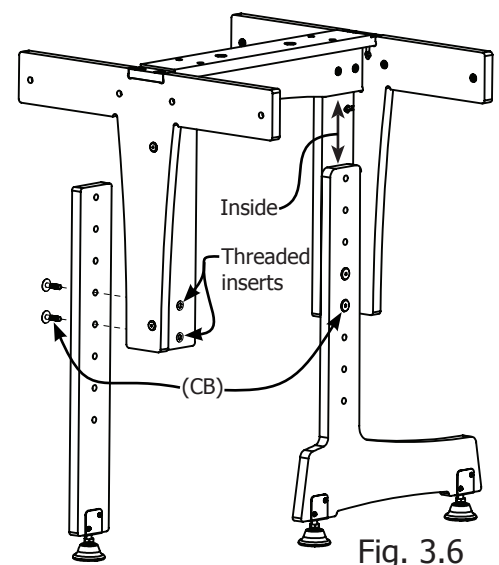

**Note 3.King:** If you are building the King size version of the frame, you will need to build an additional pair of middle legs. These parts are located in the King boxes.



## Step 4: Table-Track Support

**Note:** For Crib only do steps 4.1.1 through step 4.2

### Materials required:

- (CE)   $\text{K}^{16}$  or  $\text{Q}^8$  or  $\text{C}^4$  M6 x 30mm Connector Bolt
- (CF)   $\text{K}^{24}$  or  $\text{Q}^{12}$  or  $\text{C}^4$  M6 x 20mm Connector Bolt

$\text{K}$  King assembly  
 $\text{Q}$  Queen assembly  
 $\text{C}$  Crib assembly

- $\text{K}^4$  or  $\text{Q}^2$  3ft. Aluminum Track Support  
 2 5ft. Aluminum Track Support

- 1 Left Frame End Assembly  
 1 Right Frame End Assembly  
 $\text{K}^2$  or  $\text{Q}^1$  Middle Leg Assembly

**Step 4.1.1:** Attach the 3 foot Aluminum Track Supports to the Left Frame End Assembly as shown (for Crib use the 5 Foot Aluminum Track Support).

**Step 4.1.2:** Use (CE) M6 x 30mm Connector Bolts to fasten the Track Support to the frame end.

**Step 4.1.3:** Use (CF) M6 x 20mm Connector Bolts to fasten the Track Supports to the Angle Braces.

**Step 4.2:** Attach the 5 foot Aluminum Track Supports to the Right Frame End Assembly as done in step 4.1 (**For the King setup use 3 Foot Aluminum Track Supports for this step.**)

**Step 4.3.1:** Secure the Middle Legs to the ends of the previously attached Aluminum Track Supports, for both the Left, and Right Frame Ends.

**Step 4.3.2:** Use (CF) M6 x 20mm Connector Bolts to fasten the Track Supports to the Middle Legs.

**Note:** Align the edges of the Aluminum Track Supports before completely tightening the bolts into the Middle Legs.

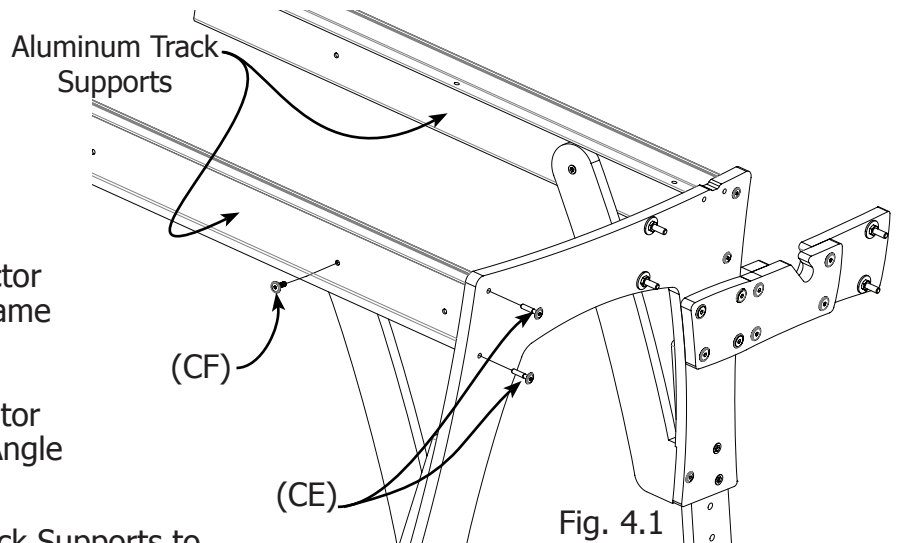

Fig. 4.1

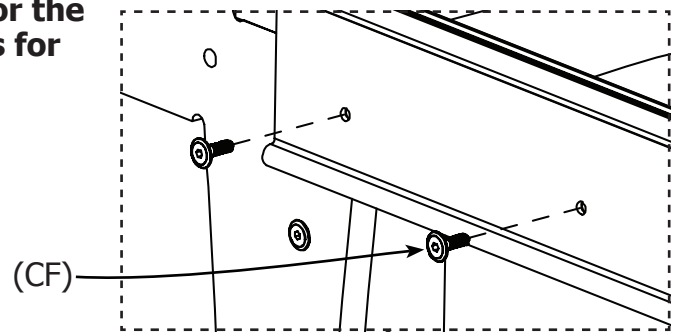

Fig. 4.3.1

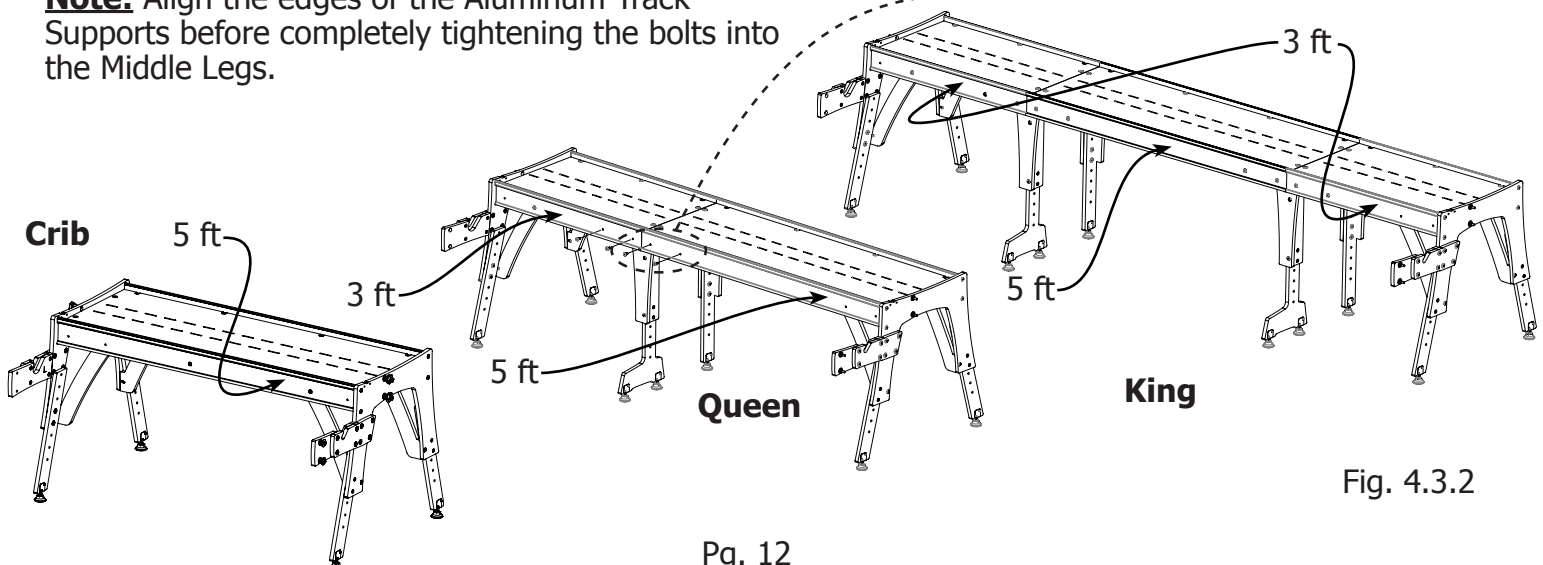



Fig. 4.3.2

## **Step 5: Table-Wood Surface**

### **Hardware required:**

- (CF)  K20 or Q14 or C8 M6 x 20mm  
Connector Bolt
- (ND)  K20 or Q14 or C8  
M6 Hex Jam Nut

### **Wood Parts required:**

- K2 or Q1 3ft Table  
1 5ft Table

K King assembly only  
Q Queen assembly only  
C Crib assembly only

**Note:** For Crib Assembly only do steps 5.2 through step 5.4

**Step 5.1:** Place the 3 Foot Table Surface onto the frame over the 3 Foot Track Supports.

**Note 5.1:** There are holes in only one end of the 3 Foot Table. Make sure that these holes are placed over the middle legs. **(This rule applies to the King setup also.)**

**Step 5.2:** Place the 5 Foot Table onto the frame over the 5 foot track supports.

**Step 5.3.1:** Secure the Table surfaces to the frame by first inserting the (CF) M6 x 20mm Connector Bolt through each of the available locations.

**Note 5.3.2:** There are some holes in the tables that will not be used, they are provided for alternate frame configurations.

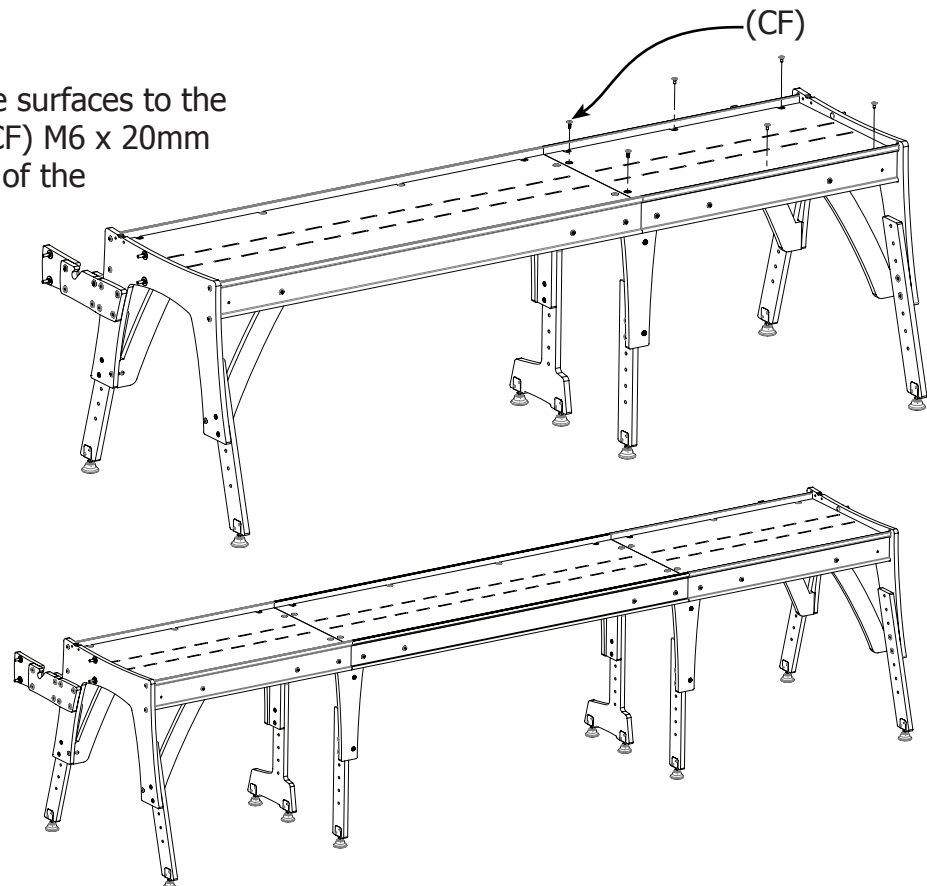
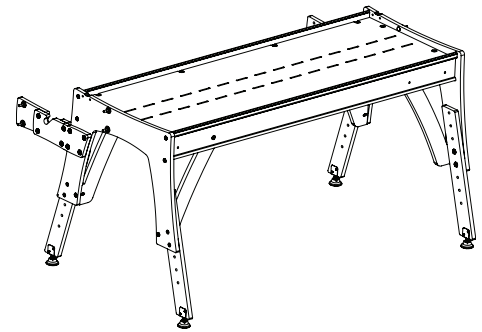

**Note 5.3.3:** If the holes in the table don't line up with the holes in the Aluminum Track Supports the frame may be slightly out of square. This can be corrected by pushing/pulling the front of the frame one direction, while pushing/pulling the back of the frame the opposite direction, until the holes in the table line up.

**Step 5.4:** Place (ND) M6 Hex Nuts onto the end of the bolts which pass through the Aluminum Track Supports. Hold the Hex Nuts in place using the provided Wrench while tightening the bolts completely using the 4mm Allen Wrench.

## **Step 6: Table-Plastic Track**

### **Materials required**

#### **Crib**

(2) 5ft Plastic track

#### **Queen**

(2) 8ft Plastic track

#### **King**

(2) 11ft Plastic track

Fully inserted track

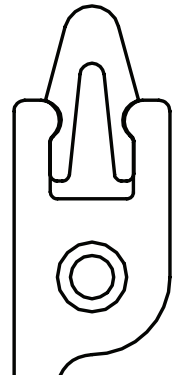



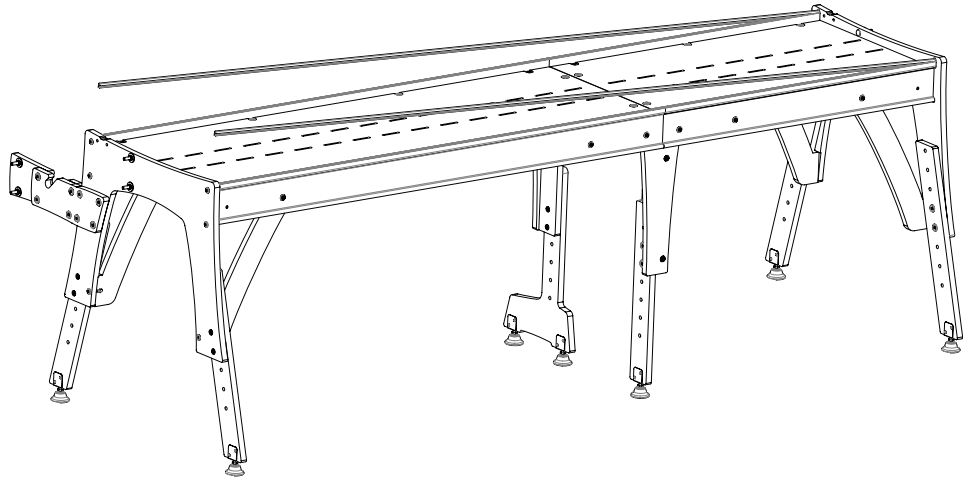

**Step 6.1:** Insert the Plastic Track by firmly pressing one end of the track into the Aluminum Track Support. Work your way down the track until each piece has been completely pressed into the track supports.



## **Step 7: Rail Brackets**

### **Hardware required:**

- (PA)  (4) M8 Plastic Knob
- (WA)  (8) M8 Washer  
(9 I.D. x 32 O.D. x 2mm)
- (NA)  (4) M8 Nylock Nut
- (CE)  (8) M6 x 30mm Connector Bolt

### **Wood Parts Required**

- 1) Right Take-Up Rail Bracket
- 1) Left Take-Up Rail Bracket
- 1) Right Fabric Rail Bracket
- 1) Left Fabric Rail Bracket

**Step 7:** Place the Rail Brackets onto the frame ends as shown.

**Step 7.1:** Secure the Rail Brackets to each end of the frame by first placing a (WA) M8 Washer (9 ID x 32 OD x 2mm) onto the exposed ends of the Carriage Bolts. Next, fasten a (PA) Plastic knob onto the bolts in the Take-Up Rail Brackets. Put a (NA) M8 Nylock Nut onto the bolts in the Fabric Rail Brackets.

**Note 7.1.1:** You will adjust the Fabric Rail Brackets permanent location later on.

The Take-Up Rail Brackets need to be adjusted frequently while quilting to accommodate for the increasing diameter, as the finished quilt sections are rolled onto the Take-Up Rail.

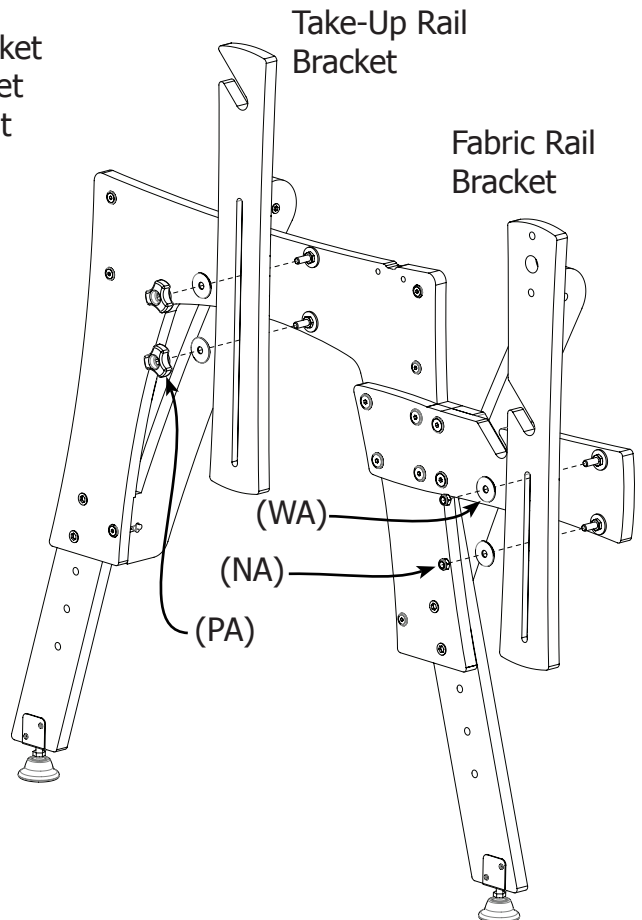

**Step 7.2:** Attach a Bungee Rail Holder to each of the Bungee Arms using (CE) M6 x 30mm Connector Bolts.

**Note 7.2:** Make sure to have the threaded insert (in the rail holder) facing away from the Bungee Arm. Also, make left and right pairs of the Bungee Arms, as shown in Fig 7.2

**Step 7.3:** Bolt the Bungee Arms to each of the Fabric Rail Brackets using (CE) M6 x 30mm Connector Bolts, as shown in Fig. 7.3

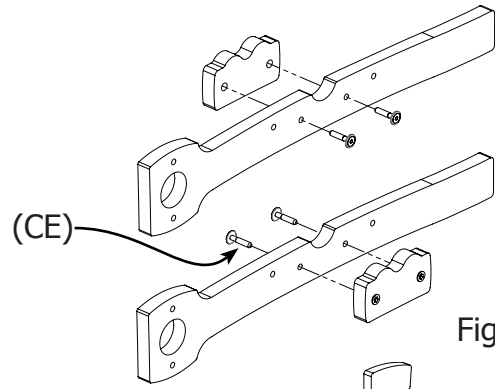

Fig. 7.2

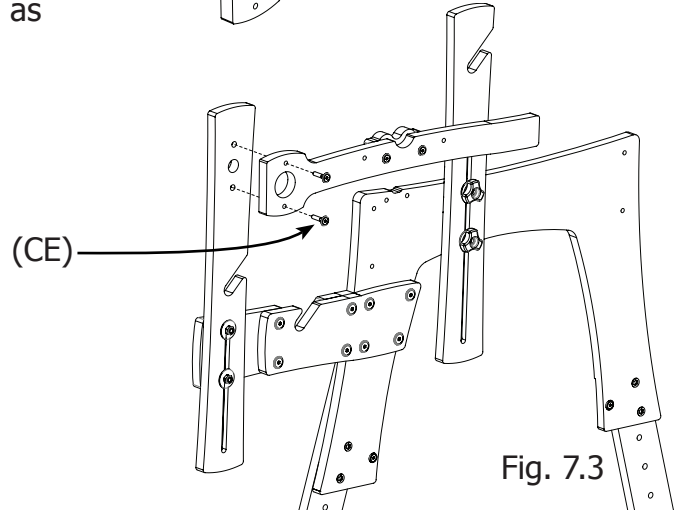





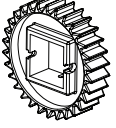

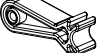

Fig. 7.3

**Step 8: Rails**

**Hardware**

- (SC)   $\text{K}24$  or  $\text{Q}18$  M5 x 15mm (SBHCS)
- (SB)   $\text{K}96$  or  $\text{Q}36$  M5 x 10mm (SBHCS) (not in crib)
- (BB)  3 M6 x 40mm Truss Bolt
- (BC)   $\text{K}8$  or  $\text{Q}6$  M4 x 30mm Pan Head Self-Threading Screw
- (PD)   $\text{K}4$  or  $\text{Q}3$  Square End Cap
- (PE)   $\text{K}4$  or  $\text{Q}3$  Round End Cap
- (PF)  3 Ratchet Wheel
- (PB)   $\text{K}8$  or  $\text{Q}6$  End Cap Shoulder
- (PC)  3 Ratchet Stop

**Rails**

- ( $\text{K}2$  or  $\text{Q}1$ ) 1.5" Rail Coupler (not in Crib)
- ( $\text{K}2$  or  $\text{Q}1$ ) 1.5" x 3 ft. Aluminum Rail
- (1) 1.5" x 5 ft. Aluminum Rail
- ( $\text{K}6$  or  $\text{Q}2$ ) 2" Rail Coupler (not in Crib)
- ( $\text{K}6$  or  $\text{Q}2$ ) 2" x 3 ft. Aluminum Rail
- ( $\text{K}3$  or  $\text{Q}2$ ) 2" x 5 ft. Aluminum Rail

$\text{K}$ King assembly  
 $\text{Q}$ Queen assembly

Crib rail = (1) 5 ft = 5 ft (only end caps required, details at Step 8.5)

Queen rail = (1) 3 ft + (1) 5 ft = 8 ft

King rail = (1) 3 ft + (1) 5 ft + (1) 3 ft = 11 ft

**Step 8.1:** Build the Take-Up Rail (1.5" Diameter, smaller) by first inserting a 1.5" Rail Coupler halfway into one end of the 1.5" x 5 Foot Rail. (**For King size:** attach a Rail coupler into both ends of the 5 foot rail section.)

**Note 8.1:** Center the holes in the Coupler with the slotted holes in the rails.

**Step 8.2:** Fasten the Coupler to the Rail using (SB) M5 x 10mm (SBHCS).

**Note 8.2:** To ensure proper hole alignment, partially thread each of the 6 required screws into each half of the Coupler before completely tightening.

**Step 8.3:** Place a 1.5" x 3 Foot Rail onto the exposed end of each of the Rail Couplers, and secure into place as done in step 8-2.

**Note 8.3:** Remember to partially thread each of the 6 screws in before completely tightening any of them.

**Step 8.4:** Repeat steps 8.1 to 8.3 using the remaining rails, and couplers (2" Diameter, larger) to build 2 more rails for queen, 3 rails if building King.

**Step 8.5:** Completely press the Round End Caps onto the end of each of your 5 foot rail sections. (With **King size**, you may put the end cap onto either rail end.)

**Step 8.6:** Completely press the Square End Caps onto the opposite end of the rails.

**Note 8.6:** The end caps work on both the 1.5", and the 2" rails.

**Step 8.7:** Secure the end caps to the rails using (SC) M5 x 16mm (SBHCS)

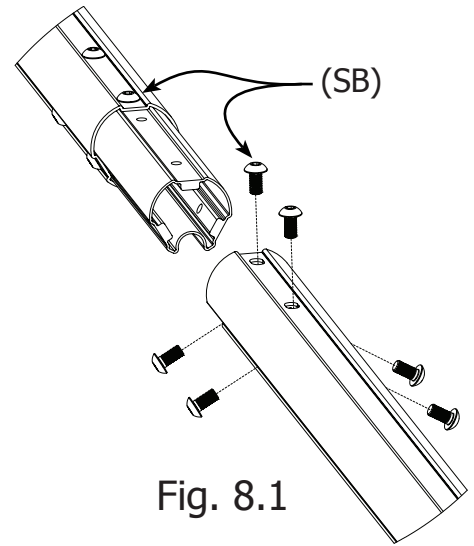

Fig. 8.1

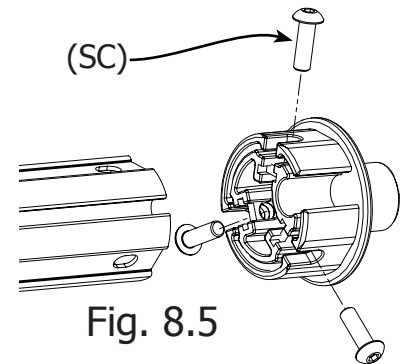

Fig. 8.5

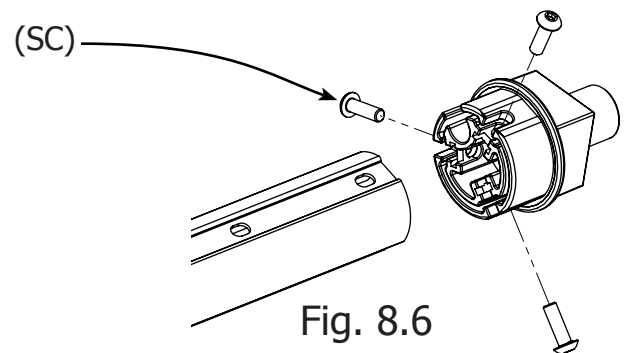

Fig. 8.6

**Step 9: Rail locations**

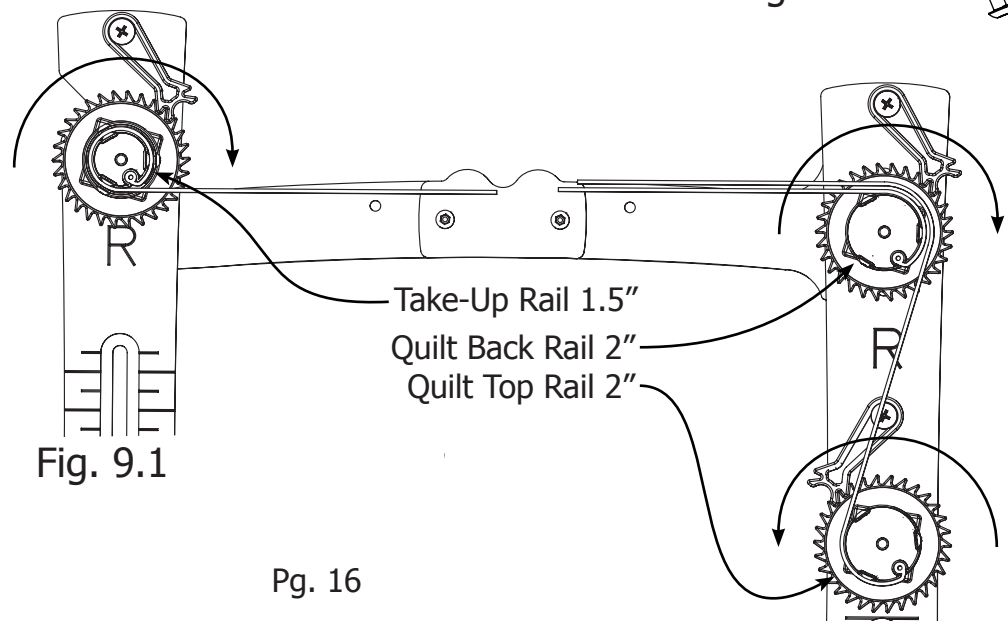

Fig. 9.1



**Step 9.1: (Quilt Back - 2 inch Rail)** Place a Ratchet Wheel onto the Square End Cap located on the end of one of the 2" rails. Make sure to have the ratchet wheel arranged as shown in Fig. 9.1 (Quilt Back). This rail will ratchet clockwise when adjusting fabric tension.

**Step 9.2:** Insert the Square End Cap into the top hole in the Right Fabric Rail Bracket.

**Step 9.3:** To get the Rail into the Left Fabric Rail Bracket, pull the Rail Bracket away from the Rail. When there is a large enough opening slide the Round End Cap into the top hole in the Left Rail Bracket.

**Step 9.4: (Quilt Top - 2 inch Rail)** Place a Ratchet Wheel onto the Square End Cap on a 2" Rail. Make sure to have the Ratchet Wheel arranged as shown in Fig. 9.1 (Quilt top). This Rail will ratchet counter-clockwise.

**Step 9.5:** Insert the end of the Rail with the Square End Cap into the slot in the Right Fabric Rail Bracket. Simultaneously insert the end of the rail with the Round End Cap into the slot in the Left Fabric Rail Bracket.

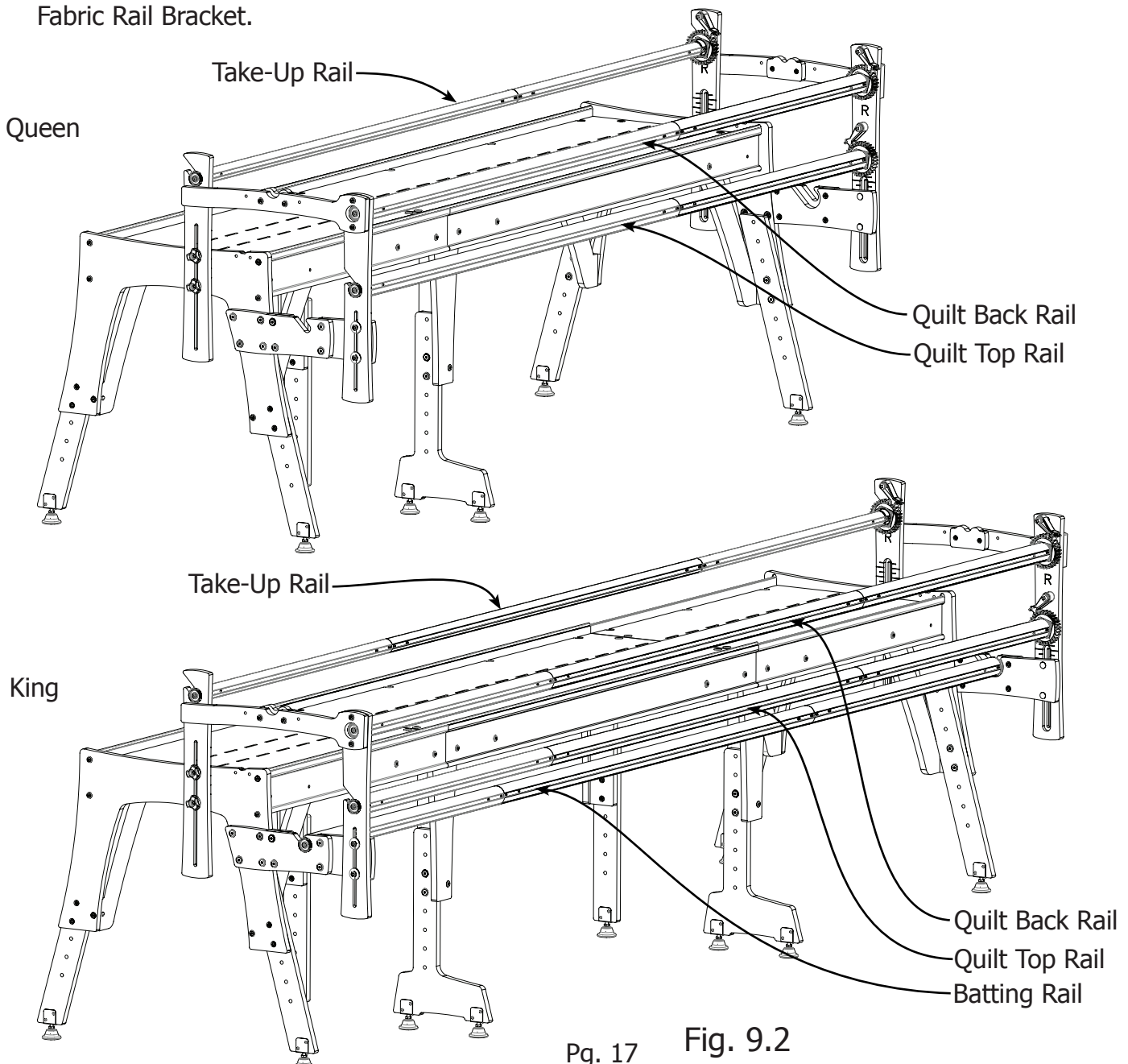

**Step 9.6: (Batting rail - 2 inch Rail)** (Optional, provided with King only) Insert the Square End Cap into the slot in the Right Frame End Extension. Insert the Round End Cap into the slot in the Left Frame End Extension.

**Complete the remaining portion of this step after building the carriage (Step 10).**

**Step 9.7: (Take-Up Rail)** Place the remaining Ratchet Wheel onto the Square End Cap on the 1.5" Rail. Make sure to have the Ratchet Wheel arranged as shown in Fig. 9.1 (Take-Up Rail). This Rail will ratchet clockwise.

**Step 9.8:** After passing one end of the rail through the throat of your sewing machine, insert the end of the rail with the Square End Cap into the slot in the Right Take-Up Rail Bracket. Simultaneously insert the end of the Tail with the Round End Cap into the slot in the Left Take-Up Rail Bracket.

**Step 9.9:** Attach a Shoulder End Cap onto each end of each Rail using (BC) M4 x 30mm Self-threading Screws. Figs. 9.9.1, & 9.9.2

**Note 9.9:** Be careful to not ever tighten the screws that hold on the Shoulder End Caps. As you tighten the screws, watch the gap indicated in Fig. 9.9.3. The gap is required to allow the rails to roll freely.

**Step 9.10:** Attach Ratchet Stops to the Right End Rail Brackets using (BB) M6 x 40mm Truss Bolts, as shown in fig. 9.10, also use Fig. 9.1 as a reference. (Finger tighten only)

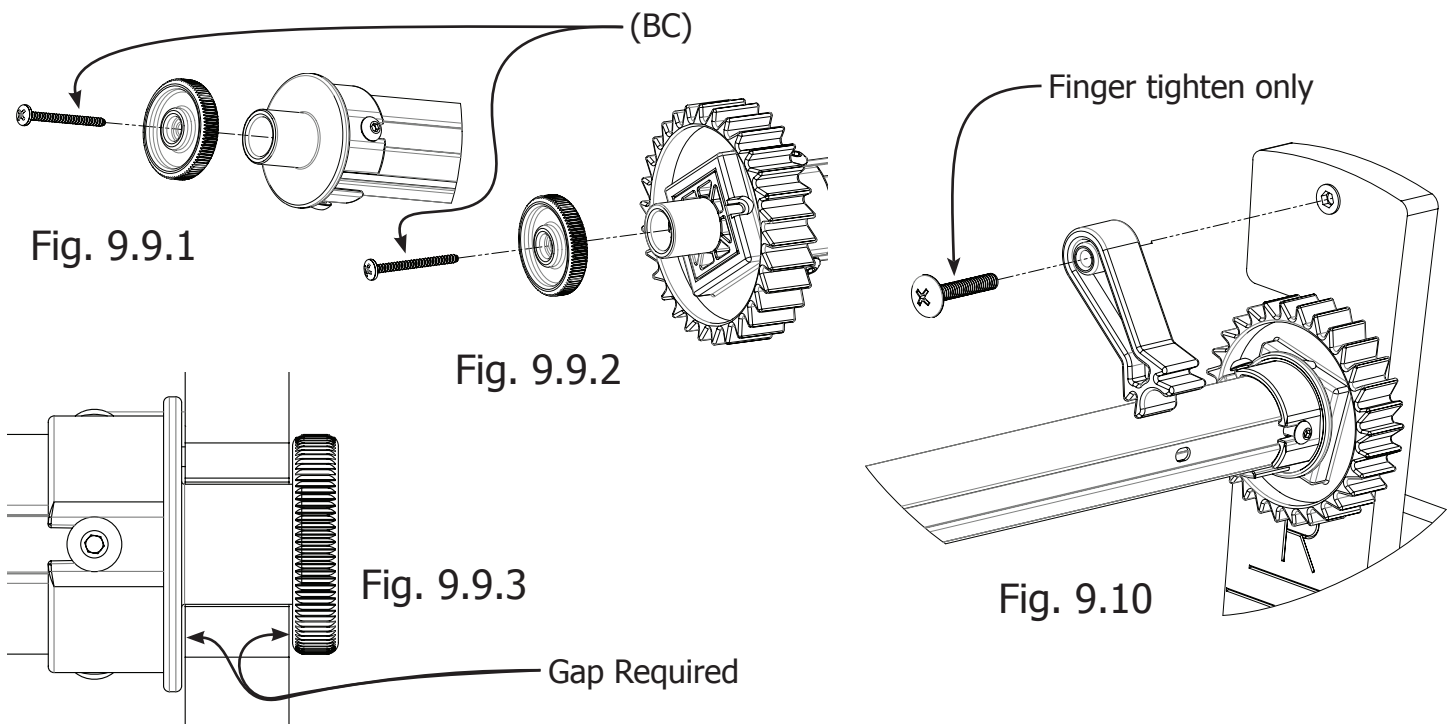

## **Step 10: Carriage**

Please refer to the instruction booklet included with the carriage. The carriage manual will guide you through the process of building your carriage and placing it on your quilting frame, as well as sewing machine placement.

Congratulations! You have completed the assembly of your Gracie Quilting Frame.

Save any extra hardware you have left over (if you assembled the crib size you will have bolts and wood pieces remaining).

Store these in a safe, dry place for later use.

All that remains is to install your fabric and begin quilting!

With the specially designed Fabri-Fast rails, installing your fabric is easier on the Gracie Frame than on any other frame. Each rail has a Fabri-Fast slot and accompanying tubing. These work together to make your fabric installation much easier and faster than using tape, tacks or Velcro®.

Before you begin, please locate the plastic Fabri-Fast tool included in your shipment.

We recommend you begin with practice material allowing you to experiment with machine settings and stroke techniques.

NOTE: As you cut your fabric layers, we recommend making the quilt backing about 6-8" longer and 2-4" wider than your top. This will allow for a little give in the backing, especially if using thicker batting.

## **Fabric Installation**

### **Methods of Installation**

- The recommended method for installing fabric onto the rails is to make and use **Cloth Leaders (instructions to follow)**. This will enable you to finish your quilt completely, to the end, without having to take your quilt off the rails.
- It is very important to cut all your fabric square. This will make the following steps much easier! A rotary cutter helps achieve more precise results.

The following is a brief overview to show which fabric layer goes on each rail.

### **OVERVIEW:**

**Step 1:** Load Batting to the batting rail and roll up.

**Step 2:** Load Quilt Top to the quilt top rail and roll up.

**Step 3:** Load Quilt Backing to quilt back rail and roll up.

**Step 4:** Attach Quilt Backing to Take-Up rail.

**Step 5:** Attach Batting to Take-Up rail.

**Step 6:** Attach Quilt Top to Take-Up rail.

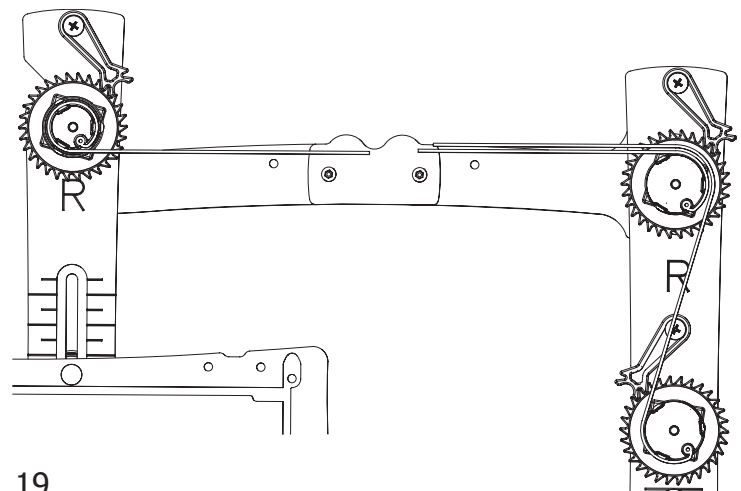
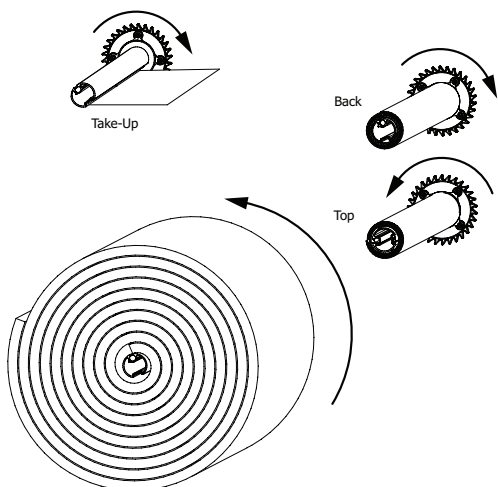

## Making Cloth Leaders

- First, select your cloth leader material. We recommend using a good quality muslin or similar fabric that has a good thread count. Be aware, however, that if the fabric is too thick, it may prove more difficult getting it installed into the rail slot.
- Surge or hem your cloth leaders on all sides.
- Make cloth leaders so that their lengths are as follows.

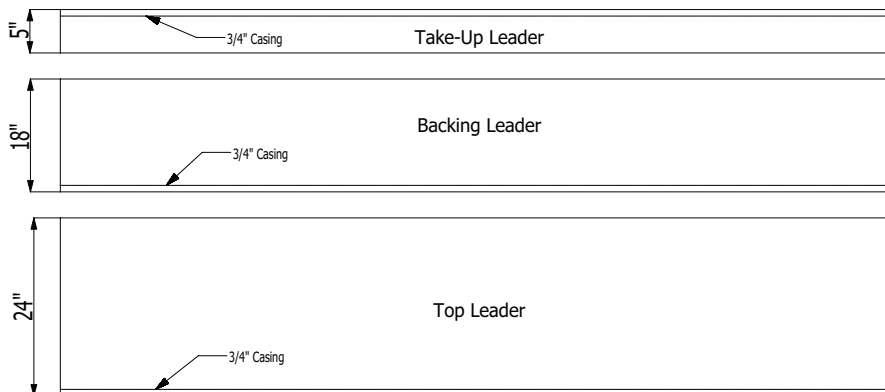

- Mark a dashed line along the length of your leader about 1/2" in from the edge. You will use this as a guide to help you insert your leader into the slot in a straight line. (OPTIONAL: For a straighter cloth leader installation, some may consider it easier to make a casing and push the tubing into the casing before installing it into the slot. If

you wish to do this, create a casing on one end of each leader by folding over the fabric one inch (1"), and, using your presser foot as a guide, stitching the fabric together 3/4" from the fold. This will leave about 1/4" of fabric beyond the stitching. Leave the edges open on both ends. You may then slide your tubing into the casing).

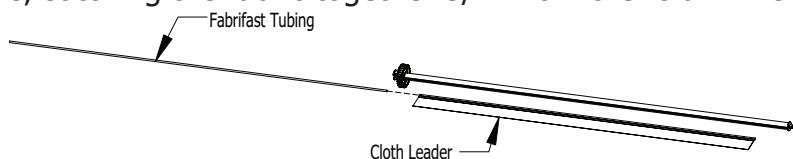

- Mark each cloth leader at the center (length-wise).
- Mark (or baste) a straight line about 1/2" in from the opposite (non-casing, or non-dashed) end of the leader. This will be the line to which you attach your fabric layer.
- Center your cloth leader lengthwise along the rail. Using Grace's Fabri-Fast™ System, take a piece of plastic tubing (cut to the appropriate length) holding your cloth leader to the slot (lining up the dashed line), and press the tubing over the leader and into the slot. Use the Fabri-Fast tool to press the rest of the tube and fabric in quickly and easily. If you have made a casing, line up the casing with tubing over the slot and press it into the slot using the Fabri-Fast tool.
- This illustration shows the cloth leaders installed on each rail prior to your quilt layers being installed.

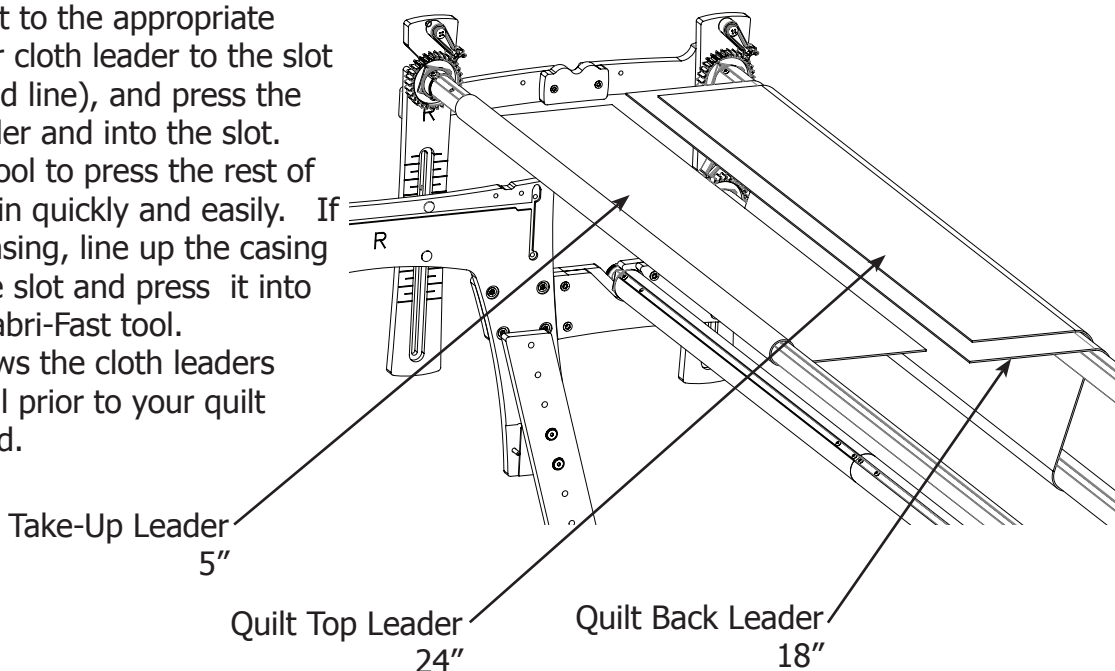

## **Installing Fabric Layers To The Rails**

.....

### **Step 1: Quilt Backing**

- To begin, determine which will be the front and back edges of your quilt Backing (be sure it will fit within the width of your frame set-up).
- **NOTE!** If your backing is made up of more than one piece of fabric, cut your selvages off and flatten them out to allow the backing the proper give it needs.
- Line up the center of your fabric layer with the center of the cloth leader on the backing rail. Pin the back edge of your backing to the leader cloth. This is to be done with the finished side of the fabric facing down.
- Do not stretch or pull the fabric during this process. Let it lay as naturally as possible.
- Roll your leader and backing onto the backing rail completely. Watch to make sure the fabric stays lined up. Smooth out any wrinkles as you roll by brushing the fabric from the center out. However, be very careful not to stretch or pull the fabric excessively.
- **NOTE!** It is important that you roll the rail the proper direction so the fabric rolls over and onto the backing rail (see picture Pg. 19).

### **Step 2: Quilt Top**

- Determine which will be the front and back edges of your quilt top.
- Line up the center of your fabric layer with the center of the cloth leader on the quilt top Rail. Pin the back edge of your top to the leader cloth. This is to be done with the finished side of the fabric facing up.
- Do not stretch or pull the fabric during this process. Let it lay as naturally as possible.
- Roll your leader and top onto the quilt top rail completely. Again, be sure the fabric stays lined up. Smooth out any wrinkles as you roll by brushing the fabric from the center out, being very careful not to stretch or pull the fabric excessively.
- **NOTE!** It is important that you roll the rail the proper direction so the fabric rolls onto the quilt top rail the right way (when fabric rolls off the rail toward the take-up rail, it should roll under and off the rail. See picture Pg. 19).

### **Step 3: Batting**

- A light, bonded batting is recommended.
- Center the batting on the batting rail and attach one end of the batting using the fabri-fast tubing. (NOTE: Fabri-Fast tubing will work with most batting, however, if the batting is too thick to squeeze into the slot, you may tape the batting to the rail to keep it in place).
- Roll the batting onto rail, being sure to roll the proper direction so that it, like the quilt top, comes off the rail from the bottom when unrolling.

### **Step 4: Attaching Layers To Take-Up Rail**

- Take the edge of the quilt backing and pin it along the straight line of the take up rail leader in a smooth manner, without stretching your fabric.
- Next, bring your batting up around the quilt backing rail, then under the quilt top rail, now drape it over the backing. Lay it along the pin line of your backing on the take up rail cloth leader.
- Finally, bring the quilt top up over the backing and batting, and lay it over the batting along the pin line on the take up rail cloth leader. Pin your top and batting along the same line as your backing in a smooth manner.

## **Rolling fabric**

- When you have completed your work area and are ready to roll to the next, simply take the stops off the Backing and Quilt Top rails, allowing them to roll freely. Then, with one or both hands, roll the Take-Up Rail forward, rolling the completed work area onto that Rail.
- **Note RF.1:** When rolling your fabric it may be necessary (to prevent over stretching quilt) to turn the Take-Up rail using one hand, and turn the Backing Rail using your other hand.
- **Note RF.2:** As you roll forward, the quilt will accumulate on the Take-Up Rail. Be sure to raise the Take-Up Rail Brackets slightly as needed, so that the bottom of the rolled up fabric stays about 1/4" above the throat plate of your sewing machine base. Failing to do so will cause your Carriage Assembly to roll less smoothly.

## **Quilt Block Size Considerations**

The Gracie Machine Quilting Frame is ideal for sewing machines with up to an 18" throat. The size of pattern you can sew is largely determined by the size of the throat of the sewing machine you will be using on the frame. With any machine you will need to consider the pattern size you want to sew before you begin quilting. As you begin planning the patterns you will sew on your quilt, there are several variables that you will need to consider: 1) size of the throat of your sewing machine, 2) Thickness of the batting you are using, 3) The size of the quilt. The three layers of fabric that make up your quilt will be rolled from their own rails, as they are quilted, to the Take-Up rail, which is the rail that passes through the throat of the sewing machine. (See Fig. QB.1) The larger the quilt and the thicker the batting, the larger the finished quilt roll will grow on the Take-Up Rail as you roll the completed areas up to move to your next work area. With a sewing machine that has a 9" throat, you would be able to sew a pattern up to 7" for your first row of patterns prior to having rolled any fabric onto the take up rail. By the end of your quilt the largest pattern you can sew could be reduced to as little as 4" depending on the batting thickness and length of the quilt that is rolled (in the throat of the sewing machine) on the Take-Up Rail. Because of this limitation, you will need to plan ahead and limit the maximum size pattern you are sewing as you begin your quilt so as to be able to finish the quilt with the same size pattern.

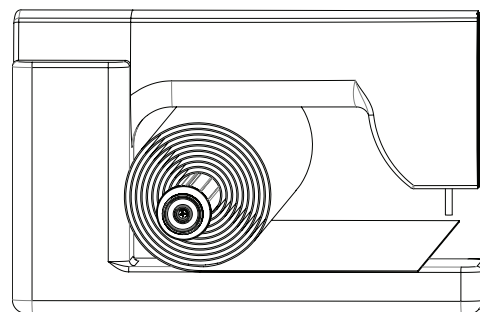

Fig. QB.1

## **Bungee Clamp Assembly**

Parts Needed:

- 4) Bungee Clamps
- 4) Bungee Stops

- Thread the end of each of your bungee cords through one of the available holes on the Bungee Arms, as shown.
- Slide a Bungee Stop onto the end of the bungee cord.
- Next attach the Bungee Clamp to the edge of your fabric.
- With the clamp attached to the fabric, pull the Bungee Cord through the hole until you get tension on the fabric. Now slide the Bungee Stop up the Bungee Cord to secure your tension.
- Follow the above steps for the rest of the Bungee Clamps.

