

ASSEMBLY INSTRUCTIONS

ITEM No.: 2011

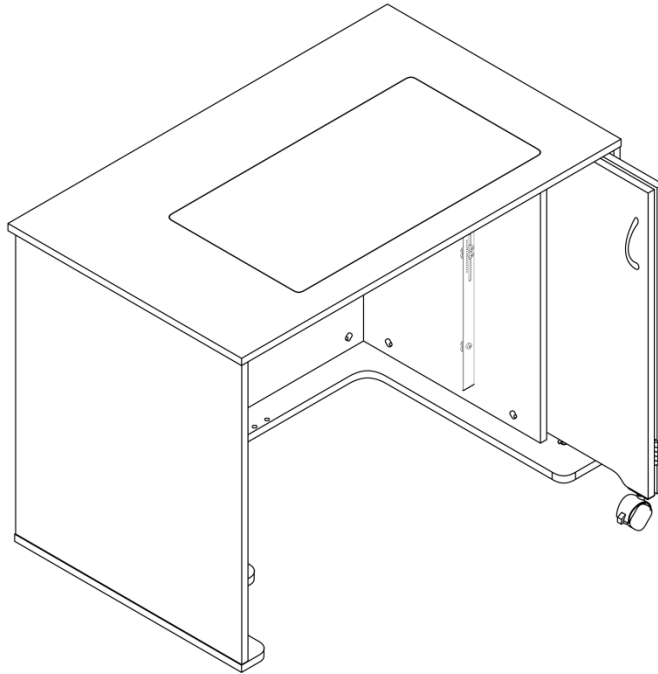

Assembly video can be found on our website at www.arrowcabinets.com in the Video Section.
Questions? Call 1-800-533-7347 press 1 or Email: cs@arrowcabinets.com



Turn clockwise to lock cam with bolt.

The arrow direction=front

Incorrect Correct

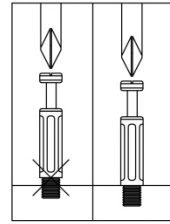



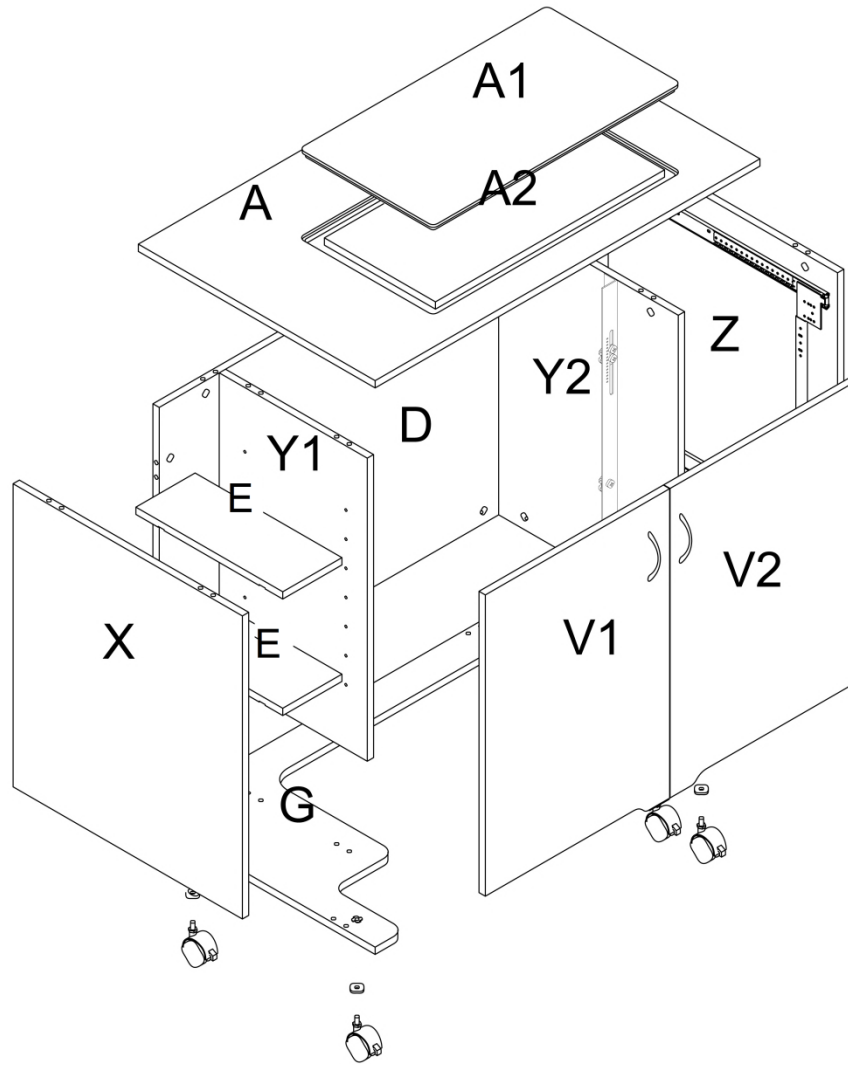

Screw cam bolts all the way in.



PARTS LIST

ITEM	DESCRIPTION	QTY.
A	Top panel	1
A1	Platform Cover	1
A2	Platform	1
G	Bottom	1
X	Left Side Panel	1
Z	Right Side Panel	1
Y1	Left Inside Panel	1
Y2	Right Inside Panel	1
D	Back	2
E	Shelves	1
V1	Left Door	1
V2	Right Door	1
O	Insert Holder	1

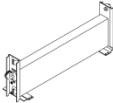
LIFTER PART LIST

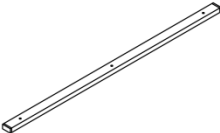
	Lifter Rail (Right)	1
	Lifter Rail (Left)	1
	Lifter (692mm)	1
	4*14 Screw	14
	metal bar support	1

PARTS LIST

ITEM	DESCRIPTION	QTY.	ITEM	DESCRIPTION	QTY.
c1	6*35 Cam Bolt	30	h	Handle	2
d1	8*30 Dowel pin	28	h1	Hinge	2
c2	(58") Cam Cover	32	b2	Fix Bolt	4
p1	Threaded Dowel Pin	8	b4	Washer	4
t1	Castor	5	s1	4*14 Screw	16
r3	14mm Spanner	1	g1	Hinge Body <small>*body & stand arrive together</small>	2
s4	3.5*10 Screw	2	g1	Hinge Stand	2
m	Magnet	1	s2	3.5*25 Screw	3
s7	4*6 Screw	4	s20	6*50 Fix Bolt	2



c1 6*35 Cam Bolt-30



d1 8*30 Dowel Pin-28

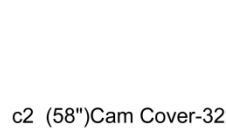

c2 (58") Cam Cover-32



t1 Castor-5

r3 14mm Spanner-1



s1 4*14 Screw-32



h Handle-2

b2 4*36 Fix Bolt-4

b4 Washer-4



p1 Threaded Dowel Pin-8

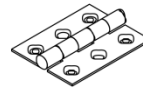

h1 Hinge-2

s7 4*6 Screw-4

g1 Hinge Body-2



g1 Hinge Stand-2

*g1 pieces arrive attached together in the same bag

s20 6*50 Fix Bolt-2

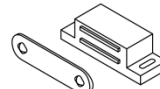

m Magnet-1

s2 3.5*25 Screw-3



s4 3.5*10 Screw-2



Pre-installed parts



c5 Cam

STEP 1

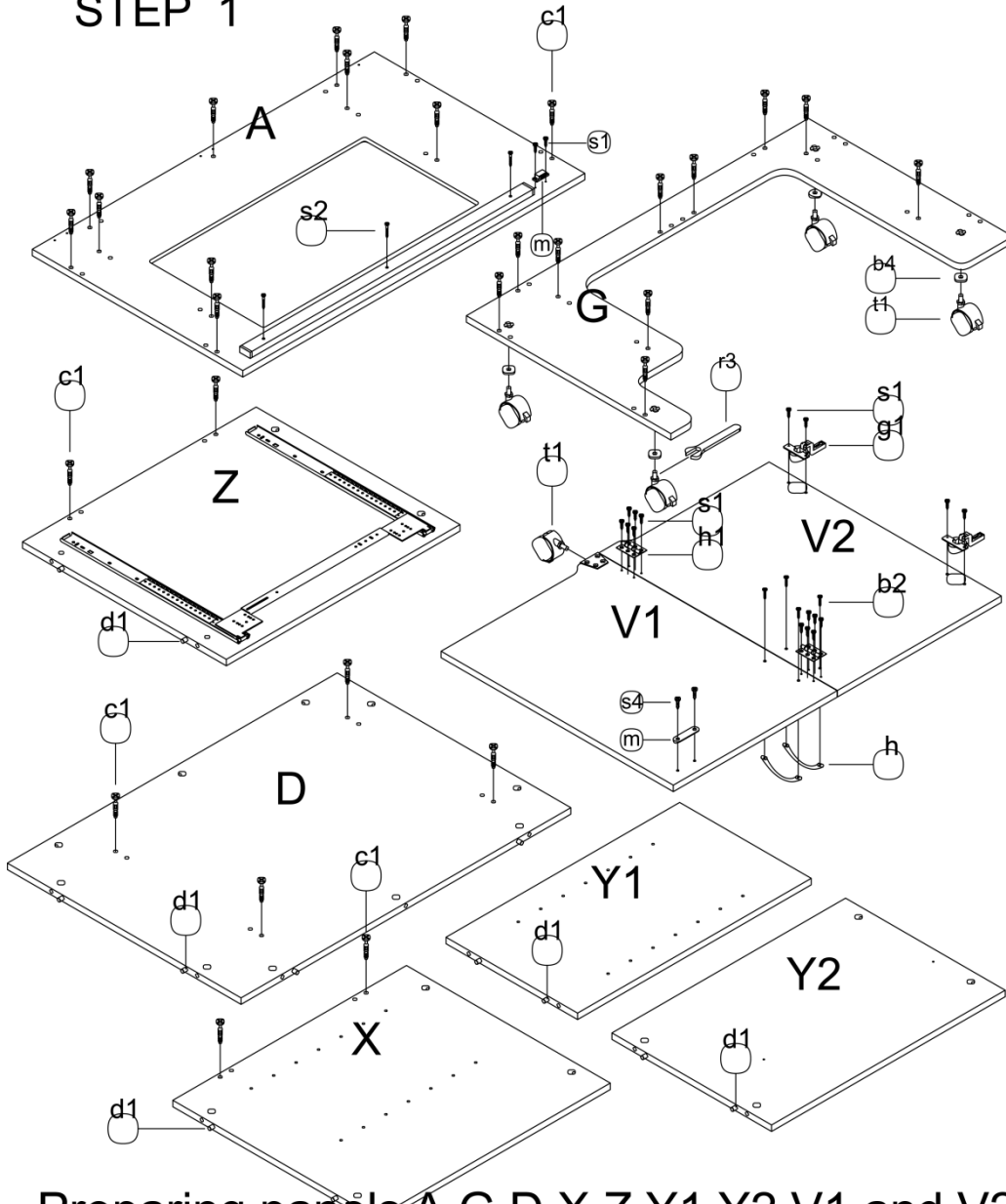

Preparing panels A,G,D,X,Z,Y1,Y2,V1 and V2

1. Insert cams bolts (c1) into panels A,G,X,D and Z as illustrated above.
2. Insert dowel pins (d1) to panels X,Z,Y1,Y2 and D as illustrated above.
3. Fix handles (h) to panels V1 and V2 with fix bolts (b2) as illustrated above.
4. Fix hinge bodies (g1) to panels V1 and V2 with screws (s1) as illustrated above.
5. Screw the metal bar support on to Top Panel A using the (s2) screws. Place in pre-drilled holes at front on panel.
6. Fix Hinges (h1) with screws (s1) into panels V1,V2 as illustrated above.
7. Attach locking casters (t1) to panel G by using the spanner tool (r3).
8. Attach magnet plate included with (m) on to panel V1 by using (s4) screws into predrilled holes in corner of panel.
9. Attach the door magnet (m) to Top Panel A using (s1) screws as illustrated above.

STEP 2

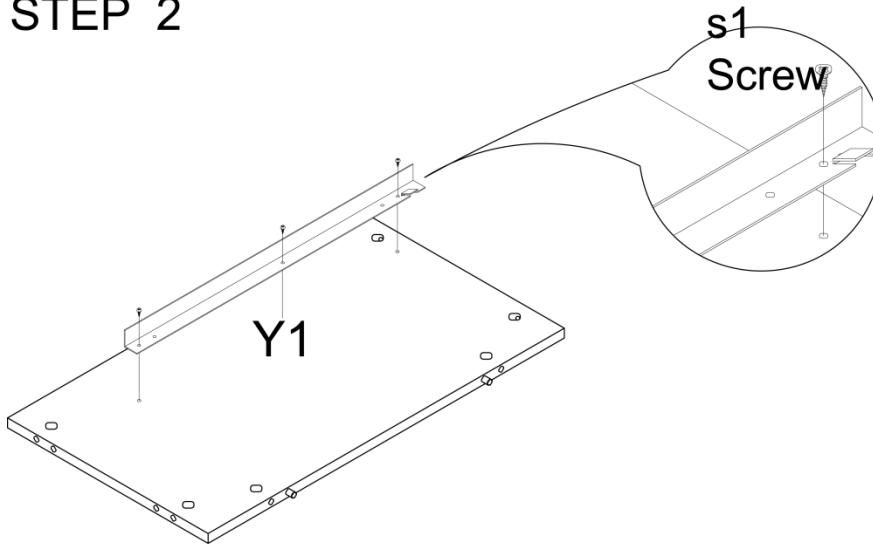

1. Fix Lifter Rail (left) to Y1 panel with s1 screws following predrilled holes as shown on the illustration above.

STEP 3

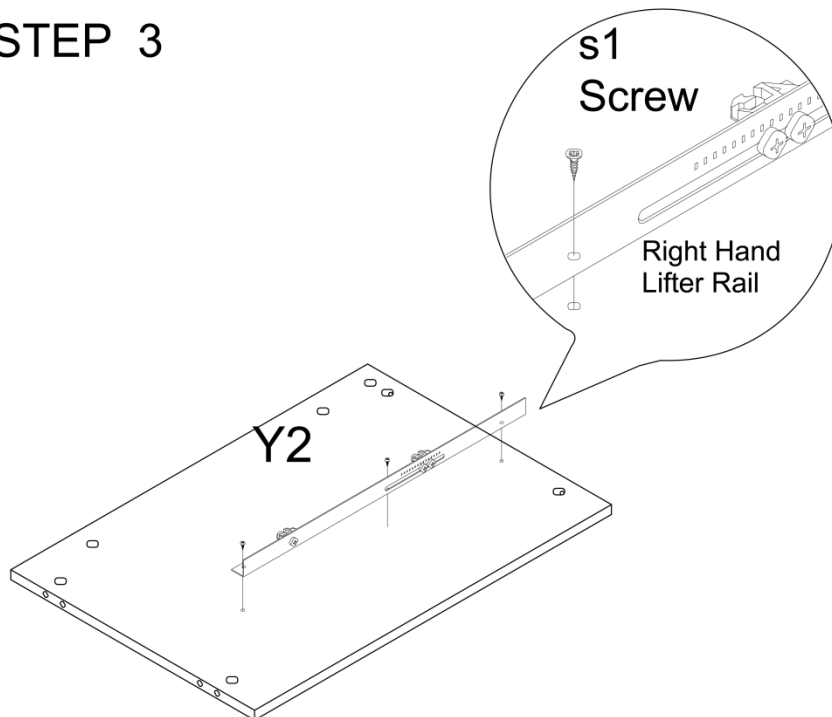

1. Fix Lifter Rail (right) to Y2 panel with s1 screws following predrilled holes as shown on the illustration above.

STEP 4

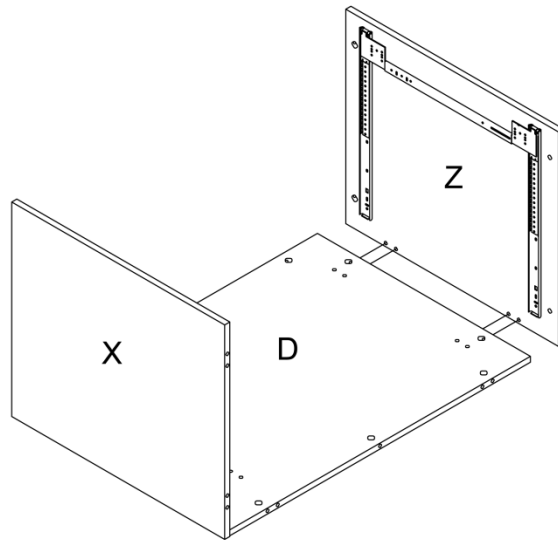

Panel D,X, and Z assembly.

1. Insert cam bolts ^(C1) on panel X and Z into cams on panels D and tighten in a clockwise direction as illustrated above.

STEP 5

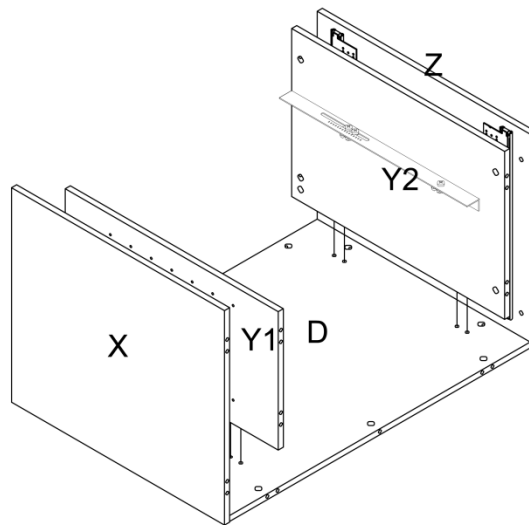

Panel Y1 and Y2 assembly.

1. Insert cam bolts ^(C1) on panel Y1 and Y2 into cams on panels D and tighten in a clockwise direction as illustrated above.

STEP 6

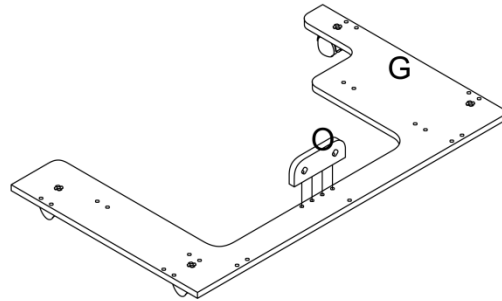



Panel O assembly.

1. Insert cam bolts  on panel G into cams on panels O and tighten in a clockwise direction as illustrated above.

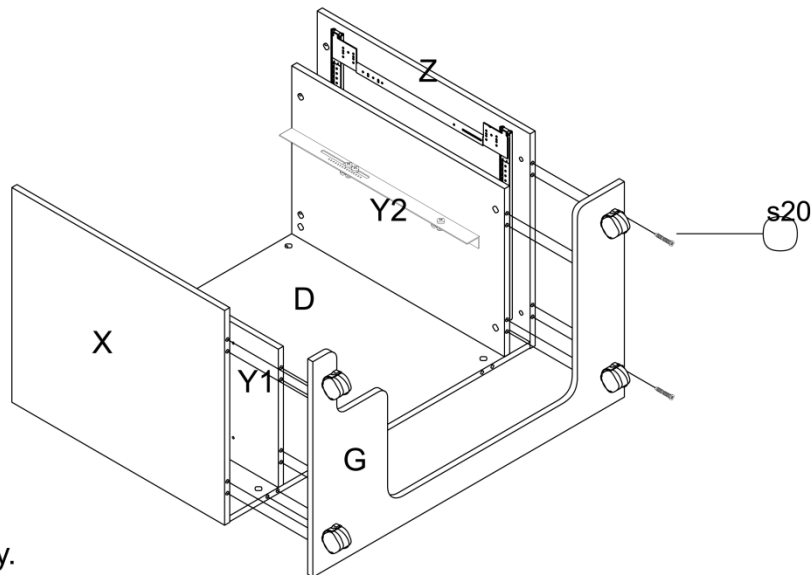
STEP 7



Panel G assembly.

1. Insert cam bolts  on panel G into cams on panels X,Z,D,Y1 and Y2 and tighten in a clockwise direction as illustrated above.
2. Insert screw  on panel G into holes on panels Z and tighten in a clockwise direction as illustrated above.

STEP 8

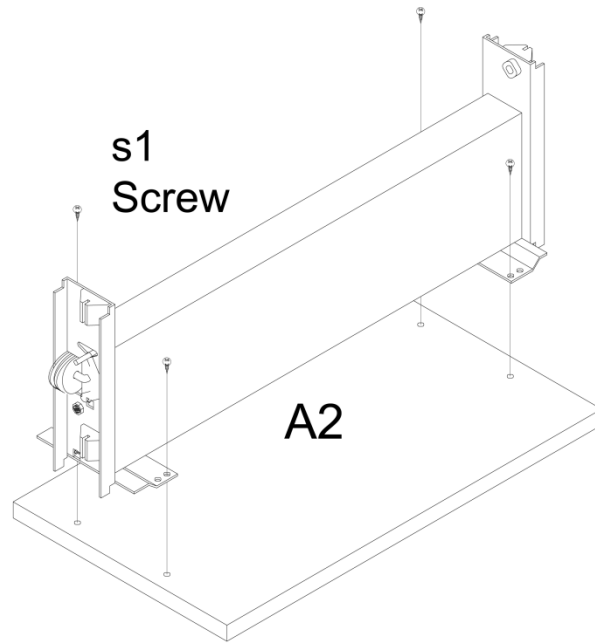

Lifter Panel assembly.

1. Fix Lifter to A2 panel with s1 screws following predrilled holes as shown on the illustration above.

STEP 9

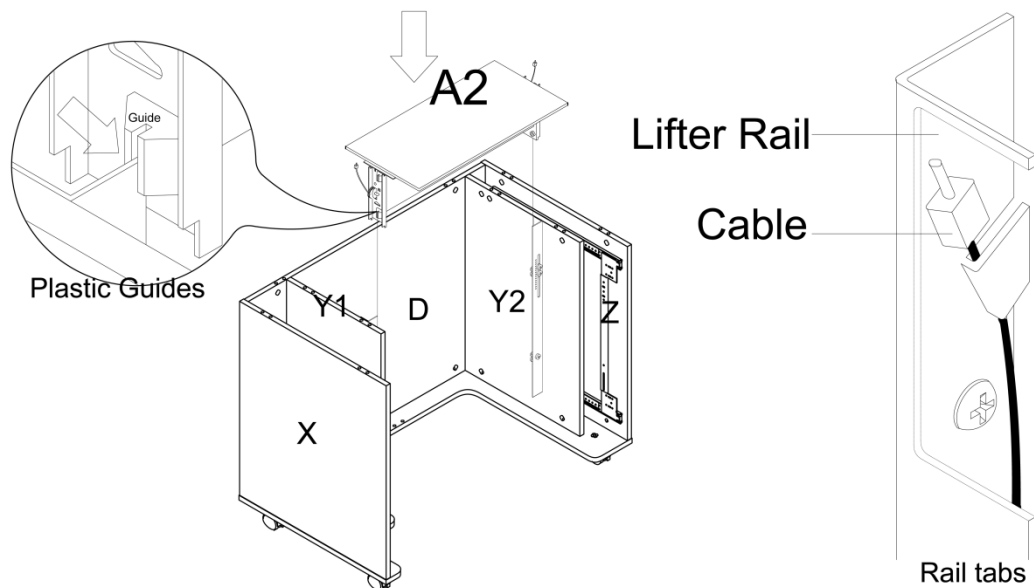

Mounting the Lifter Assembly.

1. Position lifter onto side rails using plastic guides; by lowering the lifter make sure the cable is catch onto the rail tabs on both sides. See illustration above.
2. When lifter pushed to first lock position remove a small wooden block that will be released from lifter.

STEP 10

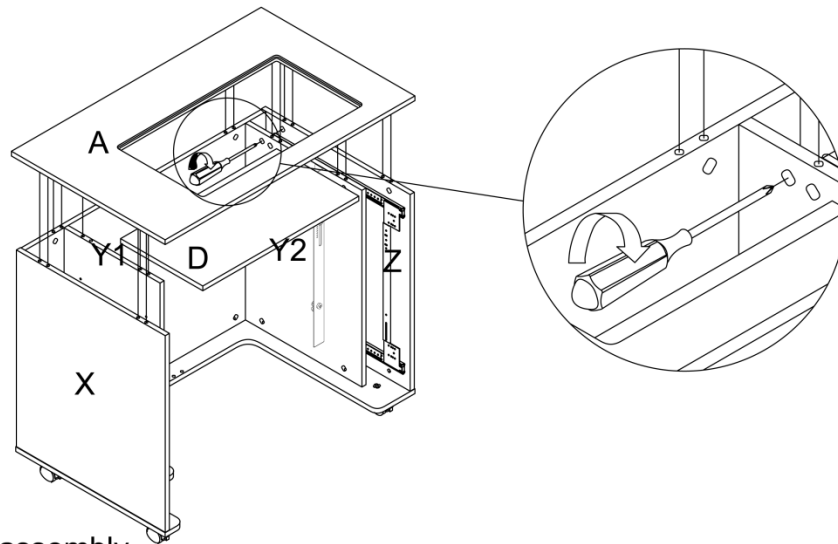

Panel A assembly.

1. Insert cam bolts ^(C1) on panel A into cams on panels X,Z,D,Y1 and Y2 and tighten in a clockwise direction as illustrated above.

STEP 11

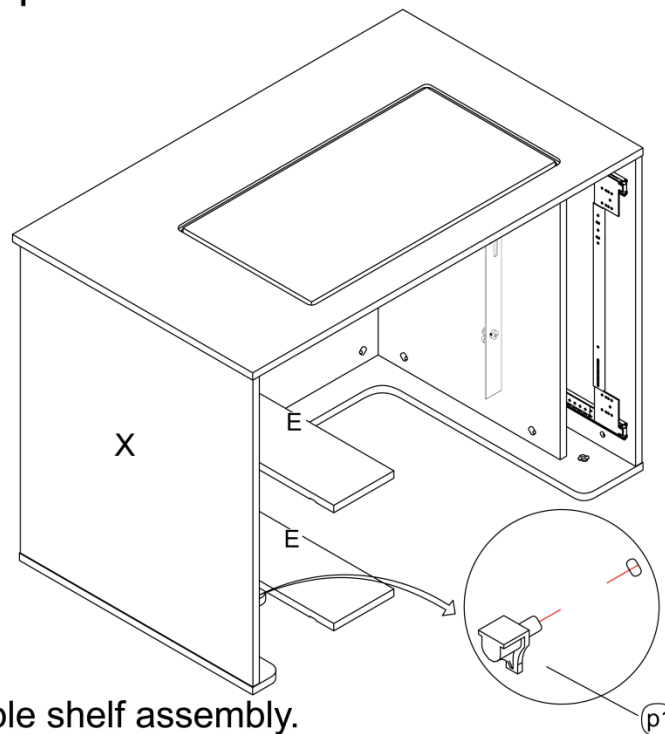

Moveable shelf assembly.

1. Press in ^(P1) pegs with flat surface facing upwards at the same level on panels X and Y1.
2. Slide shelf E with cut in grooves (if available) downwards on top of p1 pegs.

STEP 12

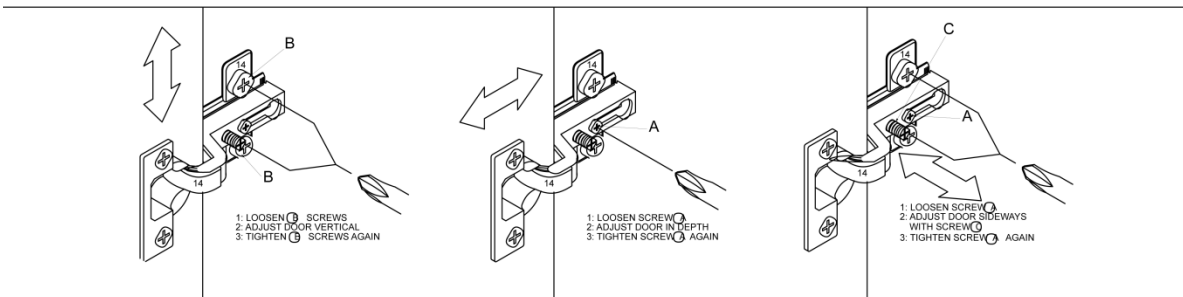
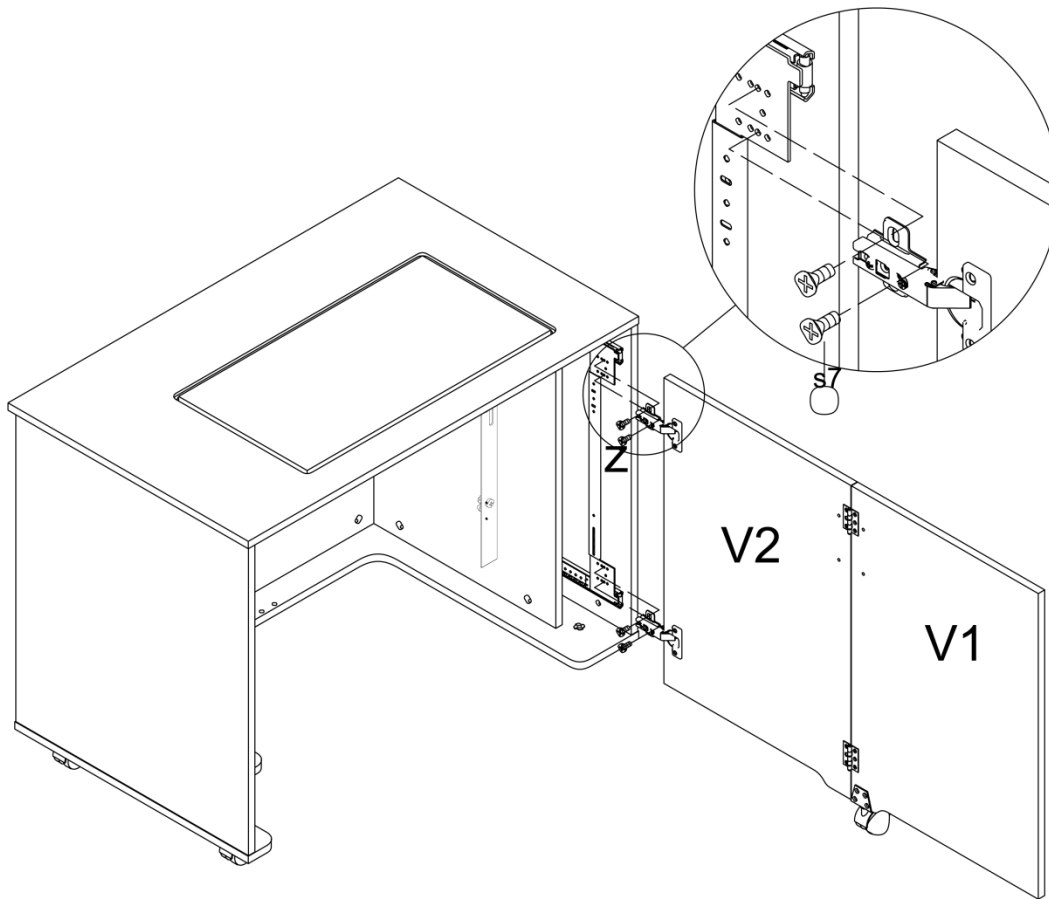

Door panel V1,V2 assembly.

1. Attach door assembly V1 and V2 to cabinet with screws S7 to panel Z runners as illustrated above.

You have now successfully completed the assembly on item:

ITEM NO.: 2011

