

Operating instructions
Rotary iron
HM 5316

To prevent accidents
and machine damage
read these instructions
before
installation or use.



M.-Nr. 06 858 370

Contents

IMPORTANT SAFETY INSTRUCTIONS	3
Guide to the rotary iron	5
Operating panel	6
Foot control bar	7
Finger guard	7
Use	8
Correct dampness	8
Preparing the laundry	8
Ironing tips	8
Ironing laundry	9
Steaming laundry	9
To feed thicker items	9
After ironing	9
Frequently asked questions	10
Power failure	10
Protecting the roller and iron cover	10
Motor protection	10
Cleaning and Care	11
Waxing the heater plate	11
Cleaning the heater plate	11
After sales service	13
Guide to the data plate symbols	14
Miele Ironing Handbook	15
Introduction	16
Caring for your rotary iron	18
Frequently asked questions	20
Installation instructions	23
Installation site	24
Installation	24
Air extraction	24
Condensate trap	24
Electrical connection	25
Help to protect the environment	26

IMPORTANT SAFETY INSTRUCTIONS

Read all instructions before installation or use. To prevent injury and machine damage.

Electrical safety

Be certain this appliance is properly installed and grounded by an authorized technician. To guarantee the electrical safety of this appliance, continuity must exist between the appliance and an effective grounding system. It is imperative that this basic safety requirement be met and tested. Consult a qualified electrician if in doubt. The manufacturer cannot be held responsible for damage which is the direct or indirect result of incorrect installation or connection.

Use

- This rotary iron is only intended for ironing fabrics washed in water. Check the fabric care labels to be sure the materials can be ironed.
- Only allow trained personnel to operate the machine.
- Do not let children play in, on or near the rotary iron. Do not let them play with the controls or operate the unit.
- Do not operate the rotary iron in a room where cleaning machines operate with solvents containing CFC.
- The rotary iron should only be used in a room with a relatively low humidity level.

- Be aware of loose fitting or hanging garments when using the rotary iron. Sleeves, apron ties, bracelets, etc. could be caught by the roller.
- Danger of burns when the heater plate is touched. Do not smooth an item between the heater plate and roller.
- When ironing double layered items, do not reach between the layers to straighten out the fabric. Burns could result if you cannot extract your hands before the laundry is pulled into the rotary iron.
- Do not reach into pockets when the open side faces the hot heater plate.
- Smooth creases on the feed board not right in front of the hot heater plate. Feed pillow cases and duvet covers into the rotary iron with the open end first.
- Test the finger guard before each use to avoid injury.
- Before switching into reverse, assure that no harm can be done to oneself.
- Do not place laundry on top of the heater plate. **Danger of fire!**
- Keep a fire extinguisher close to the machine in case laundry catches fire.

IMPORTANT SAFETY INSTRUCTIONS

Do not damage, remove or bypass any of the safety features and controls of the rotary iron.

Do not operate a machine with an electrical fault until repaired.

Repairs to electrical appliances should only be carried out by an authorized technician in accordance with local and national safety regulations. Repairs and other work by unqualified persons could be dangerous. The manufacturer cannot be held responsible for unauthorized work.

Faulty components must only be replaced with genuine Miele spare parts. Only genuine Miele spare parts can guarantee the safe operation of this machine.

Before installation or service, disconnect the power supply to the work area by removing the fuse or "tripping" the circuit breaker to the unit.

Any removable outer panels must be in place, and all moving or electrical parts shielded before the machine is operated.

Ensure that any person operating this machine is familiar with these safety instructions.

Turn the machine off before greasing any parts.

Regard the national and local codes and standards.

Using accessories

Only use genuine Miele accessories. If other parts are used, guarantee, performance and product liability claims may become void.

SAVE THESE INSTRUCTIONS

Guide to the rotary iron

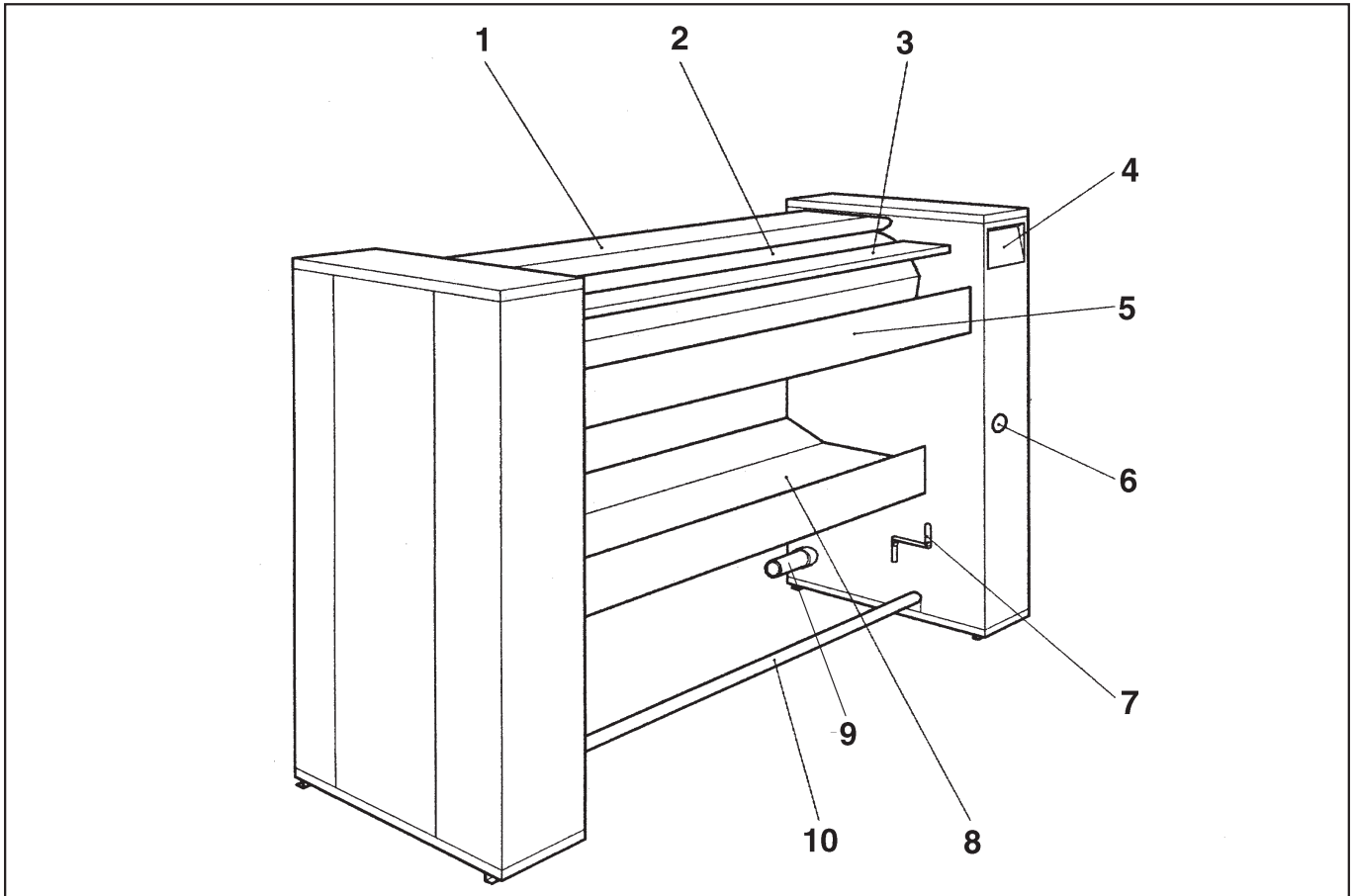

- 1 Heater plate with finger guard
- 2 Roller
- 3 Feed board
- 4 Operating panel
- 5 Laundry container
- 6 Cover for emergency handle insert
- 7 Emergency handle
- 8 Ironing table
- 9 Exhaust connector
- 10 Foot control bar

Guide to the rotary iron

Operating panel

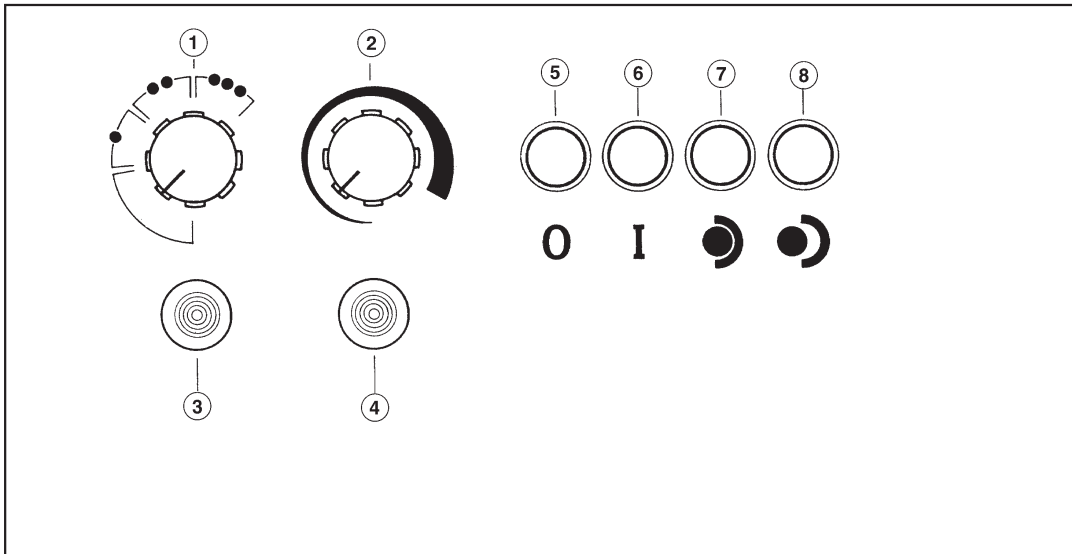

① Temperature selector

The temperature can be increased by turning the selector clockwise. It can be decreased by turning the selector counterclockwise.

- = Low temperature
- = Medium temperature
- = High temperature

② Roller speed selector

The roller speed can be increased by turning the selector clockwise. It can be decreased by turning the selector counterclockwise.

③ "Operating" indicator

The "operating" indicator lights, when the button "I" is pressed.

With coin mechanism:

The indicator lights, when the "I" button is pressed and a coin or token is inserted.

④ "Heating" indicator

Lights when the iron is heating.

⑤ Button "0"

Off

When the button is pressed, the rotary iron is turned off.

⑥ Button "I"

On

When the button is pressed, the rotary iron is turned on, the roller turns.

⑦ Button "○"

When the button is pressed the heater plate lowers.

⑧ Button "⊙"

When the button is pressed the heater plate raises.

Guide to the rotary iron

Foot control bar

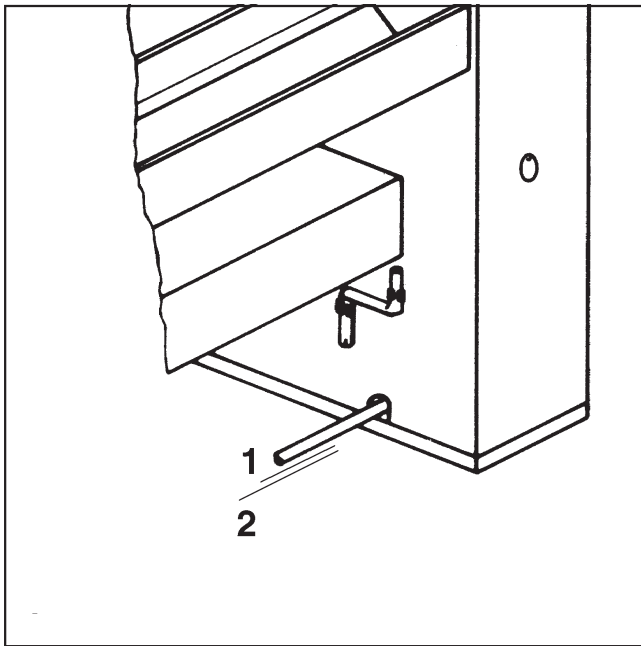



1st Switch point
Steaming, the roller stops

2nd Switch point and button "⊙" pressed:
The heater plate lowers and the roller turns.

2nd Switch point and button "⊙" pressed:
The heater plate rises and the roller turns
backwards. **Only for removing the ironing
cover and padding.** (See "Cleaning and
Care" for more information.)

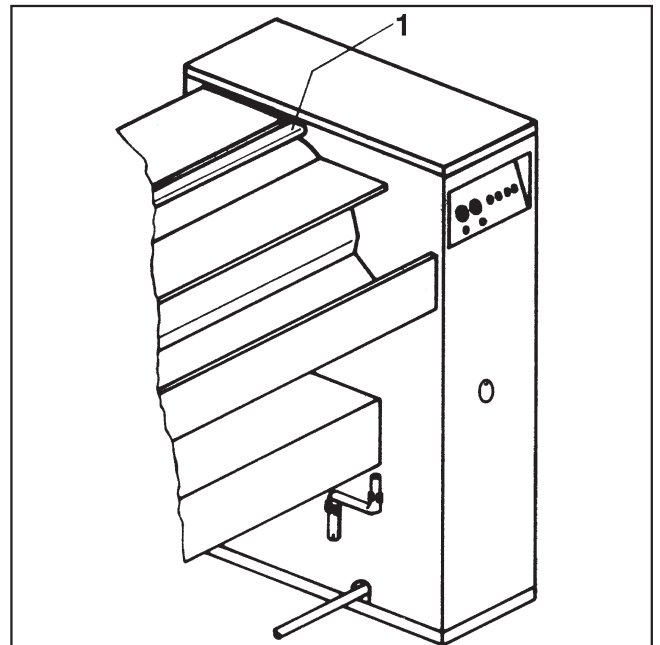
Finger guard



 The finger guard is a safety feature
which must be checked before each use
of the rotary iron.

If fingertips get between the feed board and
the finger guard **1**, the roller will stop and the
heater plate will rise.

■ Turn the rotary iron on again by pressing
the "I" button and "⊙".

Use





Correct dampness

For best results, the residual moisture of the laundry should be 25%.

Laundry which contains more than 50% synthetic fibers must not be ironed in this machine. The synthetics might melt at the high temperatures. Laundry with less synthetics can be ironed at a low temperature.

Preparing the laundry

- Sort the laundry according to how much heat is required for ironing.
- Check the fabric care label for the correct ironing temperature of the laundry.

Care symbol	Fabric	Dot symbol	Temp.
	Do not iron		
	Polyester / Rayon	●	cool iron (low temp.)
	Silk / Woolens	●●	medium hot iron (medium temp.)
	Cottons / Linen	●●●	hot iron (high temp.)

- Start ironing at a low setting and gradually increase the temperature according to the fabric being ironed.
- If decreasing the temperature is necessary, it is only reached, once the "Heating" indicator lights again.

Ironing tips

- To avoid creasing stop the roller, pull the item back slightly and smooth out. If necessary, dampen again with a wet cloth or spray bottle.
- If possible, always use the whole length of the roller, otherwise it will lose its elasticity.
- For small items such as handkerchiefs, alternate between the right and left hand sides of the roller.
- Iron starched items last to avoid any starch transfer to other items.
- Items with buttons, zippers or holes should be ironed face down on to the roller so that they are pressed into the cushioned surface.
- Cover zippers, metal buttons, and metal hooks with a cloth to protect the heater plate.
- Buttons, zippers and trim that is not heat resistant or very large buttons should not be ironed. They may damage the heater plate.

Caution!
Before using for the first time clean the heater plate by ironing an old cloth over the whole roller length.

Ironing laundry

- Turn the unit on at the wall switch.
- Ironing with coin mechanism:
Insert coins or token.
- Press "I" to turn the iron on.
- Select the temperature depending on the laundry with the temperature selector.
- Press the "☉" button.

The heater plate lowers when a temperature of about 140°F (60°C) is reached.

- Select a roller speed depending on dampness and type of laundry.
- Test the finger guard for proper operation.

 The finger guard is a safety feature which must be checked each time the rotary iron is used.

Once the "Heating" indicator goes out, the rotary iron is ready for operation.

- Insert the prepared laundry by feeding it over the feed board.
- Smooth the items during ironing from the middle to the edges.
- Use the whole roller width to iron small laundry items, alternating items from left to right.

If decreasing the temperature is necessary, it is only reached, after the "Heating" indicator lights again.

Ironing with coin mechanism:

Once the preprogrammed running time has counted down, the heater plate raises and the roller stops turning.

Steaming laundry

- To steam laundry, press the foot pedal down to the **1st** switch point.

The roller stops.

To feed thicker items

- Press the foot pedal down to the **2nd** switch point.

The heater plate raises off the roller.

- Release the foot pedal and the roller turns again.

 The ironed laundry can be very hot when coming right off the rotary iron. Wear gloves if necessary.

Let the laundry completely cool before packing or stacking. Hot laundry can combust. Danger of fire!

To increase the durability of the roller motor and the ironing cover raise the heater plate and lower the temperature during breaks.

After ironing

To dry the roller cover, turn the heat off and let the rotary iron run for 5 minutes with the heater plate lowered.

- Press the "☉" button to raise the heater plate.
- Turn the rotary iron off by pressing the "0" button.
- Turn the unit off at the main power switch.

Frequently asked questions

Power failure

If there is a power failure when the iron is in use, the heater plate will stay on the roller. The item being ironed will then be held there possibly becoming scorched. If no laundry is ironed the ironing cover could be damaged.

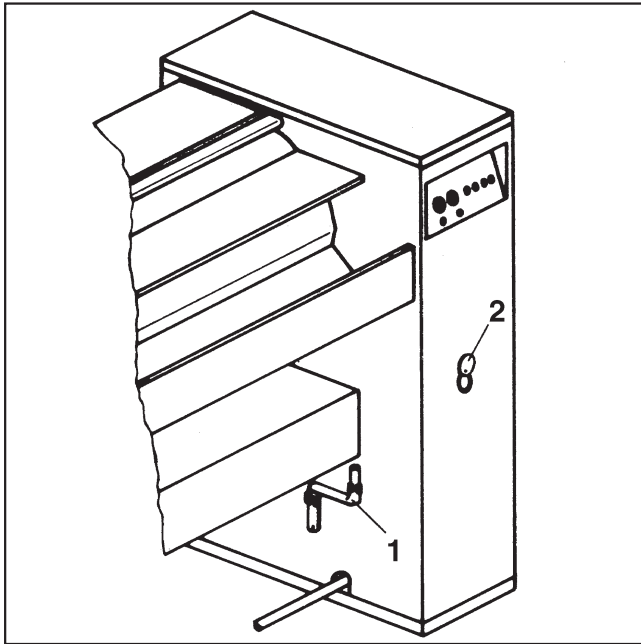

- Pull the emergency handle **1** from its bracket.
- Turn the cover **2** to the side.
- Insert the emergency handle in the opening.
- Turn the handle clockwise to raise the heater plate from the roller.

If the heater plate was raised and a noticeable resistance is felt, turn the handle twice counterclockwise.

- Remove the emergency handle after use from the opening and put it back in the bracket.
- When the power is restored, press the "I" button to turn the rotary iron on.

Protecting the roller and iron cover

- During breaks and after ironing the heater plate should be raised. The roller and the iron cover durability will be increased.

Avoid running the iron without laundry.

- Use the whole roller width to iron small laundry items. When used only on one side the roller and iron cover is strained.

Motor protection

If the motor gets too hot due to an overload, the motor shuts off automatically and the heater plate raises.

- After the motor has sufficiently cooled, press the "I" button and restart ironing.

Regular cleaning and maintenance of the heater plate is essential for the durability of the motor and roller pad and cover.

Waxing the heater plate

The heater plate should be **waxed daily** before use with a cleaning cloth for optimum performance.

Original cleaning cloths and ironing wax can be obtained from Miele.

- For cleaning and waxing the heater plate, set the roller speed to the lowest and the temperature to ●●●.

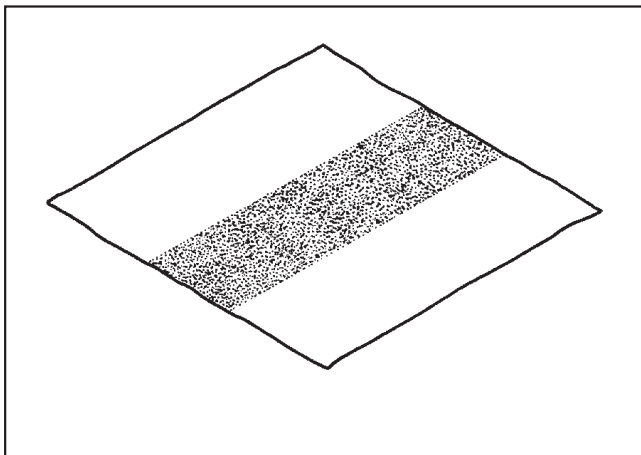

- Sprinkle the ironing wax on the middle part of a cleaning cloth (Miele accessory).

Only use a small quantity of wax.

Do not get wax on the roller, it will melt and damage the roller cover.

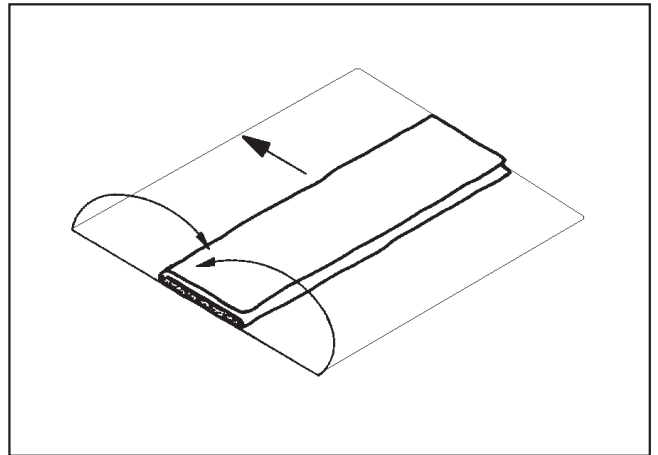

- Wrap the two ends over and feed the cloth into the rotary iron like a laundry item with the long side (arrow) first.
- Starting from left to right, the cloth is fed into the iron until the entire roller length is covered.

Cleaning the heater plate

Do not use abrasive cleaning agents, scrubbing sponges or sand paper.

- Lime and starch deposits can build up on the heater plate. Clean the heater plate **1-3 times per week** with an oil cloth and cleanpaste.
- For stubborn deposits use a cleaning cloth along with the cleaning mat.
- The heater plate must be waxed after each cleaning.

See "Miele Ironing Handbook" for further information.

Cleaning and Care

Discoloration of the ironing cover

A slight to heavily brown coloration of the ironing cover is normal.

To avoid the cover from turning black:

- Always use the complete roller width.
- Space out smaller items, alternating from left to right.
- Raise the heater plate and lower the temperature during breaks.

Washing the ironing cover

The ironing cover should not be washed if only slightly discolored (yellowing normal).

- A heavily soiled cover can be washed at a hot temperature 203°F (95°C), spun and returned to the roller while still damp.
- Before removing the ironing cover to clean or replace it, turn the rotary iron off, let the heater plate cool and remove the feed board.
- Unhook the laundry pick-off units off the roller one after another.
- Turn the rotary iron on "I" and raise the heater plate "☉".
- Press the foot pipe to the **2nd** switch point and remove the ironing cover while the roller turns backwards.

Applying an ironing cover

- Raise the heater plate and turn the rotary iron off.
- Lay the ironing cover on the roller (parallel).
- Turn the rotary iron on "I" and lower the heater plate "☉". The ironing cover is pulled in.
- Steel wool bits will fall on the ironing table when removing or replacing the ironing cover. Clean them immediately.

A repadding is necessary if an air gap is visible between the lower edge of the heater plate and the roller (laundry outlet).

To replace or renew the roller padding call Technical Service.

Laundry pick-off unit

Clean the tips of the laundry pick-off unit's to remove dirt and starch **every 2-3 months** or as needed.

- Pull the laundry unit out and clean with warm water.

Maintenance

Call Technical Service for the following maintenance.

- When the roller needs repadding, check and grease the swivel joints.
- Check and replace the carbon brushes.

In the event of a problem, please contact the Miele Technical Service Department at the phone number on the back of this booklet.

When contacting Technical Service please quote the model (M.-Nr.) and serial number (Fabr.-Nr.) of the machine. These can be found on the silver data plate.

Only use original Miele spare parts for maintenance or repairs on this machine.

Guide to the data plate symbols

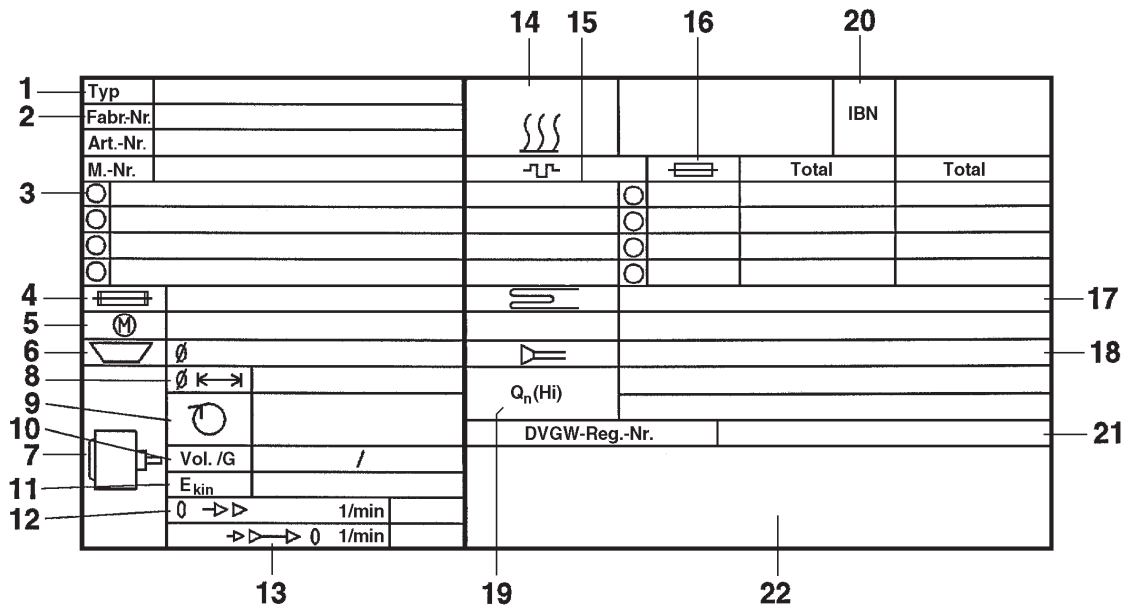

- | | |
|--------------------------------------|---|
| 1 Machine type | 15 Electric heating |
| 2 Serial number/Year of production * | 16 Fuse (on site) |
| 3 Voltage/Frequency | 17 Steam heating indirect |
| 4 Fuse rating | 18 Steam heating direct |
| 5 Drive motor | 19 Gas heating |
| 6 Plate diameter/Plate quantity * | 20 Commissioning date |
| 7 Drum data | 21 Water-Registration
DVGW-test cert (Water) |
| 8 Drum diameter/Drum depth | 22 Field for CE test symbol |
| 9 Spin speed | |
| 10 Drum volume/Laundry dry weight | |
| 11 Kinetic Energy | |
| 12 Ex. time to top speed | |
| 13 Breaking time | |
| 14 Heating | |
- * Not valid for this machine.

Noise level

Noise level was rated A.



Miele Ironing Handbook

Introduction

General notes on ironing

Correctly ironed laundry will be smooth, crease-free and not misshapen. However, in order to achieve this, the correct combination of mechanical energy, heat and steam is required.

Mechanical energy is achieved by producing the right amount of pressure and contact between the iron and the item passing through it.

Heat is needed to create steam, which helps make the fabric more pliable and easier to iron. To avoid damage to fabrics, the temperature must be right for the type of fabric being ironed.





Steam occurs when damp items are ironed at temperatures in excess of 212°F (100°C). When water changes to steam, it expands rapidly to heat and penetrate the fabric. As the moisture evaporates, a film of steam is created which helps the fabric glide through the rotary iron.

Fabrics suitable for ironing

Different types of fabric react differently to being ironed. Cottons and linens expand when wet, and ironing at a high temperature and pressure will make these fabrics smooth, shiny and dry.

Synthetic fabrics are sensitive to heat and melt at high temperatures. Manufacturers state the fibers used in the textiles on the care label, e.g. 65% cotton and 35% polyester.

Most care labels also carry washing instructions, in the form of international laundry care symbols. These symbols tell you whether or not the items can be ironed, and at which temperature setting.

Care symbol	Fabric	Dot symbol	Temp.
	Do not iron		
	Polyester / Rayon	●	cool iron (low temp.)
	Silk / Woolens	●●	medium hot iron (medium temp.)
	Cottons / Linen	●●●	hot iron (high temp.)

How fabrics should be ironed

- Buttons, zippers and ties should face the roller covering as they are fed into the iron to prevent them from damaging the heater plate.

Do not iron items with fringe, thin ties or straps. These could get tangled in the roller and cause a fault. Heat-sensitive items may be ironed at a higher temperature if a damp linen or cotton cloth is placed between the item and the heater plate.

Washing items prior to ironing

The washing process is very important. Follow the manufacturers guidelines on detergent. If too much detergent is used and is not fully rinsed, residues can be left on the laundry.

Depending on the hardness level of the water, limescale deposits can also occur in areas with a water hardness level greater than 4 (~21° dH or 3.8 mmol/l).

Drying laundry prior to ironing

For items to be completely dry after passing through the iron once, the laundry needs to be dried before ironing.

Good ironing results depend on the residual moisture level. A minimum residual moisture level of 25% is necessary to obtain a good finish. Starched items need a residual moisture level of at least 40%.

Cleaning and caring for heater plate

Regular cleaning and maintenance of the heater plate is essential for the protection of the motor and the roller cover, and helps to prolong the life of the machine.

A Nomex cleaning cloth with a Scotch cleaning mat can be used at maximum speed and temperatures up to 284°F (140°C). A Scotch cleaning strip can be used at temperatures up to 212°F (100°C). Wax must be applied to reduce friction.

Do not use abrasive cleaning materials, e.g. sand paper, to clean aluminum heater plates. A cleaning cloth should be used to remove heavy soiling, e.g. starch or limescale deposits.

Caring for your rotary iron

Accessories for cleaning

Nomex cleaning cloth

max. 284°F (140°C)

For **daily** removal of residue and starch from the roller.

Cleaning mat, round-grained

max. 284°F (140°C)

For **daily** removal of residue and starch from the roller.

Accessories for waxing

Wax cloth with pouch

max. 392°F (200°C)

For smooth ironing it may be necessary to wax the heater plate. Mostly used in commercial settings where the iron is used 40 hrs per week.

Wax

1.1 lb (0.5 kg)

Cleanpaste

6.6 lb (3 kg)

Use as needed. If items being pressed are heavily starched or if pressing starched items 8 hrs per day the iron may need to be cleaned using Cleanpaste once per week. If heavy starch is not used Cleanpaste may not be needed. **Use a different wax cloth to apply Cleanpaste, do not use the same cloth that has been used for wax.**

Waxing and cleaning

At the end of the workday or as needed (to clean light deposits): apply a small quantity of Cleanpaste with a clean wax cloth. This will loosen any minor soiling overnight, and help prevent the build-up of deposits on the rotary iron. For best results, use the whole width of the iron.

- Using a spatula, spread the Cleanpaste about 1 ¼ to 2 inches (3-5 cm) wide inside the cloth pouch.
- Close the pouch, and pass the cloth through the machine.

At the beginning of each working day: pass a cleaning cloth through the machine. This will remove any loosened deposits from the day before. For best results, use the whole width of the iron.

If needed, use a wax cloth with ironing wax. Only use a small quantity of wax in the morning. The iron can be used as required without adding any more wax.

- Place some granular wax in the pouch of the wax cloth.
- Close the pouch and feed the cloth through the iron with the non-rubber side facing the heater plate.
- Run the machine on the ●●● setting.

Use the wax sparingly to avoid the ironing cloth from becoming too smooth.

Caring for your rotary iron

How to use the cloth with pouch

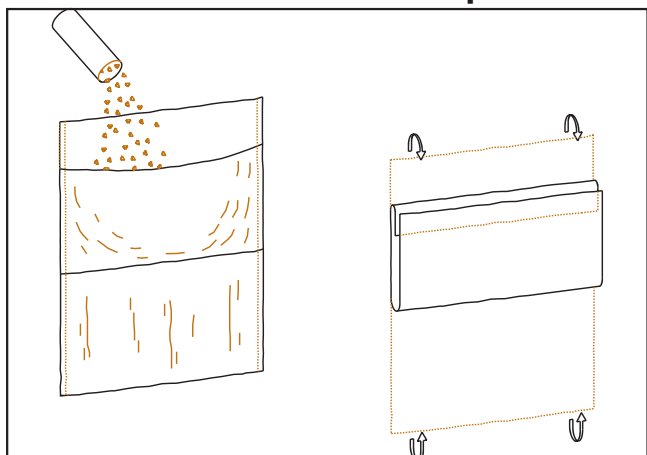

Passing a cleaning cloth or wax cloth through the rotary iron

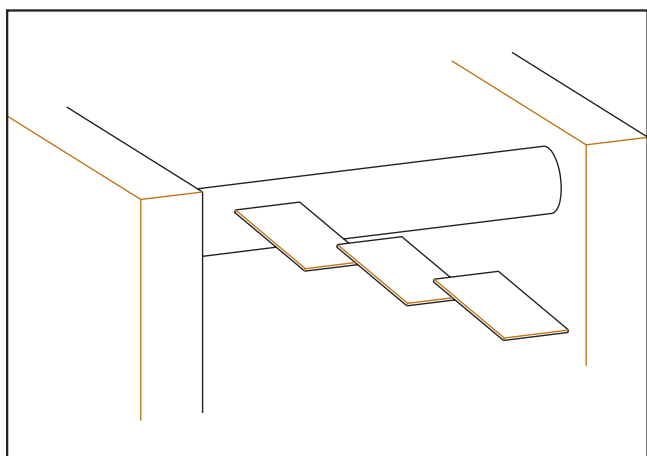

General notes

- Use separate cloths for ironing wax and Cleanpaste. The amount and frequency of application can vary according to use, as a general rule "Less is more".
- When using the cleaning cloth make sure that the maximum recommended temperature is not exceeded.

Do not use abrasive cleaning materials, e.g. sand paper, to clean aluminum heater plates. A cleaning cloth should be used to remove heavy soiling, e.g. starch or limescale deposits.

Removing and replacing the cover

Washing the iron cover

In cases of severe soiling, the iron cover should be washed using a very hot wash program.

Removing the iron cover from the roller

On irons with leaf-type padding the iron cover must be removed very carefully to prevent it from snagging and damaging the padding. The bottom layer of the cover must be carefully eased away from the padding.

Fitting the iron cover on the roller

If a new ironing cover is being fitted it should first be washed in a Cotton or Normal program. See "Cleaning and Care" for more information.

Frequently asked questions

Creases and wrinkles	
Possible cause	Solution
Limescale deposits	<ul style="list-style-type: none"> - Adjust the quantity of detergent to the water hardness in your area. - If necessary, install a water softener - Clean the heater plate
Detergent deposits	<ul style="list-style-type: none"> - Adjust the quantity of detergent - Ensure a sufficient number of rinses are carried out - Clean the heater plate
Starch deposits	<ul style="list-style-type: none"> - Clean the heater plate
Too much residual moisture	<ul style="list-style-type: none"> - Dry the wash until it has reached the recommended residual moisture level. - Reduce the roller speed
Not enough residual moisture	<ul style="list-style-type: none"> - Dampen the laundry until it contains 25% residual moisture.
The iron cover is too smooth	<ul style="list-style-type: none"> - Wash or replace the cover - Clean the heater plate
The exhaust duct is faulty (roller is too cold or damp)	<ul style="list-style-type: none"> - Reset the throttle valve (tighten as much as possible) - Check the ducting and the condensate trap in the ducting <p>Contact Miele Technical Service</p>
Too much padding	<ul style="list-style-type: none"> - Have the padding adjusted <p>Contact Miele Technical Service</p>
Temperature too high/too low	<ul style="list-style-type: none"> - Have the temperature control, heater elements, thermostat and limiter tested. <p>Contact Miele Technical Service</p>
The laundry or the cleaning cloth go through at an angle	
Possible cause	Solution
Machine is not leveled correctly	<ul style="list-style-type: none"> - Have the machine checked for correct installation <p>Contact Miele Technical Service</p>
Ironing in once place has caused padding to become uneven	<ul style="list-style-type: none"> - Use the full width of the iron evenly
Padding is uneven	<ul style="list-style-type: none"> - Adjust the padding as necessary <p>Contact Miele Technical Service</p>
Uneven contact due to deposits on the heater plate	<ul style="list-style-type: none"> - Clean the heater plate
Pressure is uneven	<ul style="list-style-type: none"> - Have the pressure checked <p>Contact Miele Technical Service</p>
Padding has deteriorated around the exhaust ducting	<ul style="list-style-type: none"> - Have the exhaust ducting checked - Replace padding (contact Miele Technical Service) - After use, turn off the heat and run the iron for 5 minutes to dry out the padding, see "Use - After Ironing".

Frequently asked questions

Discoloration of the iron cover	
Possible cause	Solution
Brown/Dark yellow: Normal due to heat from roller Black (striped or patches): Fibers or plastics may have melted or burnt to the iron	<ul style="list-style-type: none"> – Clean the heater plate – Wash or replace the iron cover – Use the recommended temperature for the fabric being ironed – Use only original Miele spare parts
Jet-black on ends of roller which has occurred very quickly.	<ul style="list-style-type: none"> – Check the air supply to the room. Get fresh air into the room if necessary. – When items to be ironed are too dry, static build-up can occur which attracts dust. Increase the residual moisture in the wash. – Running the ironer empty too long can cause a build-up of static. Use wax or cleanpaste. – Wash or replace the iron cover if it becomes dirty – Incorrect operation due to uneven ironing
Water marks or stains on the laundry	
Possible cause	Solution
Item does not come in contact with the iron	<ul style="list-style-type: none"> – Make sure padding is fitted evenly with no holes or gaps – Make sure the ends of the iron cover are well brushed out to ensure a smooth finish and to prevent water marks on the laundry <p>Contact Miele Technical Service</p>
Water marks or rust stains on the padding	
Possible cause	Solution
Padding was not ironed dry after use	<ul style="list-style-type: none"> – Iron the padding dry after use – Throttle valve needs service, contact Miele Technical Service.
Damp air is getting into the roller and padding from the outside	<ul style="list-style-type: none"> – Check the air supply to ensure that damp air, e.g. from a tumble dryer, is not getting into the iron or roller
Extraction ducting is too short	<ul style="list-style-type: none"> – Check venting direction – Have a non-return flap installed
Ducting is blocked or too narrow	<ul style="list-style-type: none"> – Have ducting tested – Have the exhaust system cleaned <p>Contact Miele Technical Service</p>
Build-up of static	
Possible cause	Solution
Fabrics attract static during ironing	<ul style="list-style-type: none"> – Increase humidity in the room where the iron is operated – Increase the residual moisture in the items to be ironed – Contact Miele Technical Service to adjust the exhaust emission levels – Provide rubber insulation mats for users to stand on – Use a static reducing detergent or fabric softener

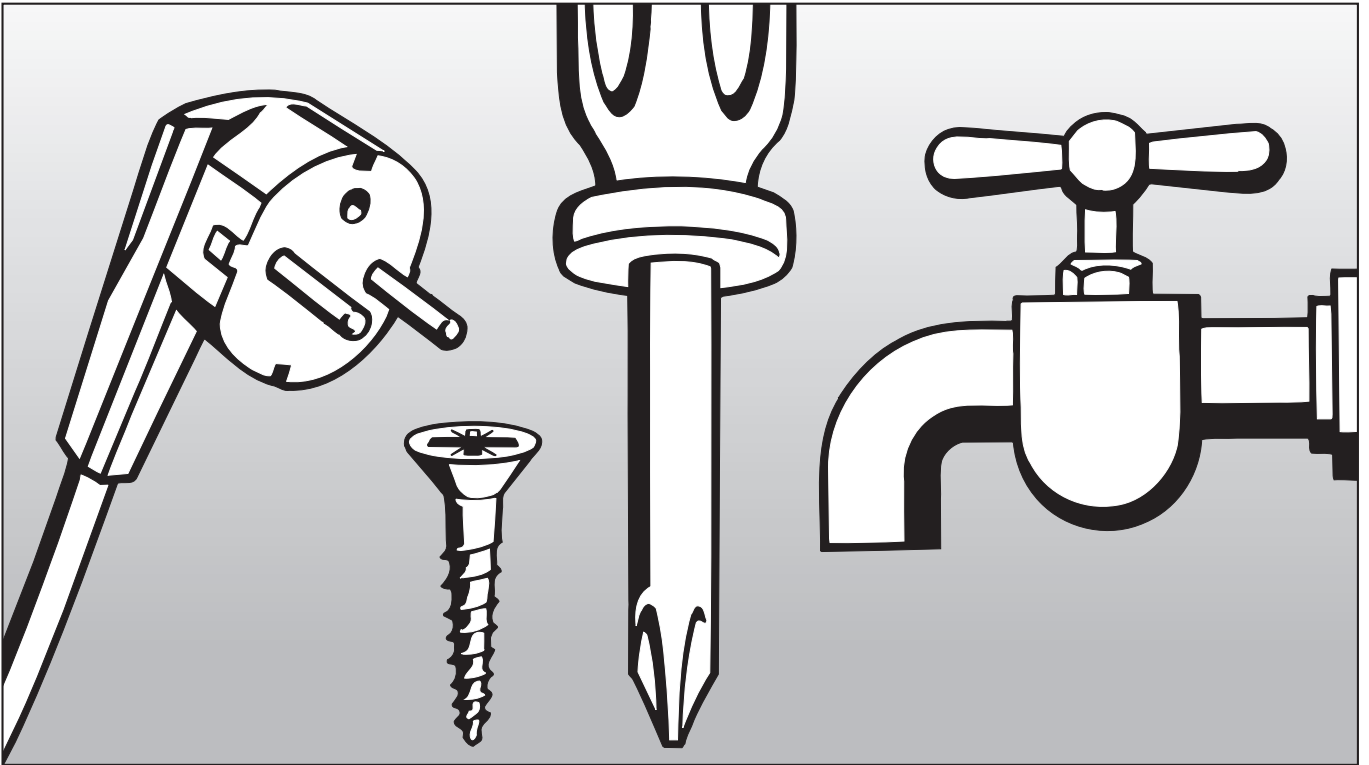

Installation Instructions

Installation instructions

The rotary iron should be installed by a Miele trained installer.

Installation site

⚠ Do not operate the rotary iron in a room where cleaning machines are operated with solvents containing CFC. These vapors could damage the machine.

The machine does not require any special anchorage or base installation.

- Select a location which has sufficient light for comfortable operation.

Installation

- Level the rotary iron with the 4 height adjustable feet. Hold the level on the front and side columns.

Air extraction

- The on-site ducting must not be connected to a chimney which is used by gas, solid fuel or oil fire boilers. It must be kept separate from any dryer exhaust system.
- The warm, moist exhaust should be discharged outside by the shortest route possible.
- To ensure optimum air flow, the ducting should contain as few bends as possible and airtight connections.
- Cover the open end at the outside with a weather hood.

Condensate trap

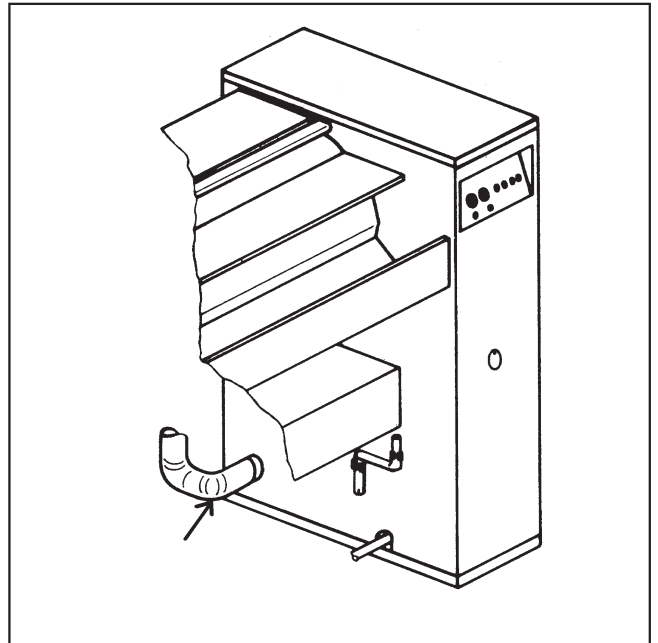

A condensate trap must be installed at the lowest point to prevent condensation from collecting in the duct.

Electrical connection

 All electrical work must be performed by a qualified service technician in accordance with all applicable codes and standards.

- Regard the data plate, wiring diagram, conversion and installation plan.

The wiring diagram is located under the cover of the right side column.

The machine is supplied for 230V, 60 Hz, 3AC.

- If converted to another voltage, mark it with  on the data plate.

 Caution! The heater plate rises as soon as the machine is connected to the mains.

Help to protect the environment

Disposal of the packing materials

The packing materials protect the appliance during shipping. They have been designed to be biodegradable and recyclable.

To prevent suffocation, ensure that any plastic wrappings, bags, etc. are disposed of safely and kept out of the reach of children.

Disposal of an old appliance

Old appliances may contain materials that can be recycled. Please contact your local recycling center about the possibility of recycling these materials.

Ensure that the appliance presents no danger to children while being stored for disposal. Before discarding an old appliance, unplug it from the outlet, cut off its power cord and remove any doors to prevent hazards.

Miele

PROFESSIONAL

Miele, Inc.

National Headquarters

9 Independence Way

Princeton, NJ 08540

Phone: 800-991-9380

609-419-9898

Fax: 609-419-4241

www.mieleusa.com

Technical Service & Support

Nationwide

Phone: 800-991-9380

Fax: 888-586-8056

Mid-West Region

Phone: 800-666-6740

Fax: 847-714-9434

West-Coast Region

Phone: 800-245-8215

Fax: 415-241-6822

Miele Limited

National Headquarters

55G East Beaver Creek Road

Richmond Hill, ON L4B 1E5

Phone: 800-565-6435

905-707-1171

Fax: 905-707-0177

www.miele.ca

professional@miele.ca