

Dream Fabric Frame

Assembly Instructions

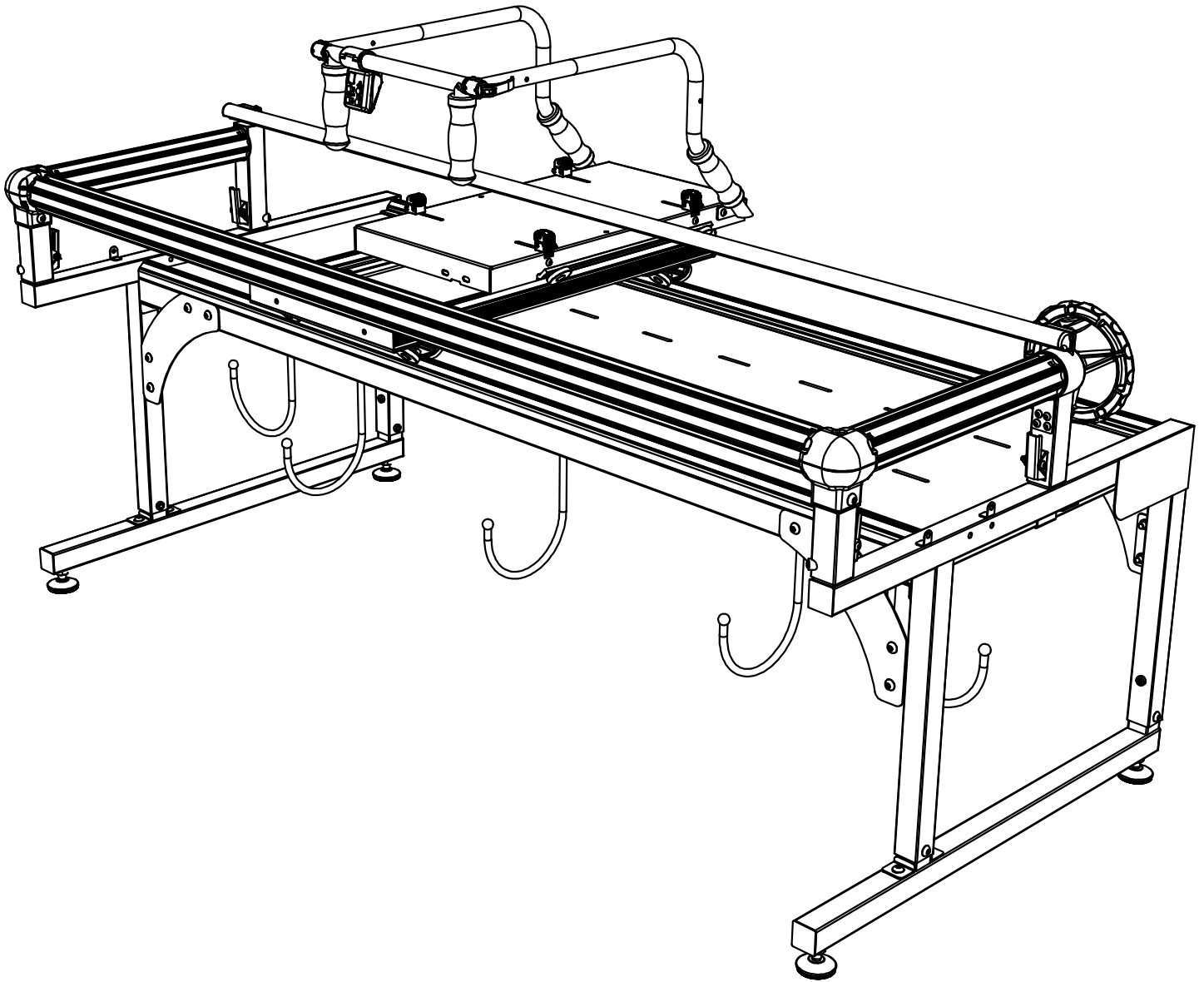

Copyright May 01, 2015
Jim M. Bagley, GraceWood, Inc
(Reproduction Prohibited)
Version 1

Table Of Contents

Parts List	3
Step 1: Table Set Up	6
Step 2: Install the Hand Wheel	8
Step 3: Install the Front Rail	8
Step 4: Top Plate Assembly	10
Step 5: Place the Sewing Machine	11
Step 6: Install the Back Rail	11
Step 7: Adjust Fabric Height	13
Step 8: Control Box Set-up	14
Step 9: Sure Stitch Installation	15
Step 10: Adjust Leveling Feet Height	19

Parts List

Box 1



Front Rail (1)

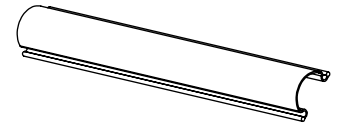

Front Rail Clamp (2)

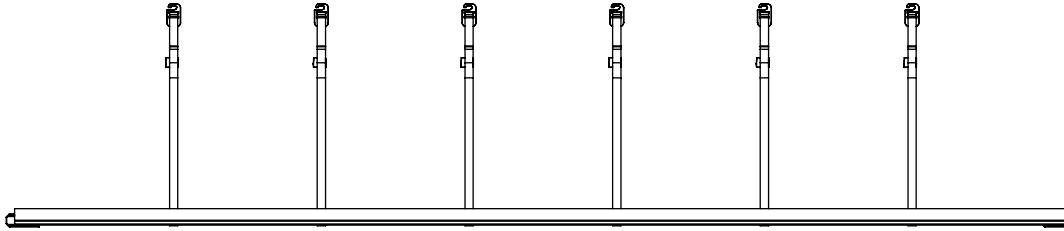

Back Rail (1)

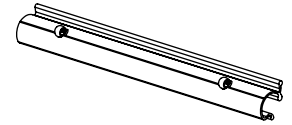

Back Rail Clamp (3)

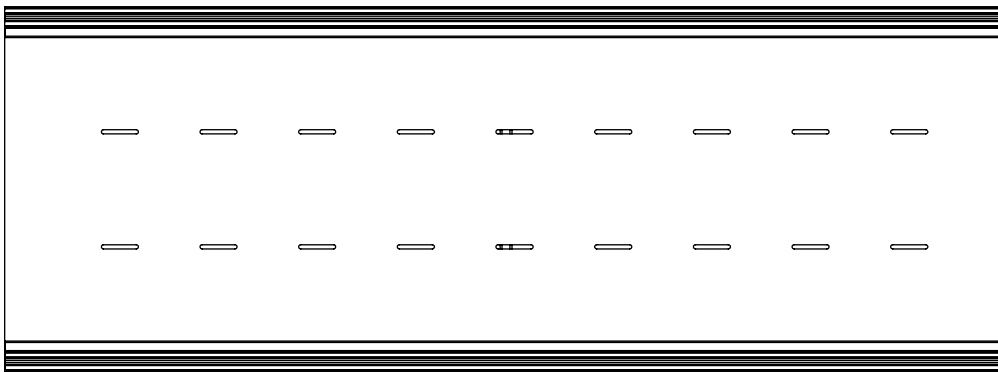
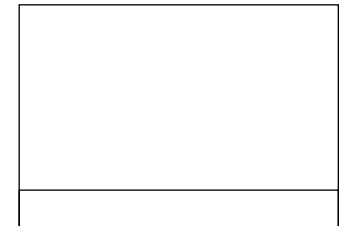

Table Top (1)



Cloth Leaders (4)

Box 2

Sure Stitch Box

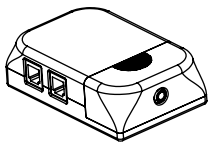

Control Box (1)

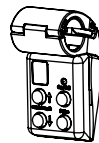

Display Box (1)

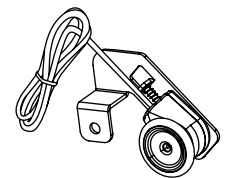

Encoder with Encoder Cable(2)

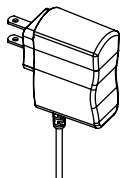

Power Supply (1)

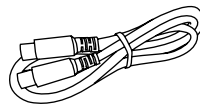

Sure Stitch Display Cable (1)

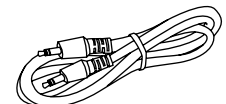

Sure Stitch Sewing Machine Cable (1)



Ziptie (8)



Ziptie Mount (6)



Velcro Strap (6)



2.5mm Allen Wrench (1)

Box 2 Continued

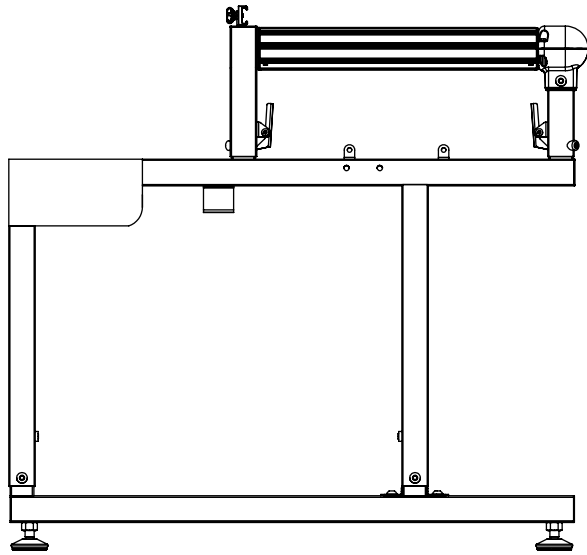

Left Leg (1)

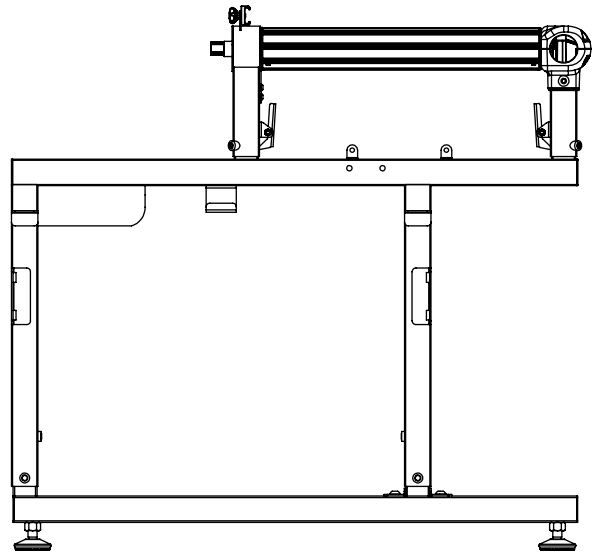

Right Leg (1)

Inner Box 1

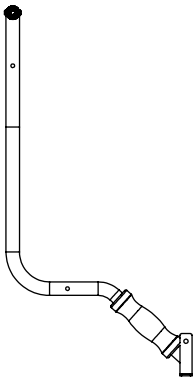

Handle Left (1)

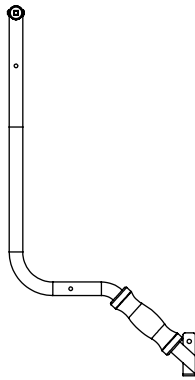

Handle Right (1)

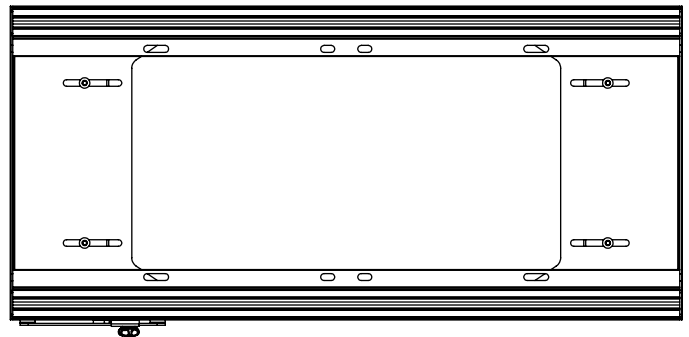

Bottom Plate (1)

Inner Box 2

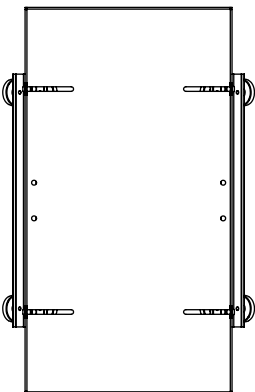

Top Plate (1)



Handle Crossbar (1)



Carriage Bolt and Clamp (1)



Sewing Machine Clamp (4)

Inner Box 3

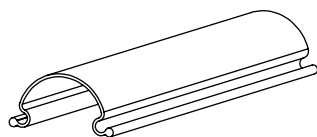

Side Rail Clamp (2)

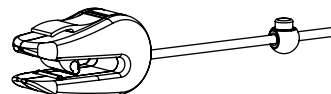

Bungee Clamp with Bungee Stop (4)

Box 2 Continued

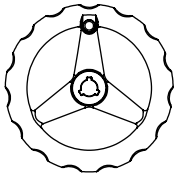

Large Hand Wheel (1)

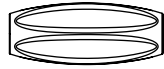

Long Knob (1)

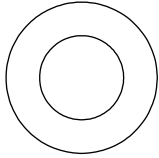

M10 Washer (1)

Inner Box 4

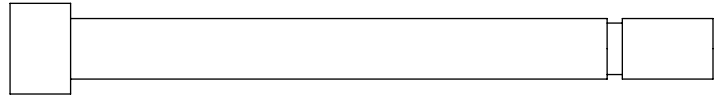

M8 x 85mm Shoulder Bolt (1)

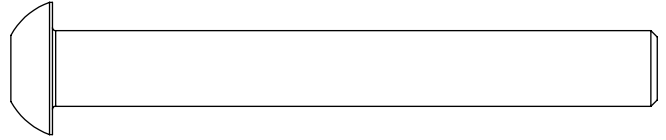

M10 x 80mm SBHCS (1)

Inner Box 5

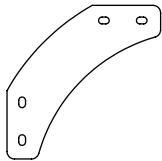

Corner Brace (4)

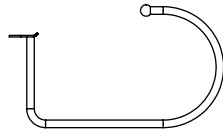

Fabric Hook Holder (5)

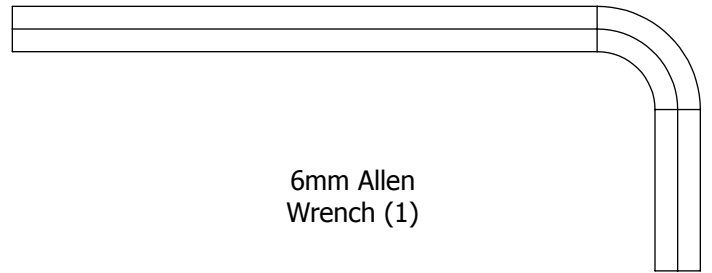

6mm Allen Wrench (1)



5mm Allen Wrench (1)



4mm Allen Wrench (1)



3mm Allen Wrench (1)

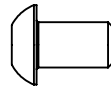

M6 x 10mm SBHCS (4)

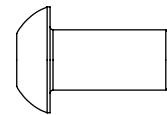

M8 x 16mm SBHCS (25)

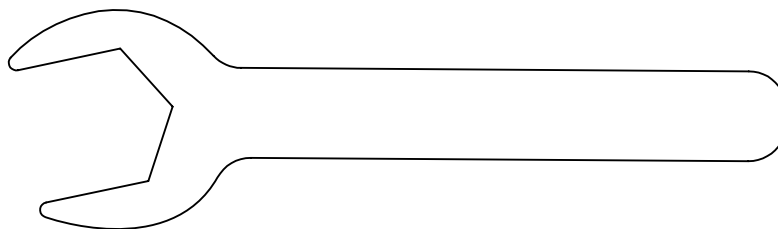

18mm Open End Wrench (1)

Step 1: Table Set Up

Parts Needed:

1. Right Leg (1)
2. Left Leg (1)
3. Table Top (1)
4. M8 x 16mm SBHCS (25)
5. 5mm Allen Wrench (1)
6. 4mm Allen Wrench (1)
7. Corner Brace (4)

1-1 Loosen each Set Screw above each Leveling Foot.

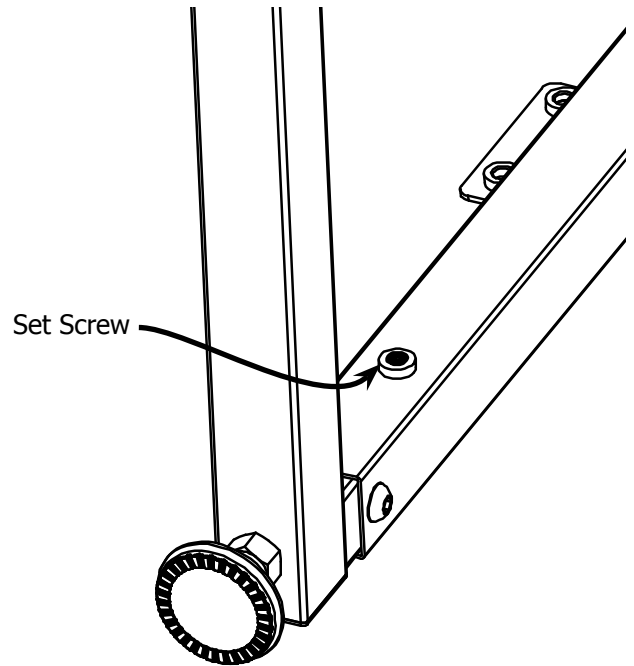

1-2 Remove Height Screws and adjust table height

Note: Loosen the Centering Screws if hard to adjust table height

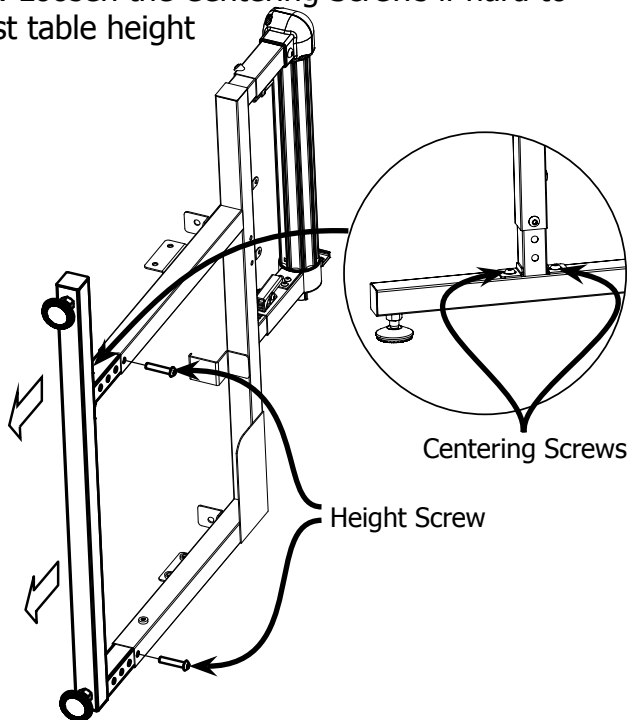

Average sitting height is 4 holes from bottom

1-3 Replace each Height Screw and tighten each Set Screw above each Leveling Foot

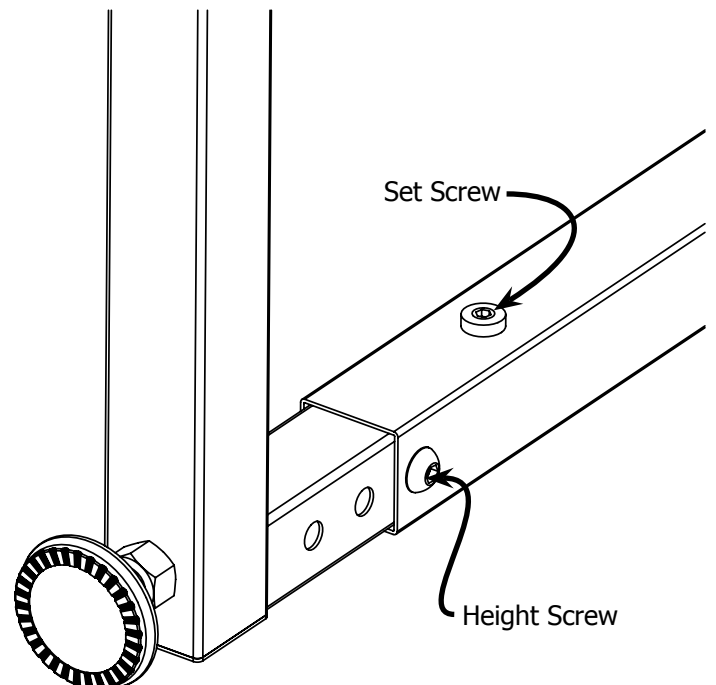

1-4 Attach Hooks to Table

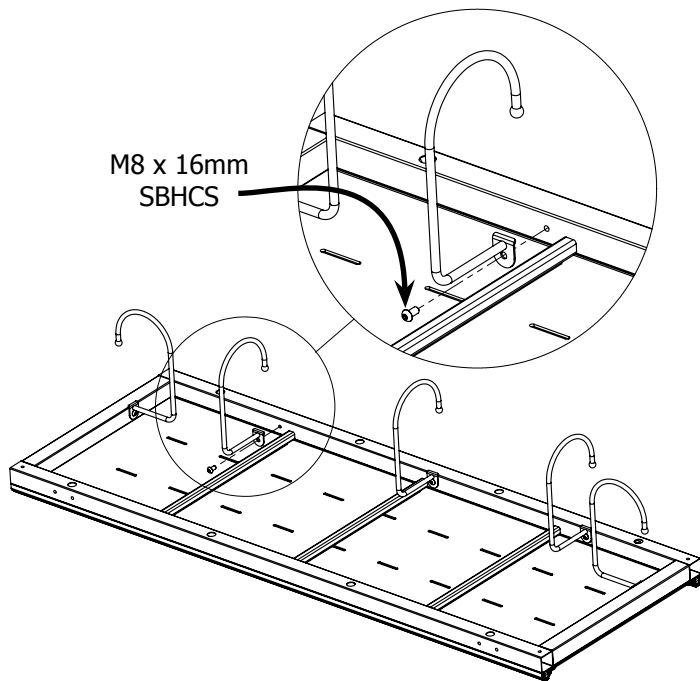

1-5 Attach Legs to Table with the Hooks facing the front of the Legs.

Note: Leave bolts loose, they will be tightened in a further step.

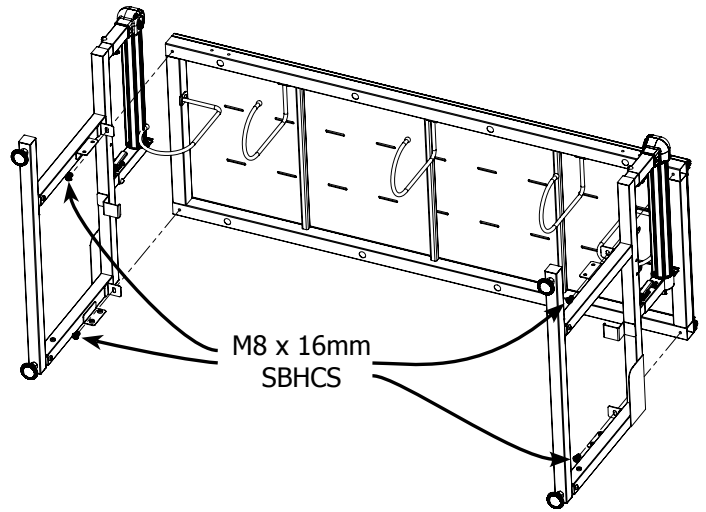

1-6 Tilt Table Upright

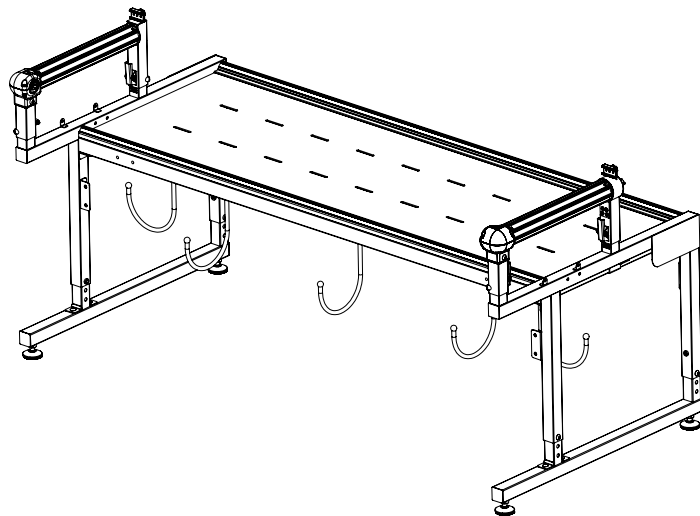

1-7 Attach Corner Braces to each corner

Note: Leave screws loose, they will be tightened in a further step.

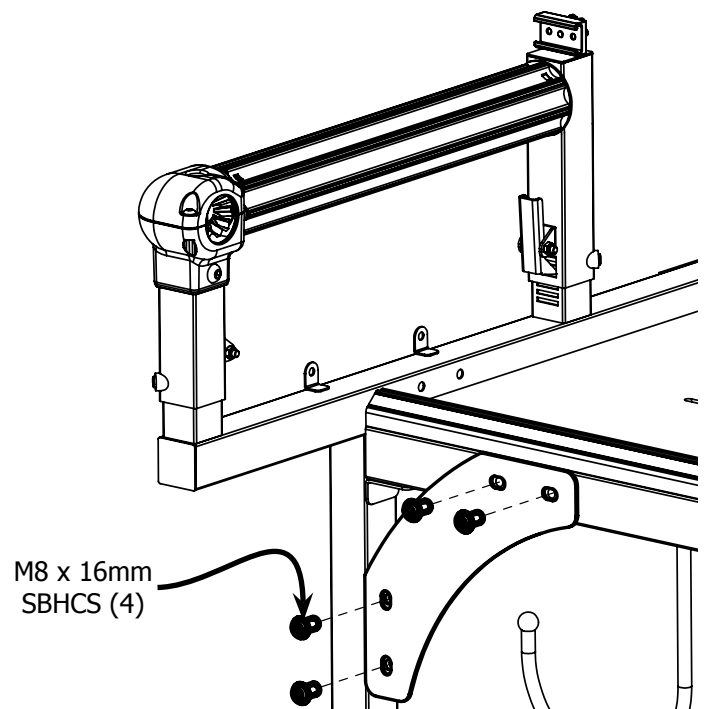

Step 2: Install the Hand Wheel

Parts Needed:

1. 6mm Allen Wrench (1)
2. Large Hand Wheel (1)
3. Long Knob (1)
4. M10 Washer (1)
5. M8 x 85mm Shoulder Bolt (1)
6. M10 x 80mm SBHCS (1)

2-1 Attach the Long Knob

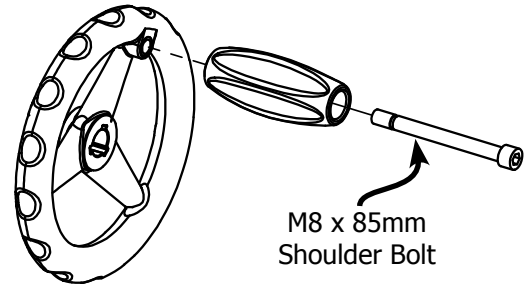

2-2 Attach the Large Hand Wheel

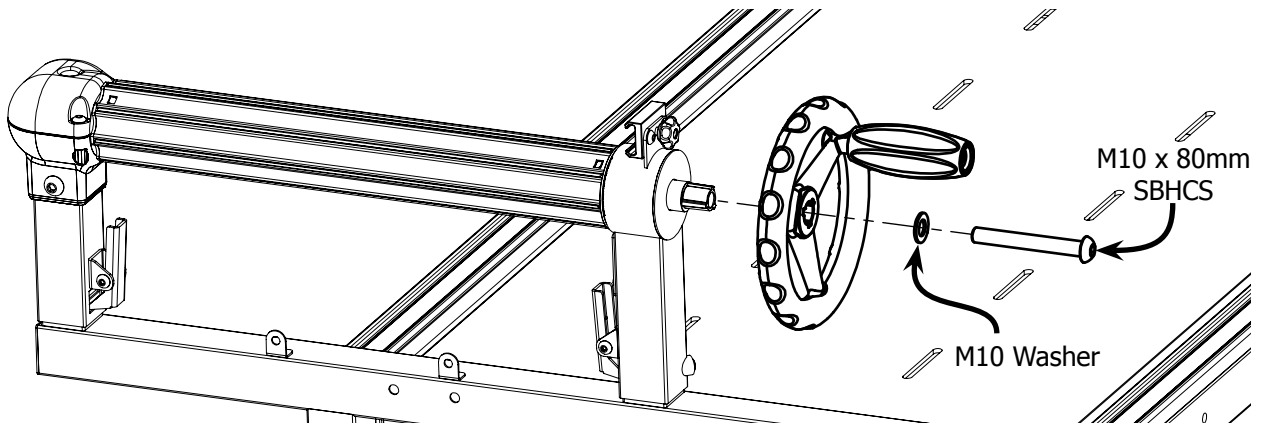

Step 3: Install the Front Rail

Parts Needed:

1. Front Rail (1)
2. 3mm Allen Wrench (1)
3. 5mm Allen Wrench (1)

3-1 Remove Rail End Cap on each Front Corner Post

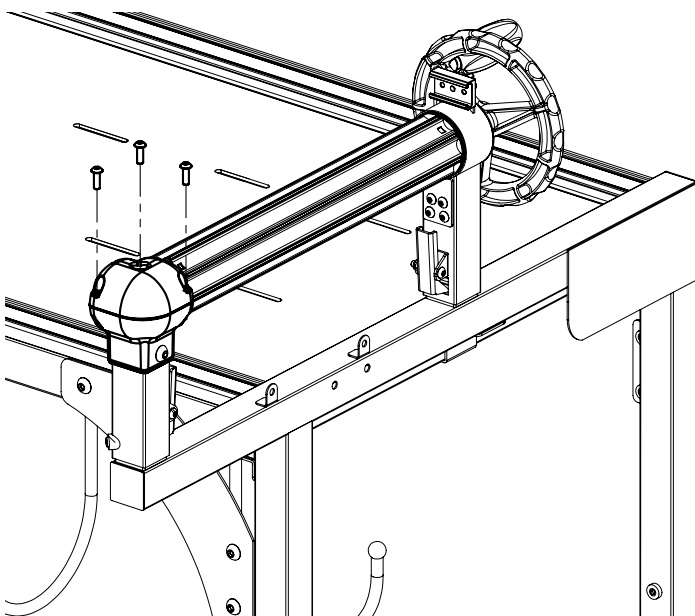

3-2 Insert Front Rail into the right Front Corner Post

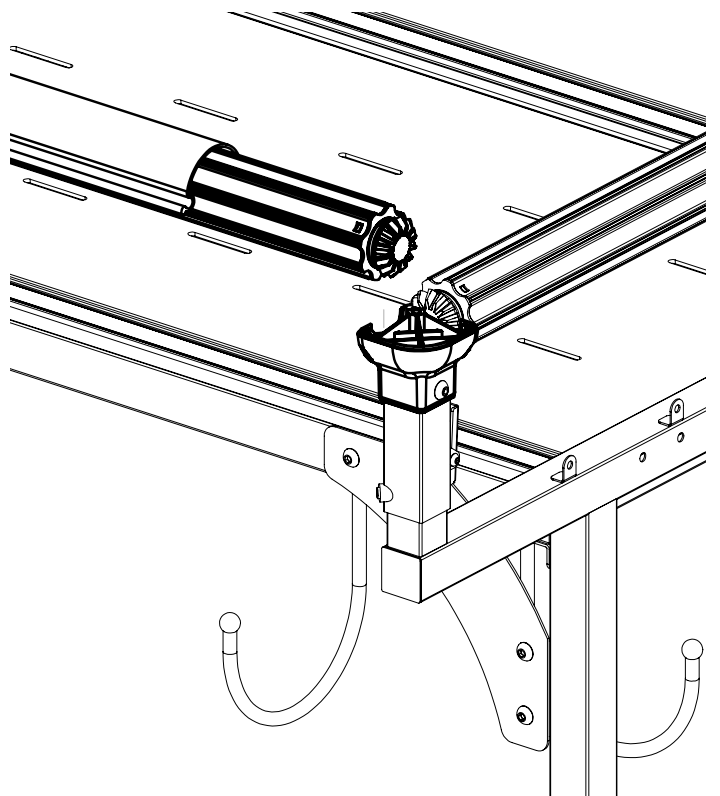

3-3 Re-install Rail End Cap onto the right Front Corner Post

Note: Be sure the side rails and front rail line up so that a long rubber edge on each rail is the highest part of each rail before installing cap.

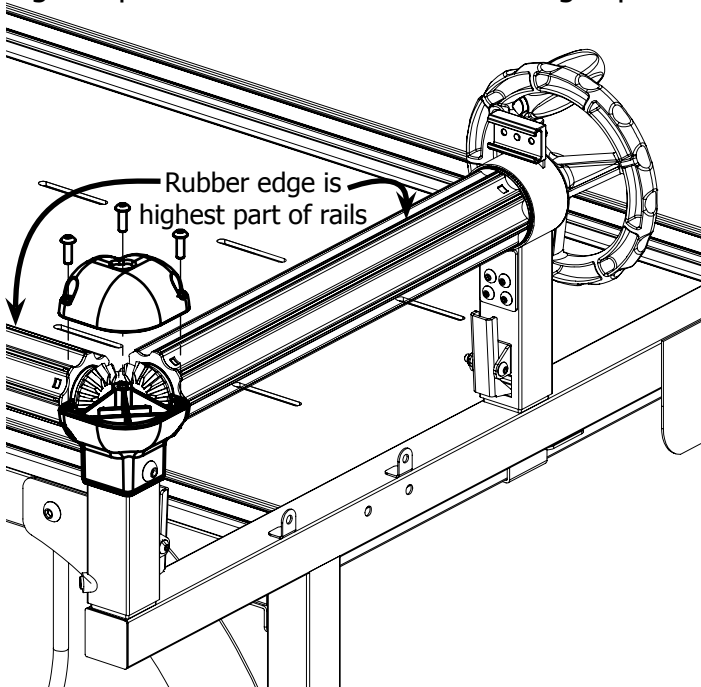

3-4 Tighten each bolt with the Allen Wrench oriented vertically as shown in Fig. 3-4a until difficult to turn, then turn each bolt 1/4 a rotation with the Allen Wrench oriented horizontal as shown in Fig. 3-4b.

Fig. 3-4a

Fig. 3-4b

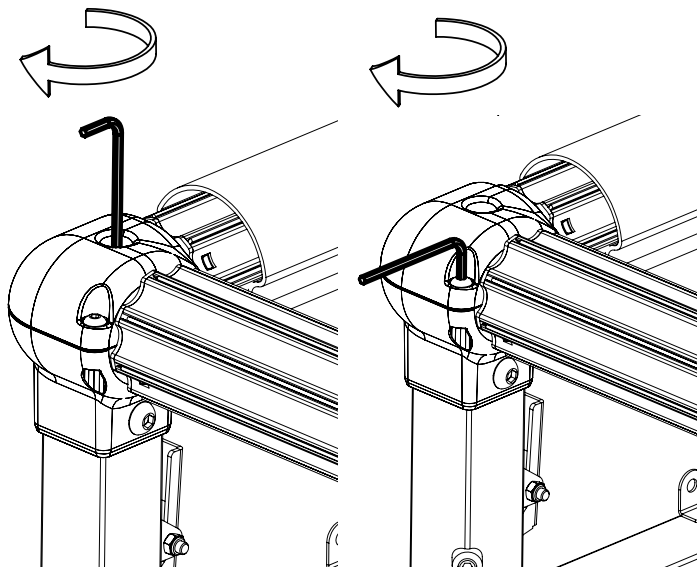

3-5 Insert Front Rail into the left Front Corner Post

You may need to tilt the top of the Leg inward

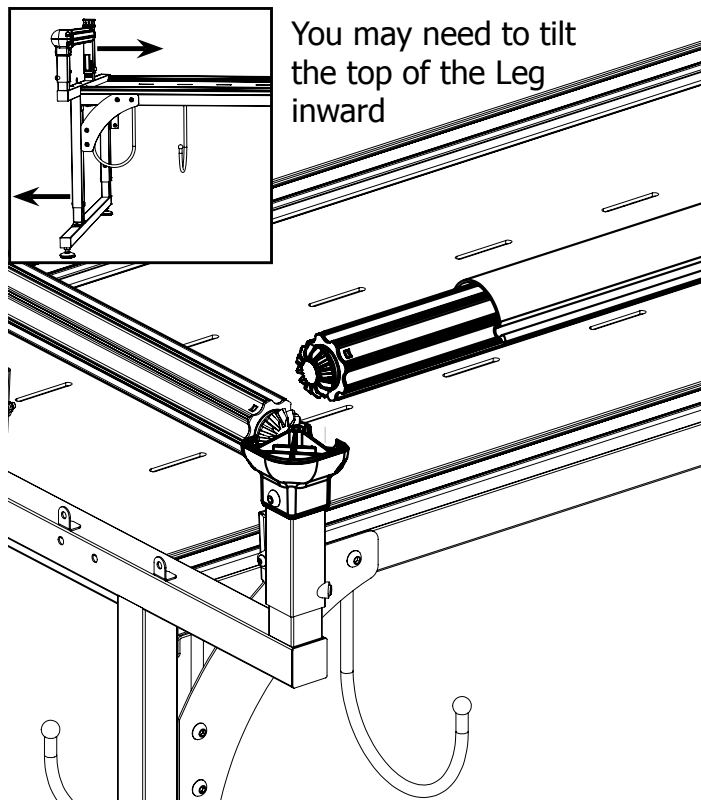

3-6 Re-install Rail End Cap onto the left Front Corner Post

Note: Be sure the side rails and front rail line up so that a long rubber edge on each rail is the highest part of each rail before installing cap.

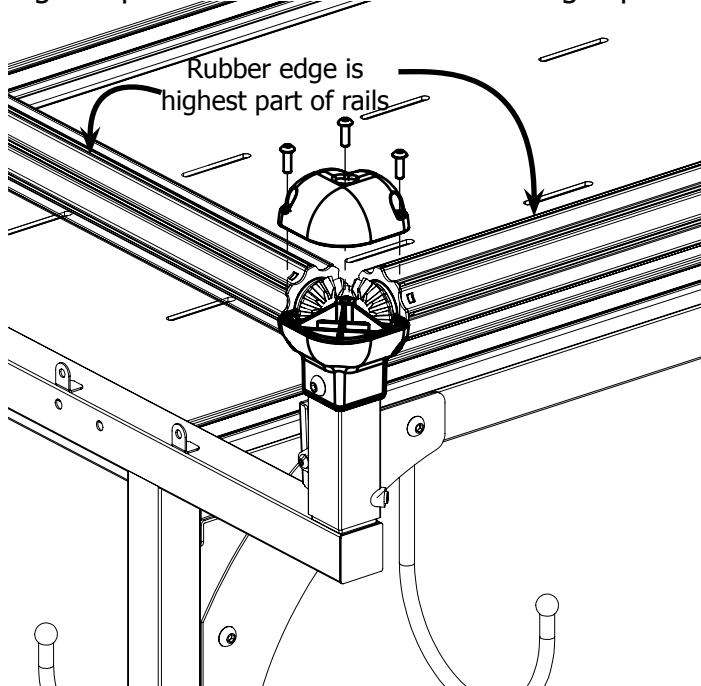

3-7 Tighten each bolt with the Allen Wrench oriented vertically as shown in Fig. 3-7a until difficult to turn, then turn each bolt 1/4 rotation with the Allen Wrench oriented horizontal as shown in Fig. 3-7b.

Fig. 3-7a

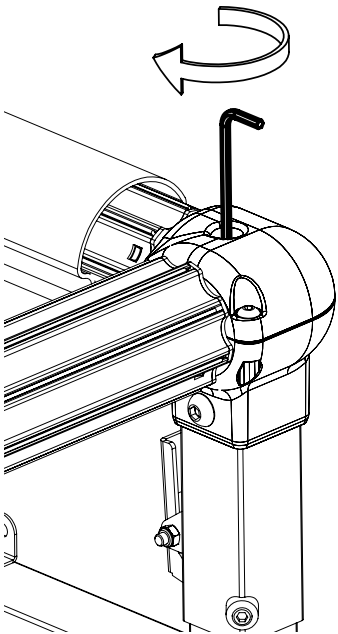
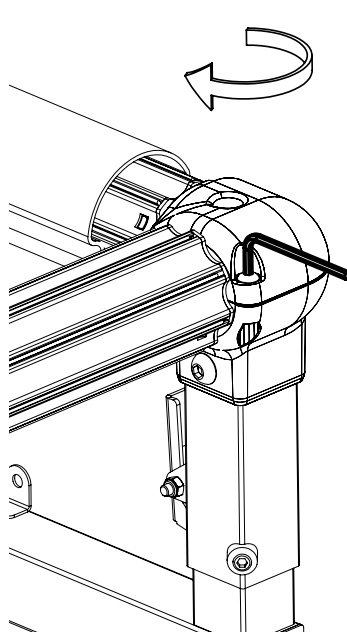
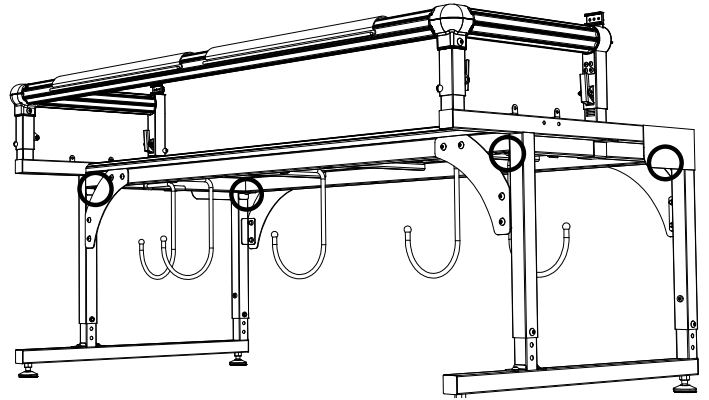

Fig. 3-7b



3-8 Tighten the (4) loose screws on the underside of the table from Step 1-5



3-9 Tighten (8) loose screws on the left side Corner Braces from Step 1-7

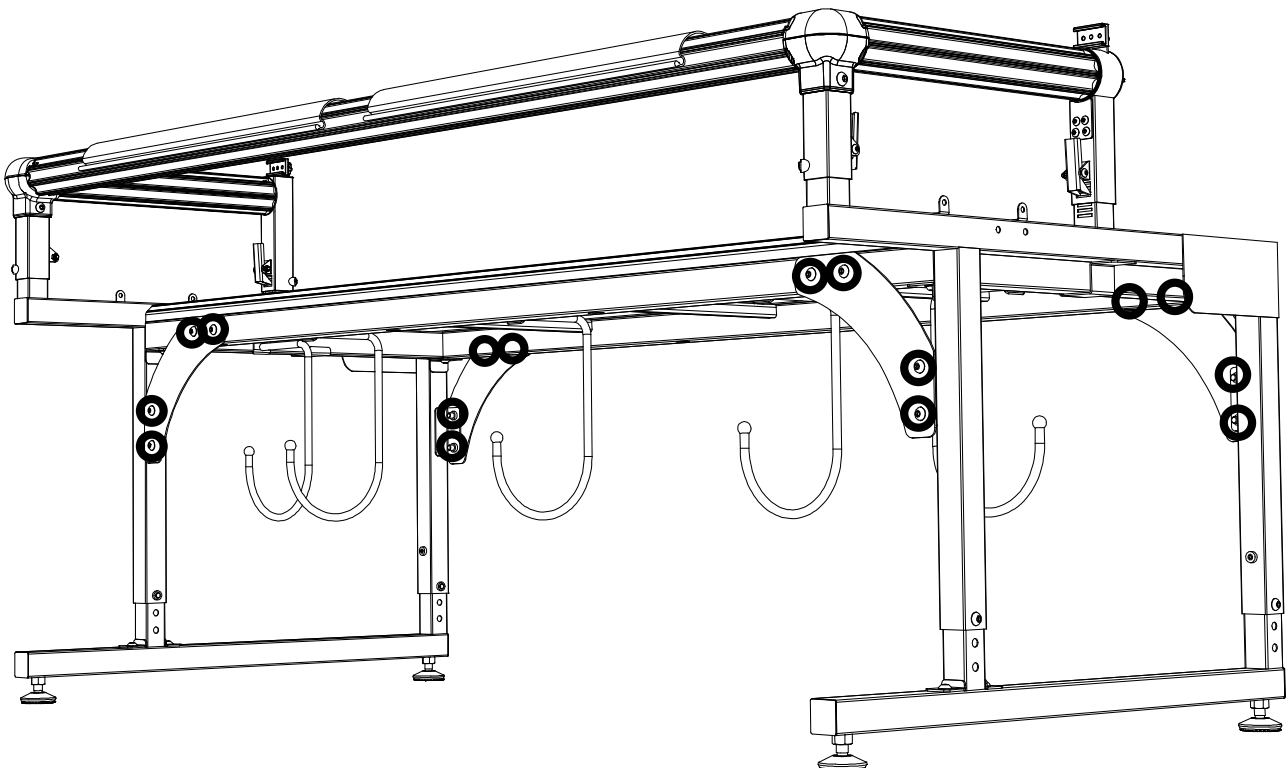

Step 4: Top Plate Assembly

Parts Needed:

1. Right Handle (1)
2. Left Handle (1)
3. Top Plate (1)
4. Handle Crossbar (1)
5. Carriage Bolt and Clamp (1)
6. Bottom Plate (1)
7. M6 x 10mm SBHCS (4)
8. 4mm Allen Wrench (1)

4-1 Attach Handles

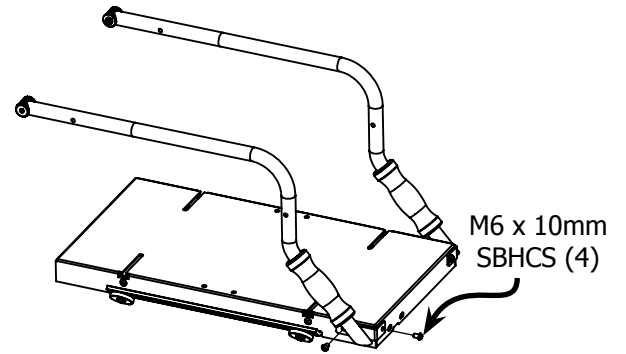

4-2 Un-thread Clamp from Carriage Bolt

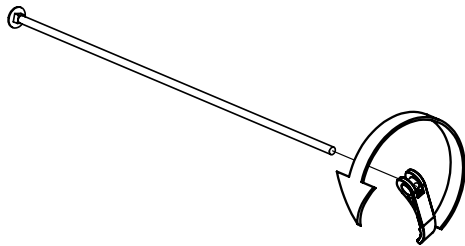

4-3 Assemble Cross Brace with Carriage Bolt and Clamp

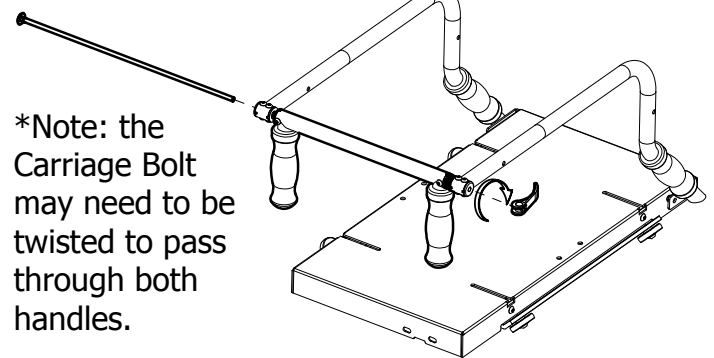

4-4 Place Bottom Plate onto Frame and Top Plate onto Bottom Plate

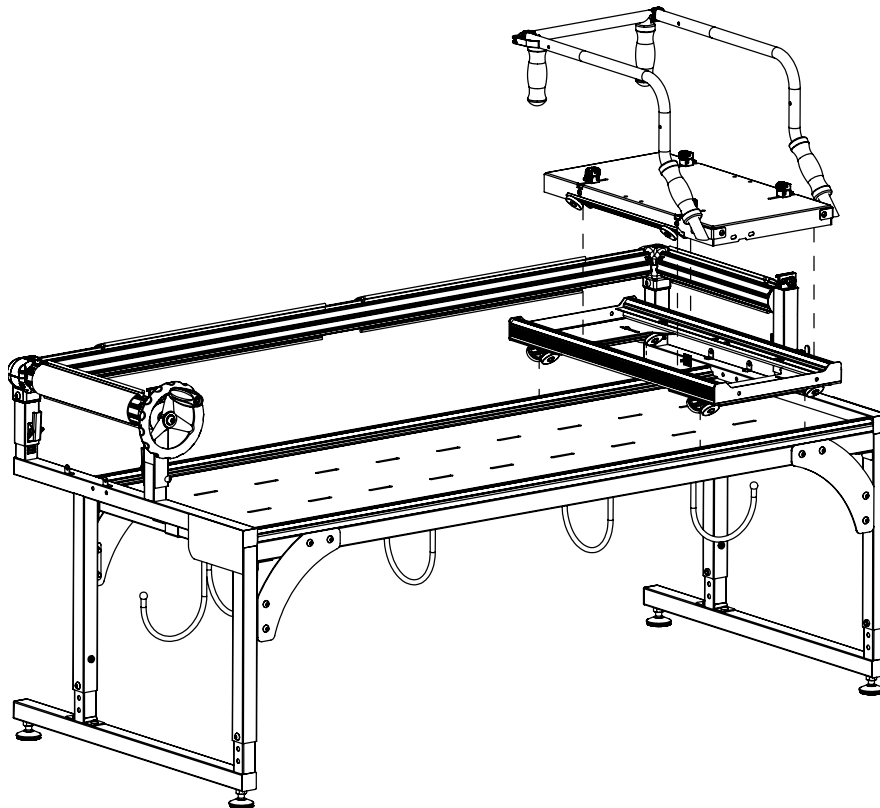

Step 5: Place the Sewing Machine

Parts Needed:

1. Sewing Machine
2. Cam Clamp (4)

5-1 Place Sewing Machine onto Top Plate using the placement instructions below. Slide each Clamp into the grooves on the Top Plate and lock against Machine.

Note: Innovis XV 8500D will not use the Front 2 Clamps.

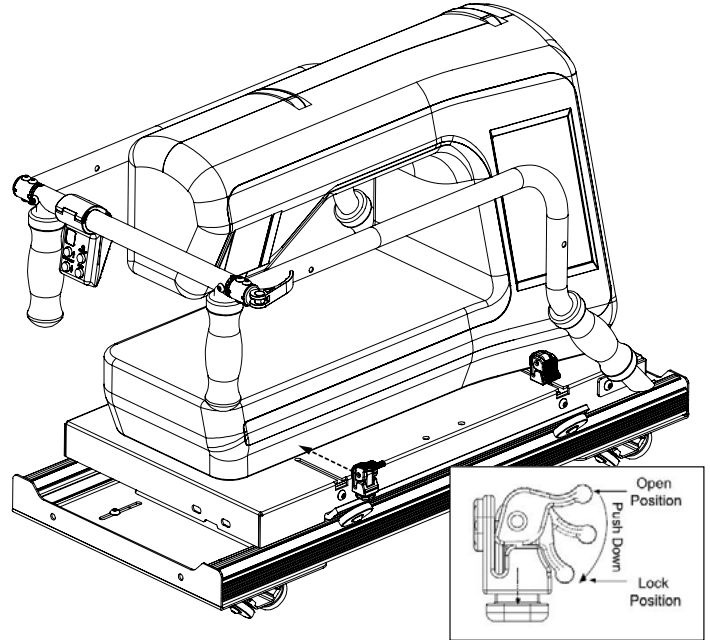

Placement Instructions:

Innovis VQ 2400; Innovis XV 8500D:

Center from side to side. Align the back of the throat with the verticle handlebar

Brother 1500:

Center from front to back and from side to side.

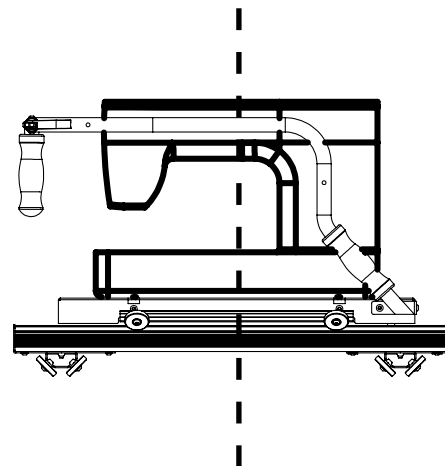
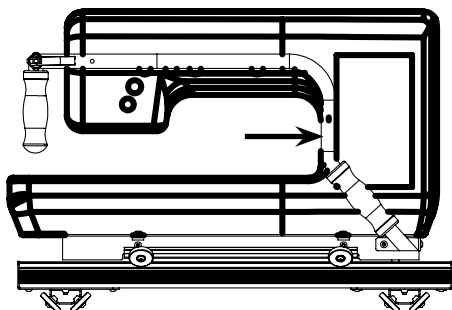
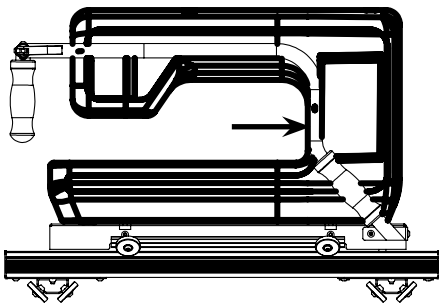

Step 6: Install the Back Rail

Parts Needed:

1. Back Rail (1)
2. 4mm Allen Wrench (1)

6-1 Loosen the Set Screws on each Corner Post

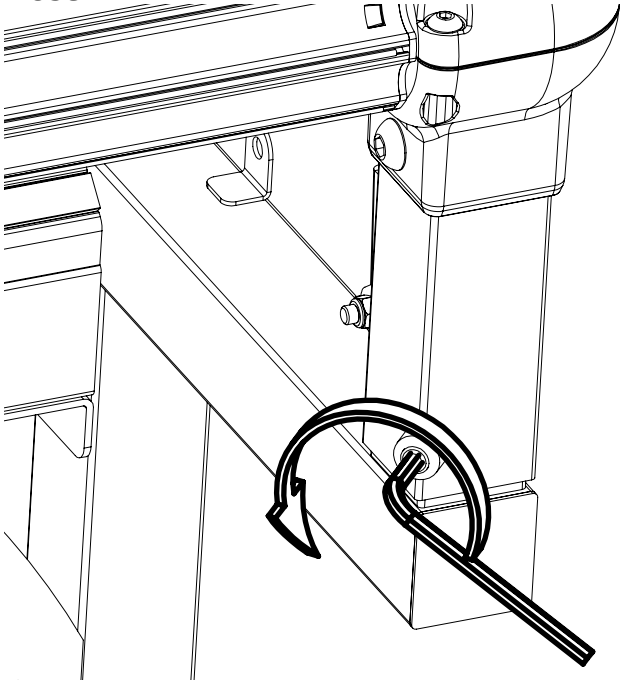

6-3 Loosen each Knob on the back of each Rail Holder

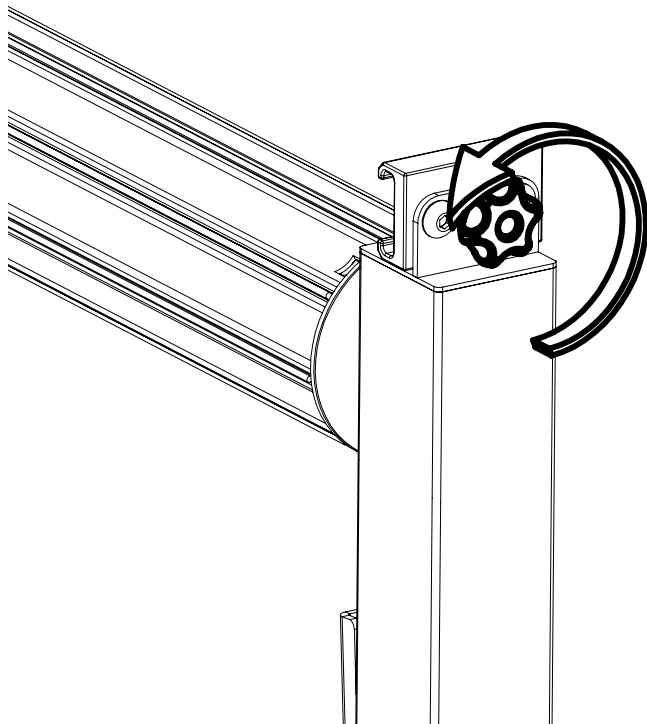

6-2 Raise Rails 16 slots upward

Note: You may need to pull rails upward to allow the levers to be pressed in.

Final height will be adjusted in later step.

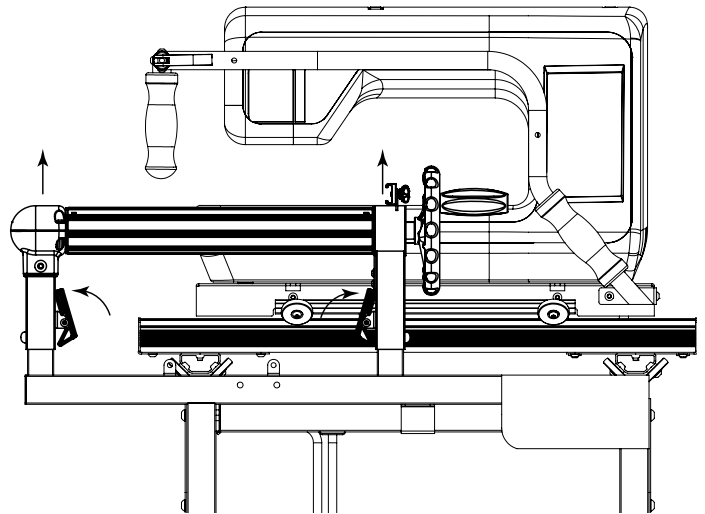

6-4 Insert Back Rail through the throat of the Sewing Machine

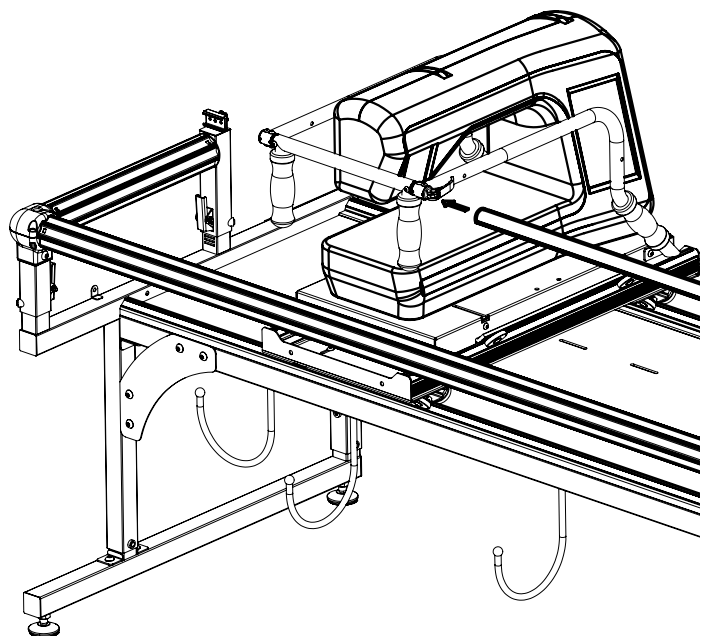

6-5 Insert the left end of the Back Rail into the left back Rail Holder

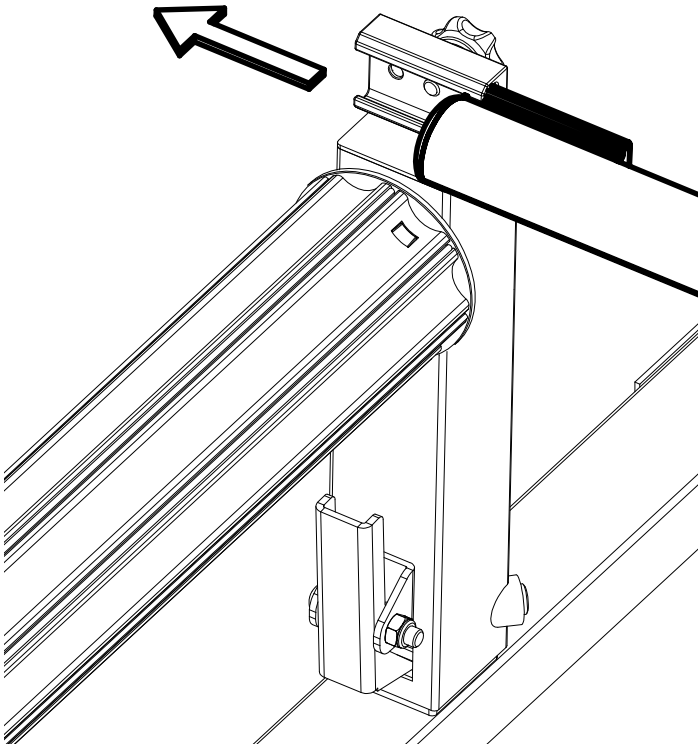

6-6 Insert the right end of the Back Rail into the right back Rail Holder

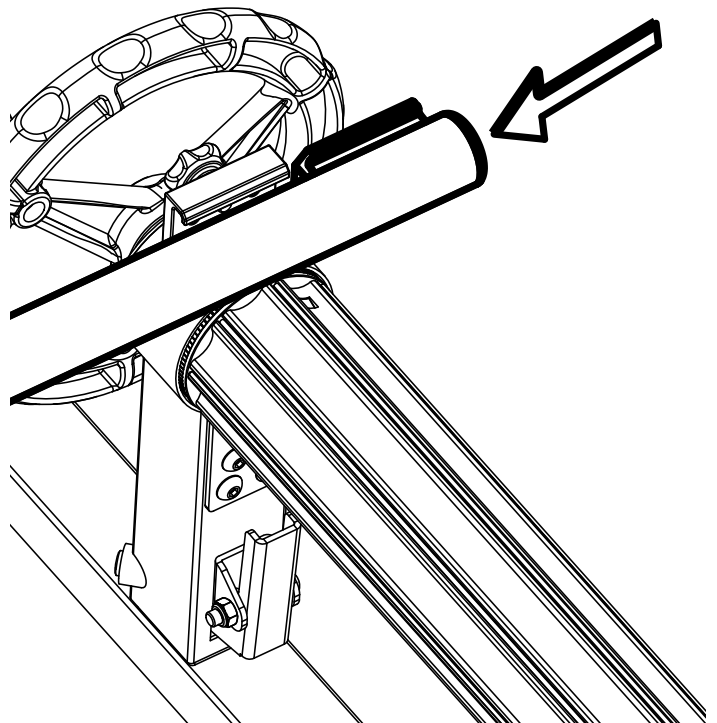

6-7 Tighten each Knob on the back of each Rail Holder

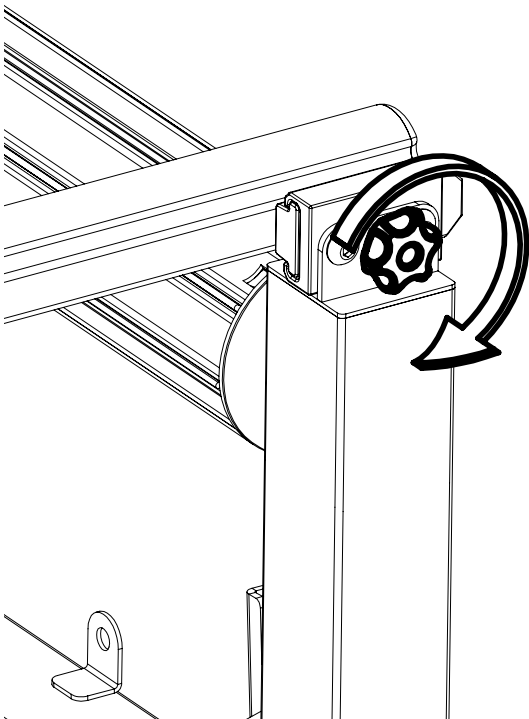

6-8 Adjust leveling feet height until table is level with the (1) 18mm Open End Wrench

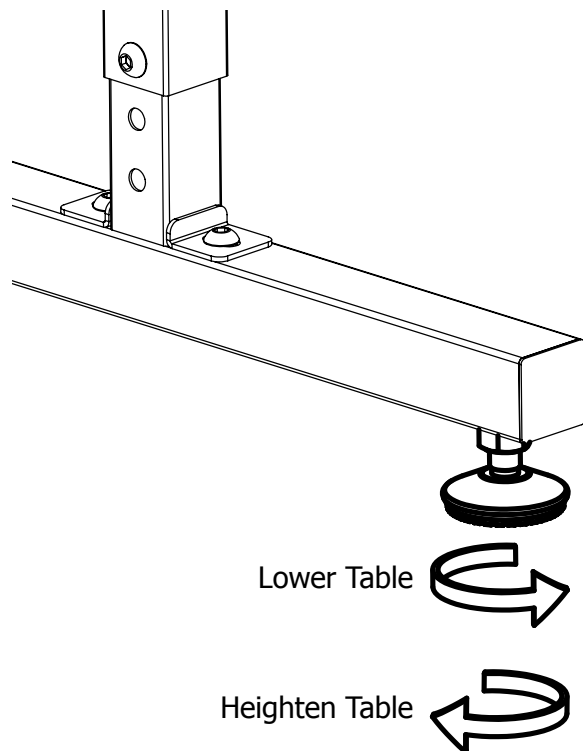

Step 7: Adjust Fabric Height

Parts Needed:

1. 4mm Allen Wrench (1)

7-1 Move Back Rail 1/4" above Machine

Note: refer to step 6-2 for instructions on how to raise and lower the rails.

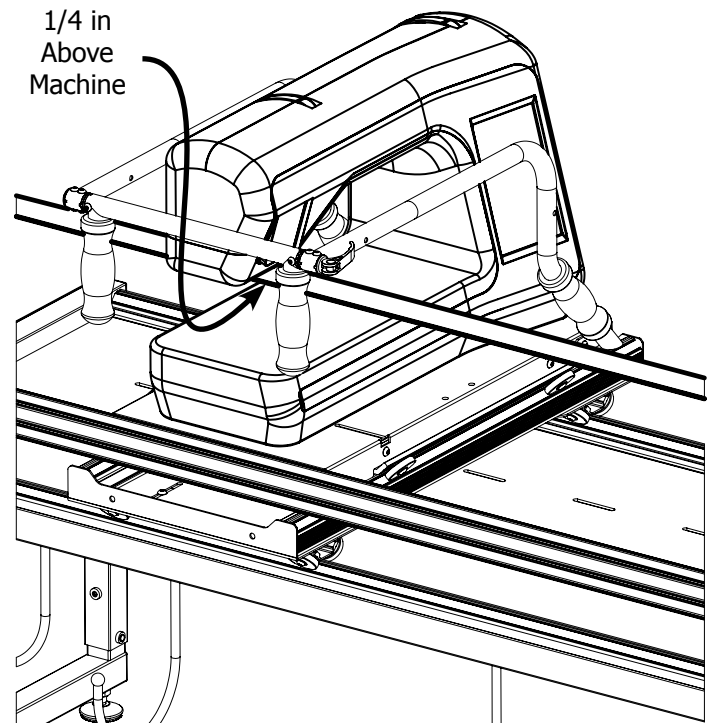

7-2 Tighten set screws in Rail Holders

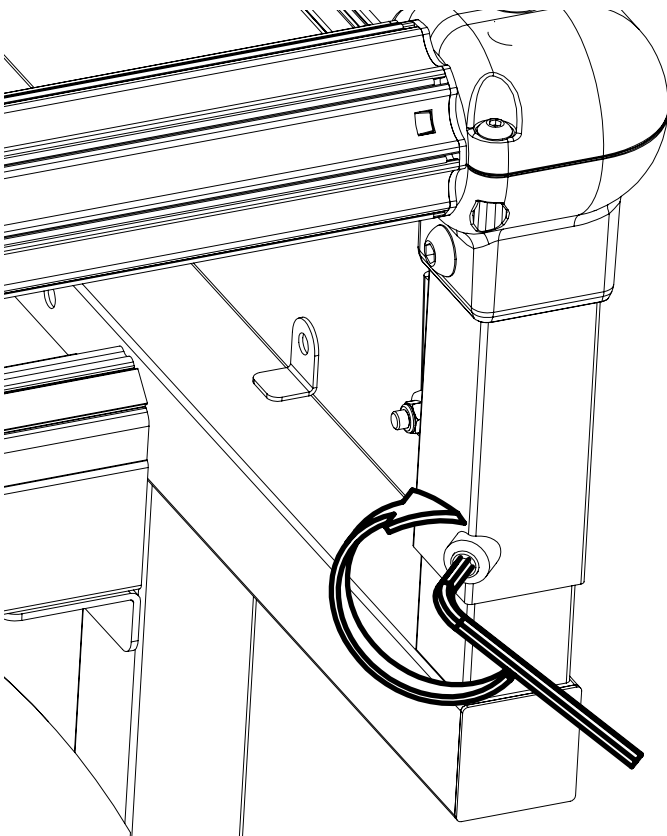

7-3 Move the Sewing Machine so that the Needle is 1" away from the Back Rail. Hold the Machine in place as you adjust the Carriage Stop by loosening the knob and sliding the Sewing Machine stop against the back wheel. This will be adjusted again in the Fabric Installation instructions.

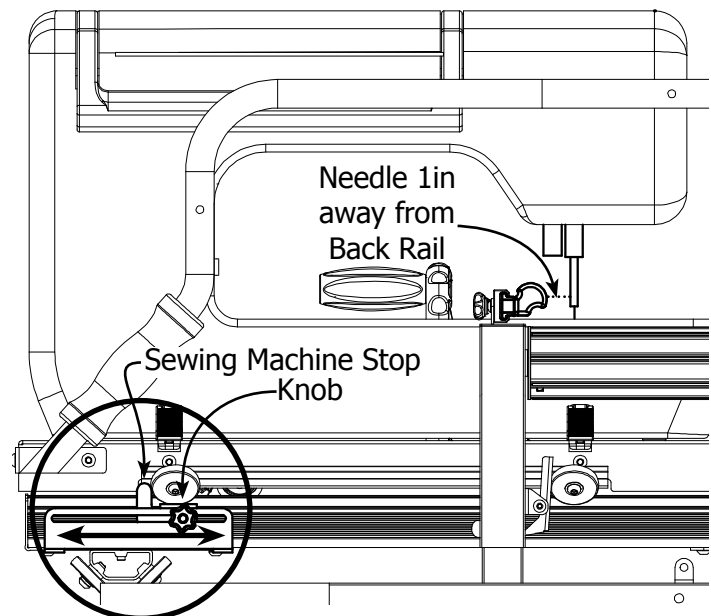

Step 8: Control Box Set-up

Parts Needed:

1. Control box

8-1 Open the Control Box

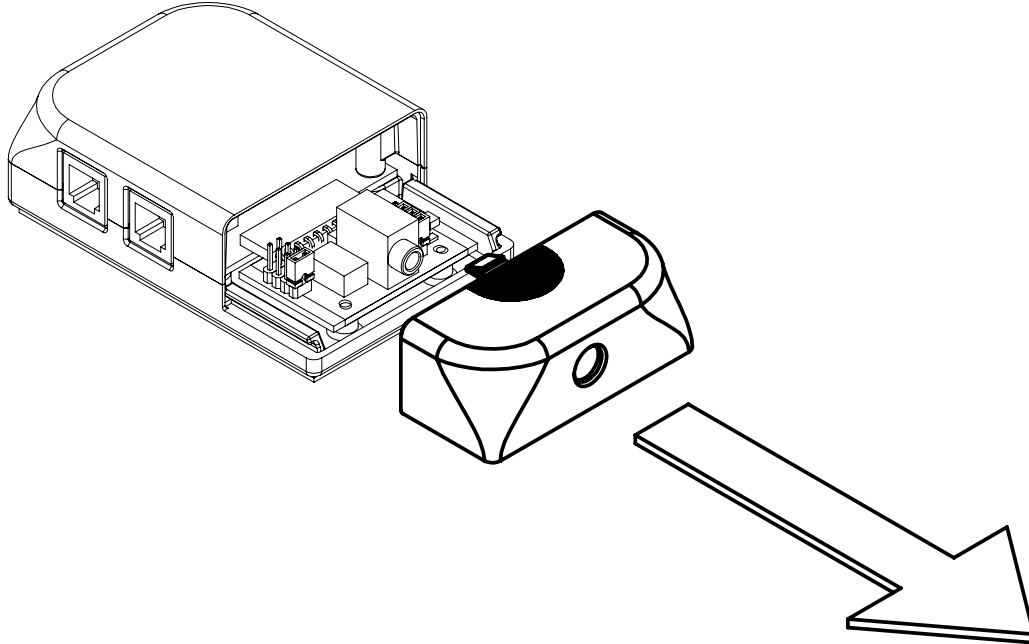

8-2 Move the Control Jumpers to the correct pins based on your Machine Model.

Brother 1500S:

*Innovis 1500D,
Innovis 2500D,
Innovis 4500D:*

*Innovis VQ2400,
Innovis VM6200,
Innovis XV8500D:*

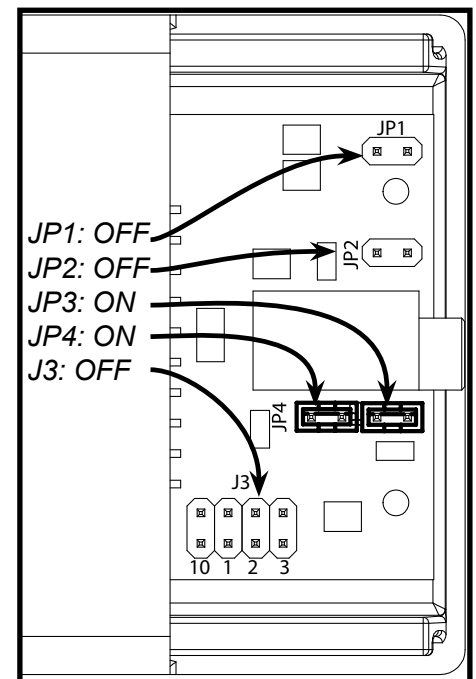
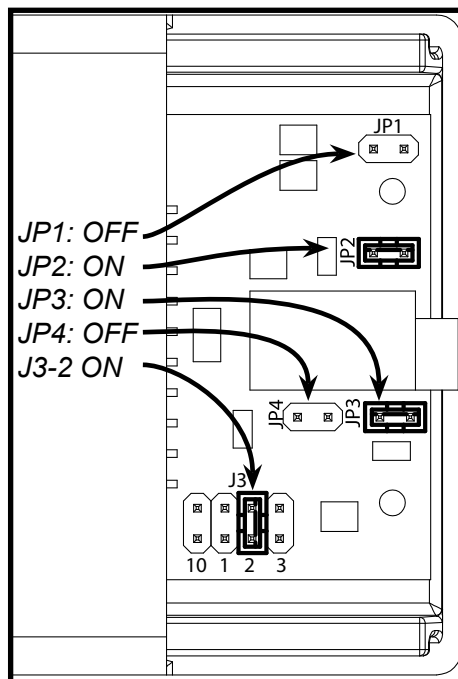
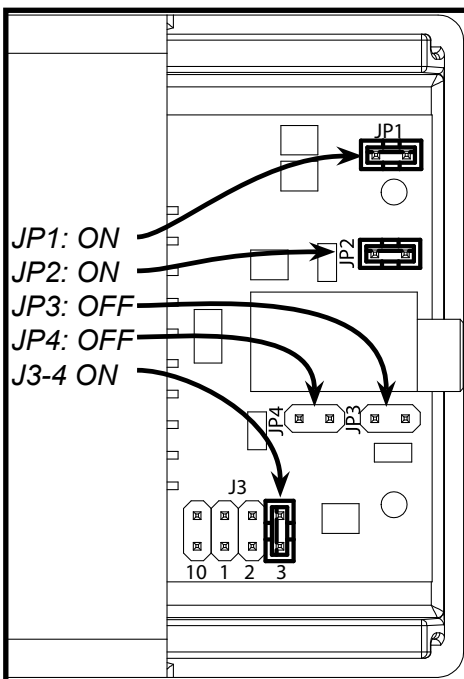

Step 9: Sure Stitch Installation

Parts Needed:

1. Display Box (1)
2. Control Box (1)
3. Sure Stitch Display Cable (1)
4. Sewing Machine Cable (1)
5. Power Supply (1)
6. Encoder with Encoder Cable(2)
7. Velcro Strap (6)
8. Zip Tie (8)
9. Zip Tie Mount (6)
10. M4 x 16mm SBHCS (1)
11. M6 x 20mm SBHCS (2)
12. 4mm Allen Wrench (1)
13. 2.5mm Allen Wrench (1)

9-1 Remove (1) M4 x 16mm SBHCS from Display Box

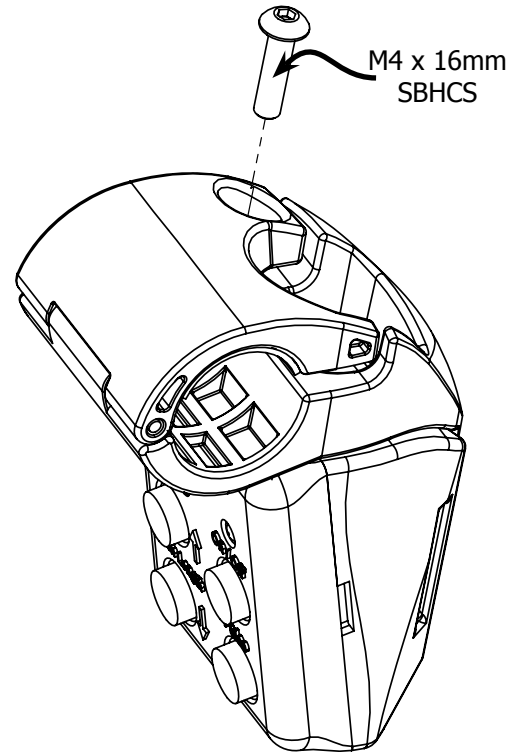

9-2 Clamp Display Box onto Crossbar next to the Handle on the Left or Right Side

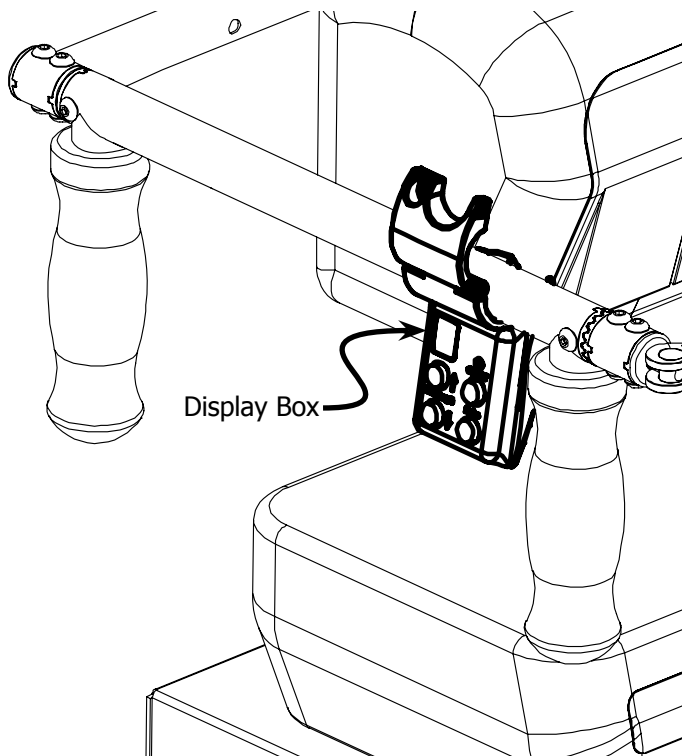

9-3 Secure the Display Box with (1) M4 x 16mm SBHCS

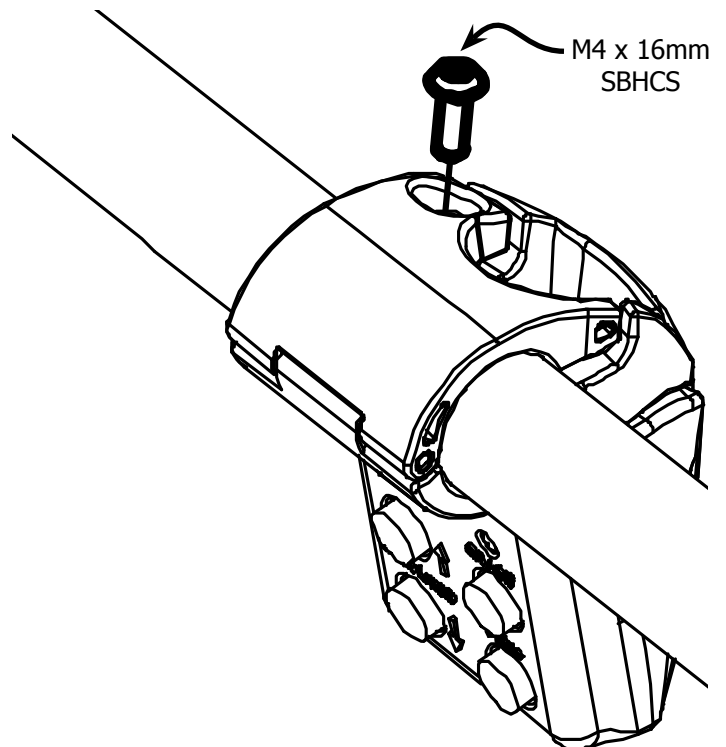

9-4 Remove Sticky Tape Paper Backing from Control Box

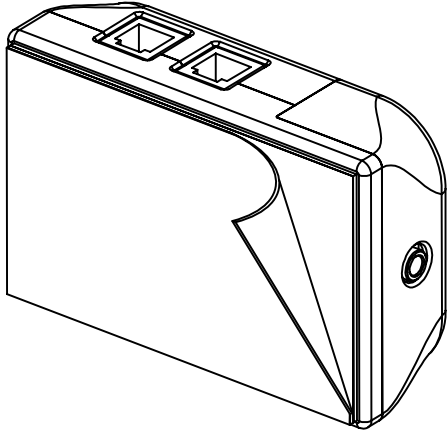

9-5 Place Control Box on back of Machine

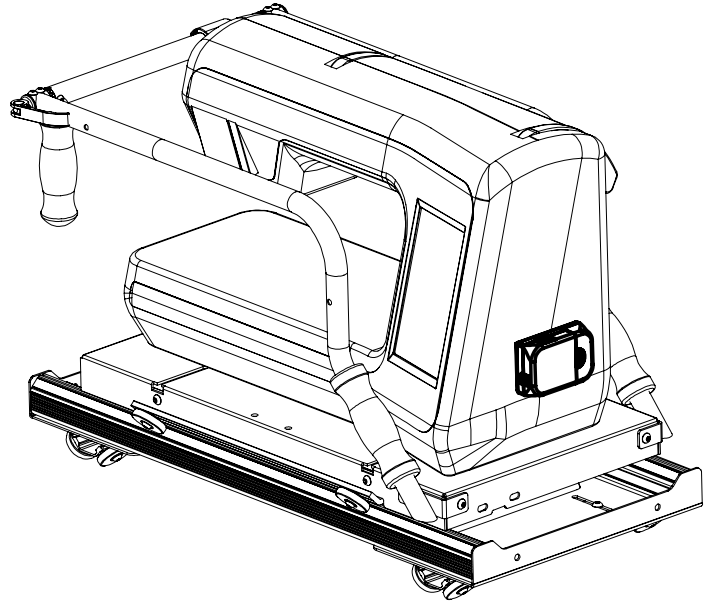

9-6 Plug in one end of the Display Cable into the Display Box

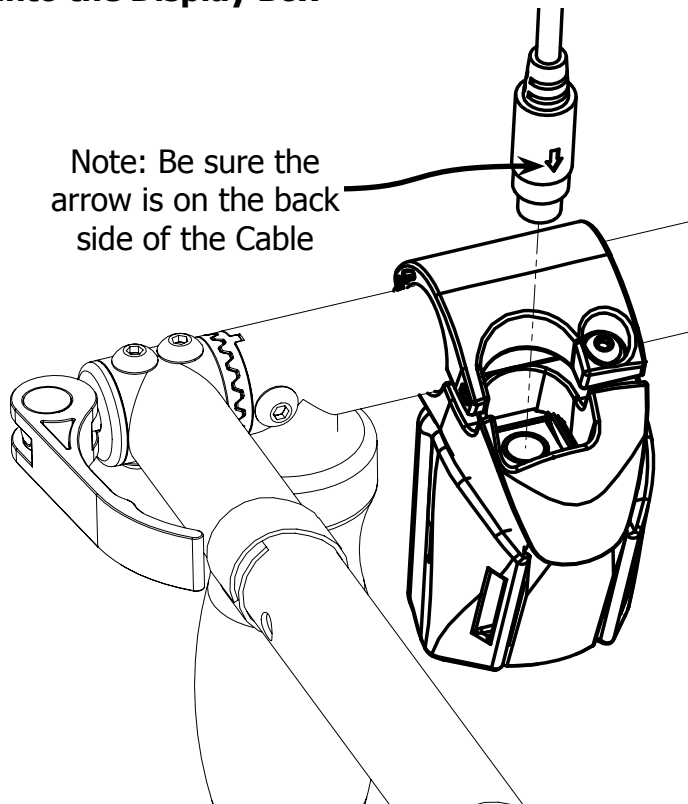

9-7 Plug in the other end of the Display Cable into the Control Box

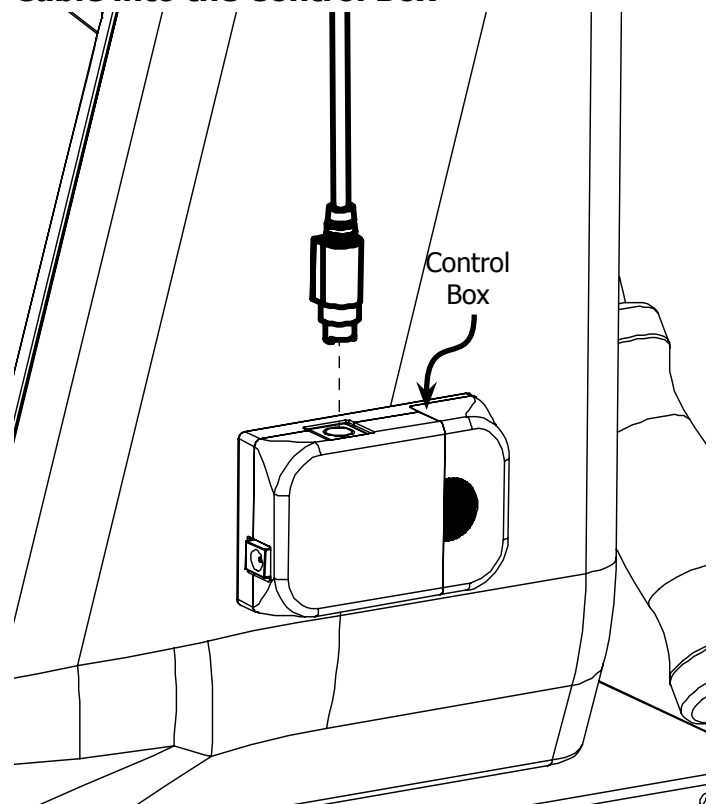

9-8 Use the Velcro Straps to Secure Display Cable

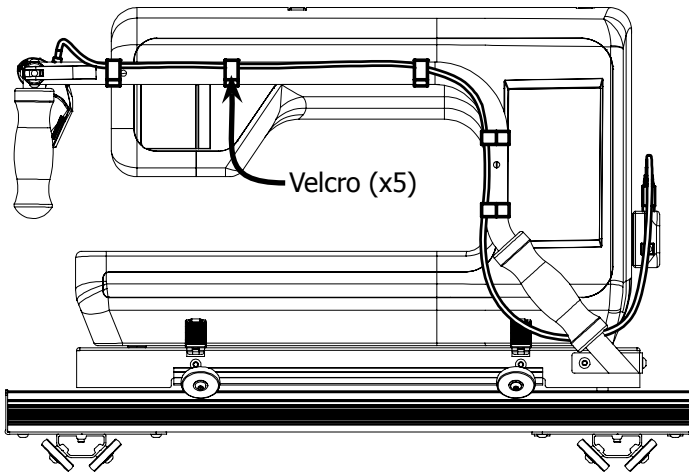

9-9 Remove Back Right Wheel and Screw from Top Plate

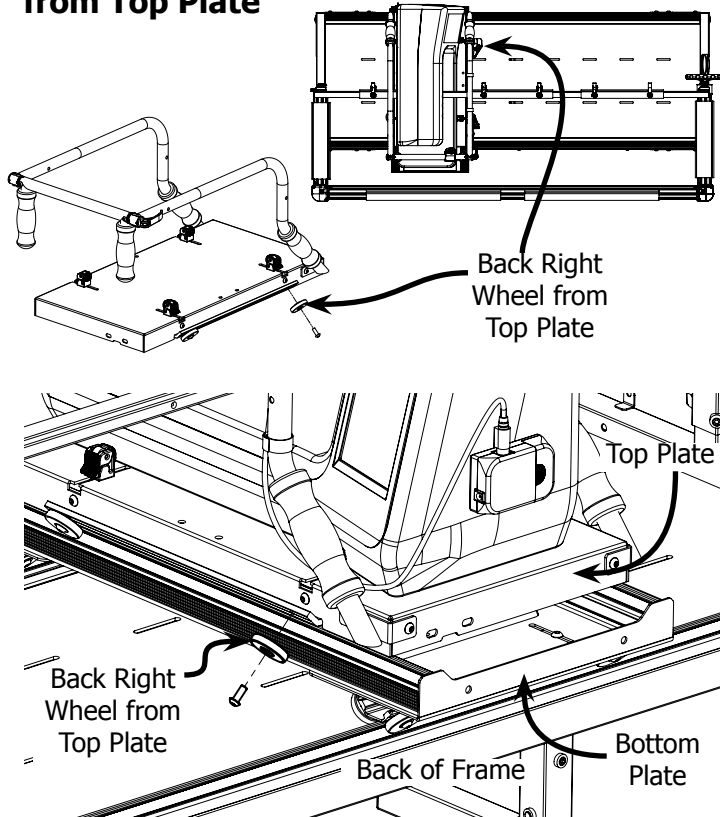

9-10 Install Encoder to Top Plate with M6 x 20mm SBHCS and Removed Wheel

Note: Rotate Encoder until the Encoder Spring is partially compressed and then tighten the M6 X 20mm SBHCS for better accuracy.

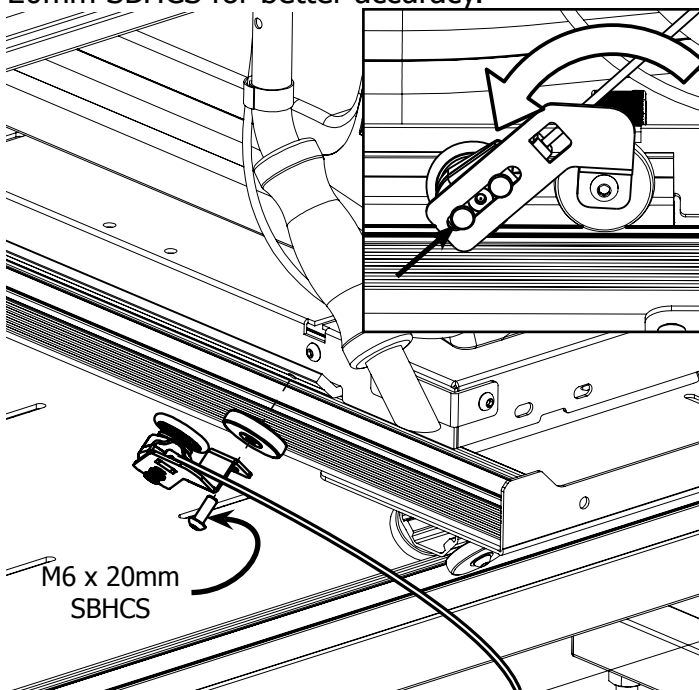

9-11 Remove Back Left Wheel and Screw from Bottom Plate

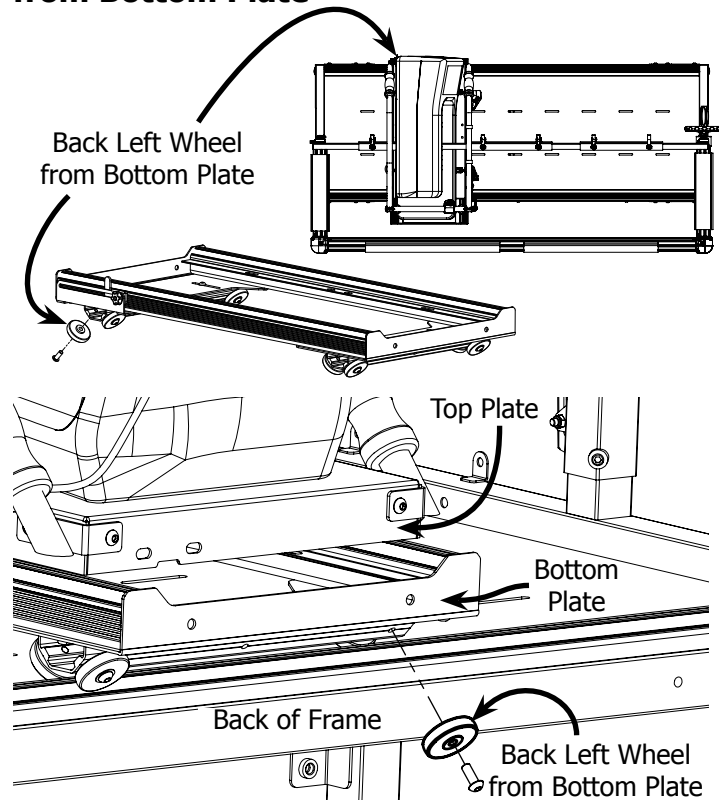

9-12 Install Encoder to Bottom Plate with M6 x 20mm SBHCS and Removed Wheel

Note: Rotate Encoder until the Encoder Spring is partially compressed and then tighten the M6 X 20mm SBHCS for better accuracy.

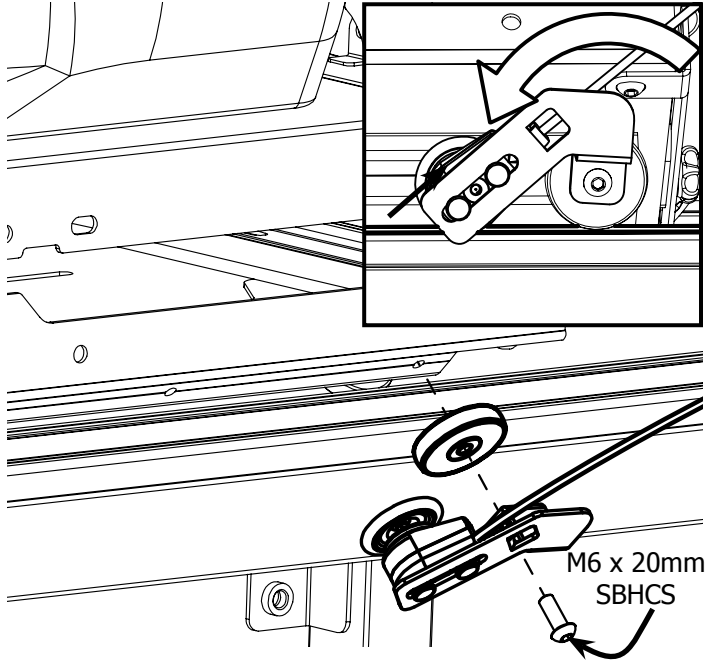

9-13 Plug Encoder Cables into Control Box

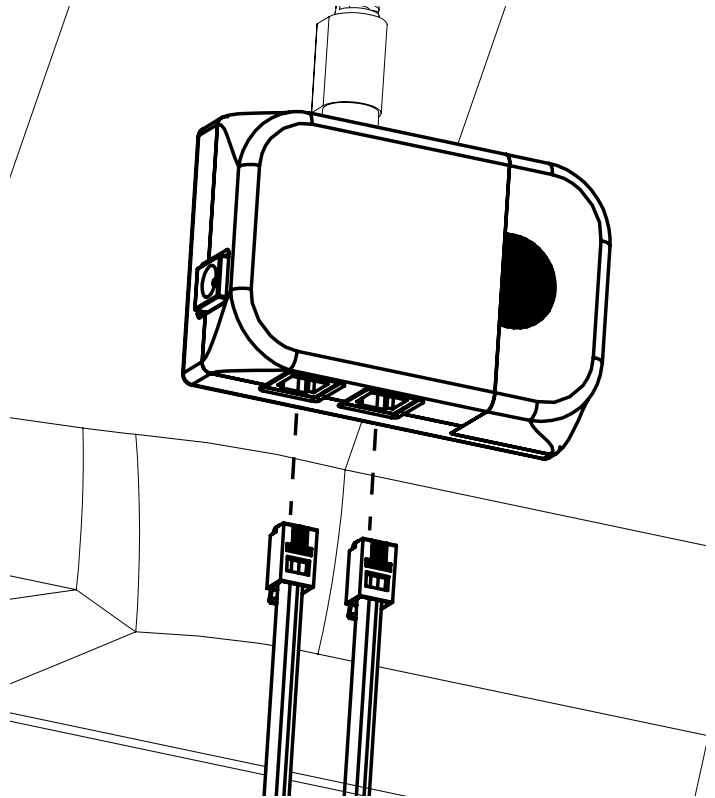

9-14 Plug in Power Supply to Control Box

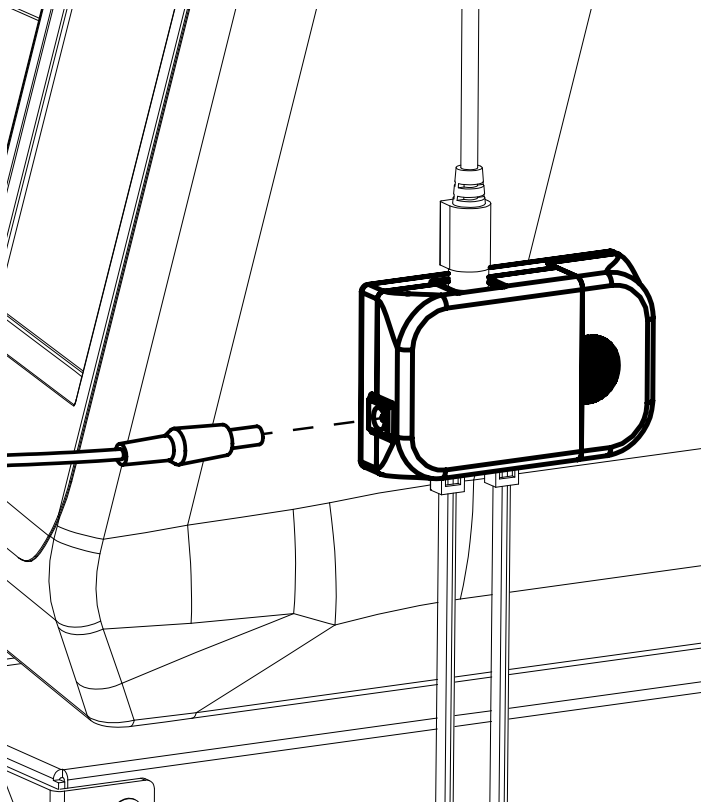

9-15 Plug Power Supply to an outlet.

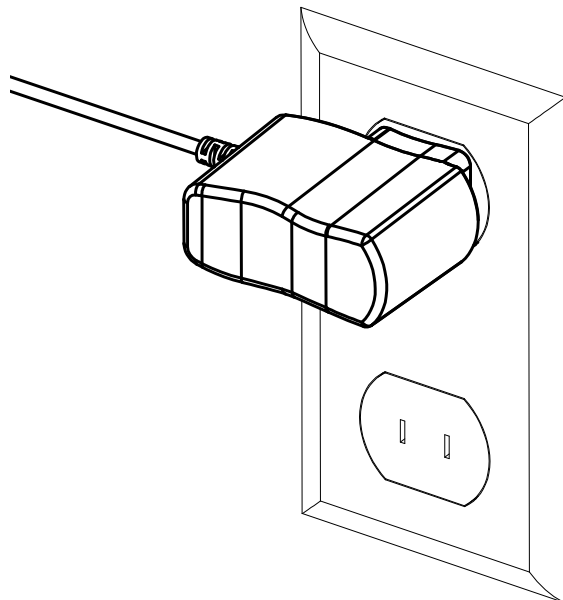

9-16 Plug Sewing Machine Cable into Control Box

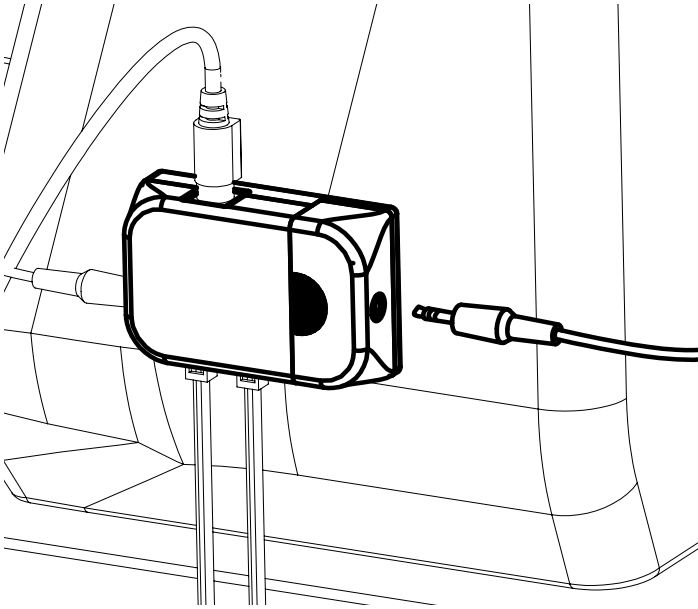

9-17 Plug Sewing Machine Cable into the Foot Pedal Port on your Sewing Machine

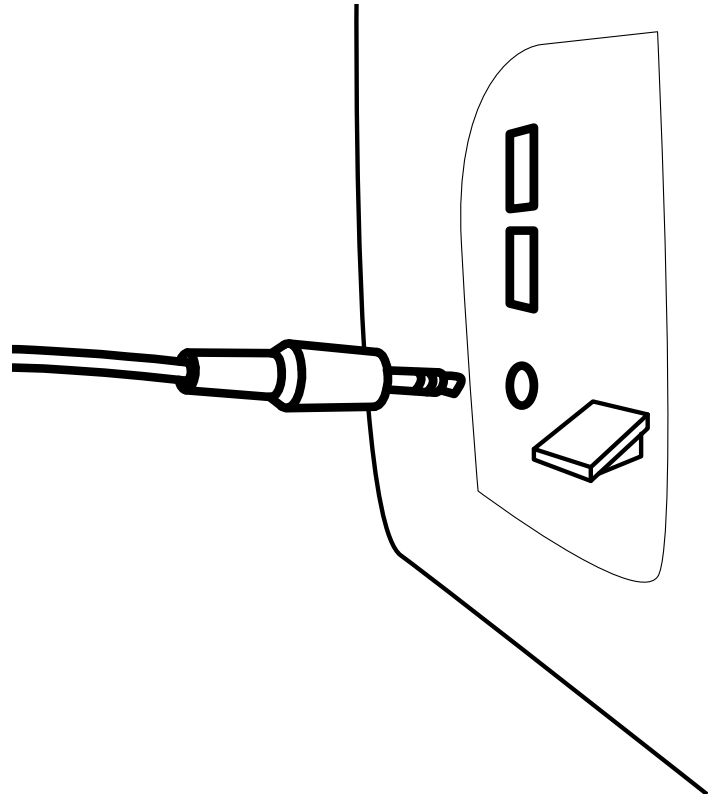

9-18 Secure Sewing Machine Cable and Power Supply Cable away from the Track and Wheels with the Zip Ties and Zip Tie Mounts. Be sure to leave enough slack in the cables to allow the machine to roll completely forward and backwards on the Bottom Plate.

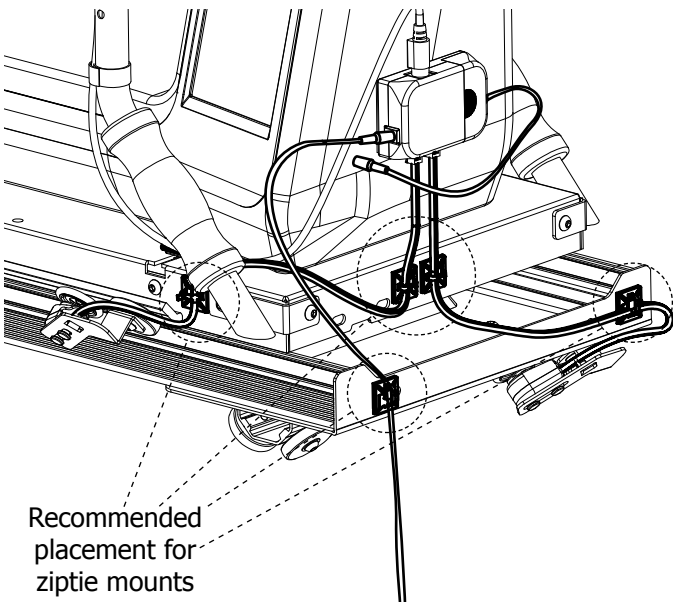

Recommended placement for zip tie mounts

9-19 If your machine has a sewing speed switch, set it to it's highest setting

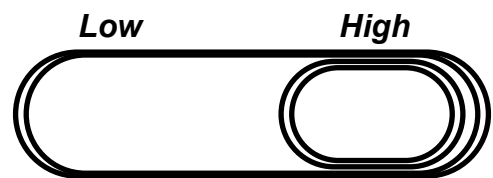

9-20 Sewing Machine Controls

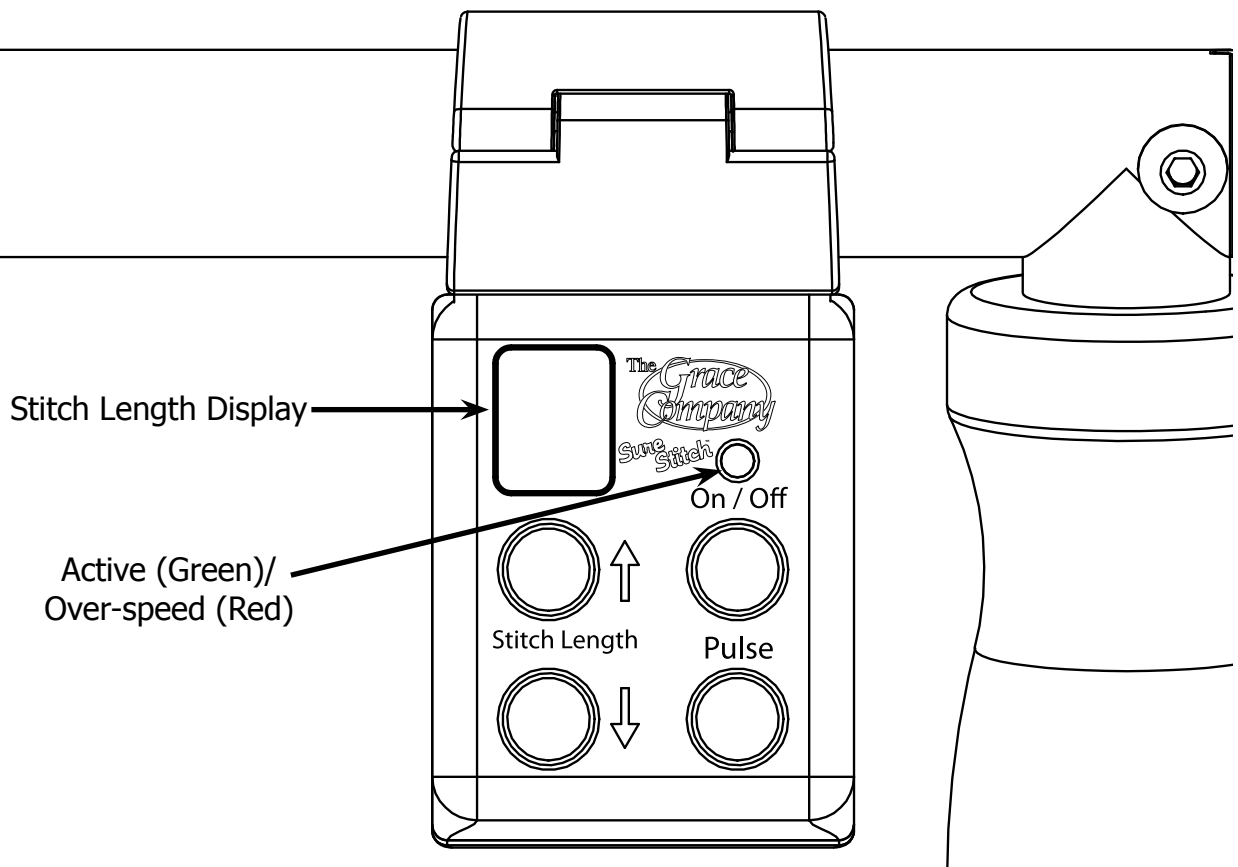

Note: When the SureStitch is in the "on" mode, the sewing machine WILL BEGIN TO STITCH! When you stop moving the machine, it will continue to stitch at the sewing machine's minimum speed until you press the off button. This feature ensures the machine will maintain as consistent a stitch length as possible with the initial movement of the machine.

On/Off Button: The On/Off button activates/disables the regulated stitch feature of the SureStitch. When the regulated stitch is active, the green LED light directly above the button will be lit. In regulated mode, your sewing machine will automatically adjust the speed that it stitches based on how fast you move your sewing machine around on the quilting frame. If you move your sewing machine too fast, it will reach its maximum stitch speed, and no longer be able to stitch fast enough to keep a constant stitch size. The green LED above the On/Off button will turn red when your sewing machine has reached its maximum stitch speed. When the LED above the On/Off button is lit red, your stitches will be longer than your set size.

Pulse Button: When pressed and released quickly a single stitch occurs. Cut the thread by pressing and holding the Pulse Button until a beep is heard.

Stitch Length Buttons: Use the Stitch Length buttons to adjust how long your stitches will be while using the regulated stitch mode. The LED display directly above the Stitch Length buttons displays your current Stitch Length setting. You can set the Stitch Length from "1" to "10", with a lower number having a shorter stitch and a higher number having a longer stitch. The stitch length setting does not indicate "Stitches per inch", but will be consistent based on your sewing machine. The Stitch Length setting will be set to "5" every time you turn on the SureStitch.