

steam ironer 560/580

german engineering

Ersatzteile-Liste
List of spare parts
Liste des pièces détachées
Catalogo pezzi staccati
Lista de piezas de repuesto

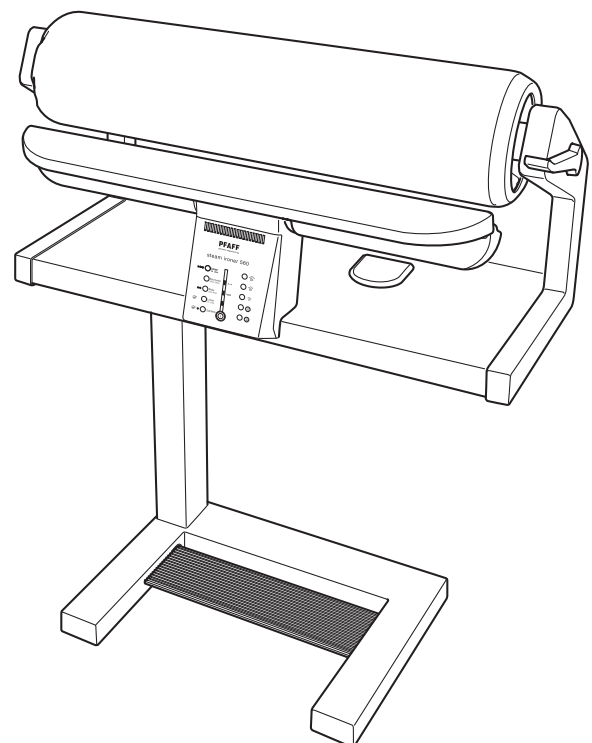

Nicht nummerierte Teile im Katalog werden nicht geliefert.

The parts mentioned without number in the parts list are not available.

Les pièces qui ne sont pas numérotées dans la liste de pièces détachées ne peuvent être livrées.

Pezzi non catalogati non sono disponibili.

Las piezas de repuesto sin número en esta lista no se entregarán.

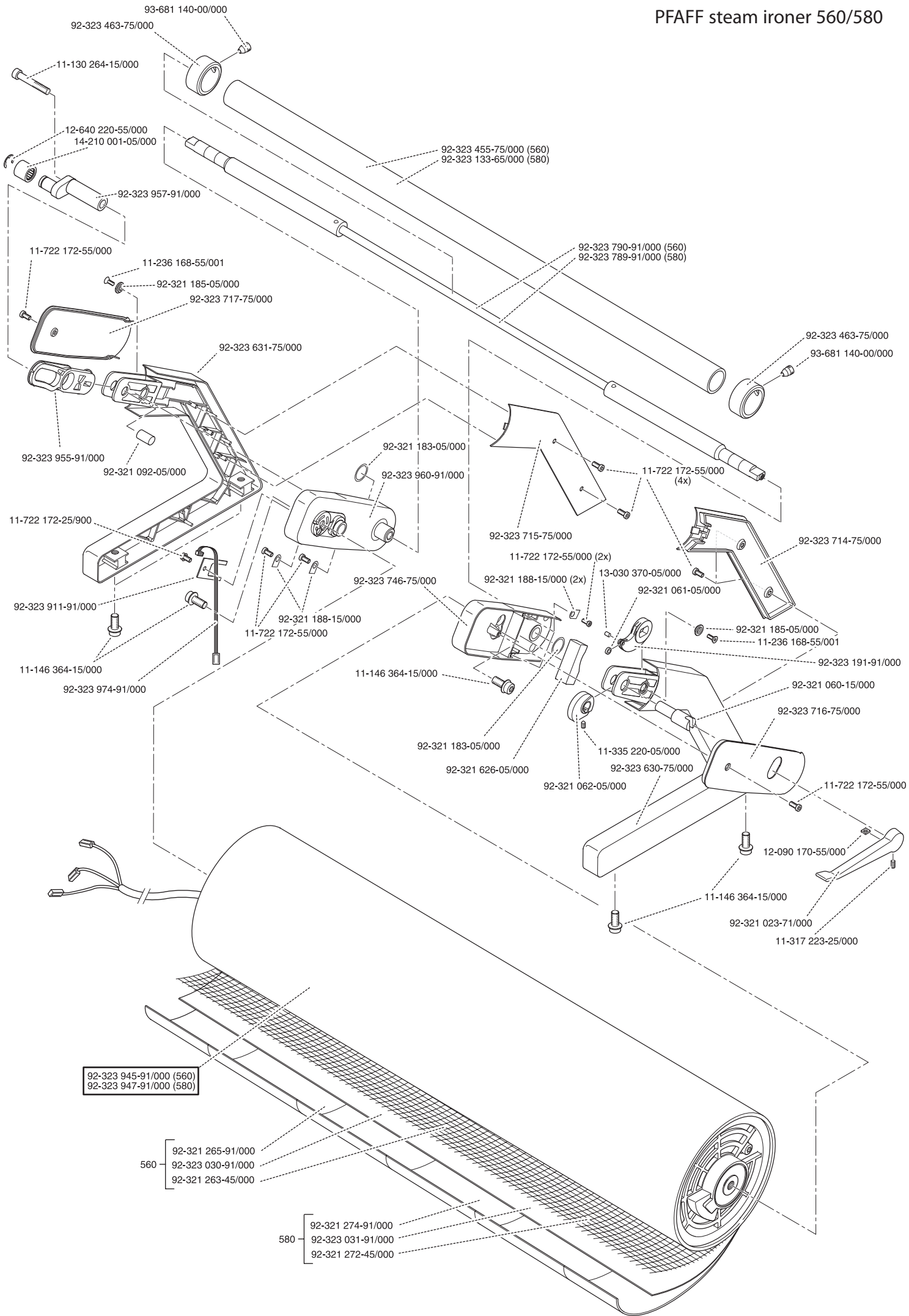

PFAFF steam ironer 560 / 580

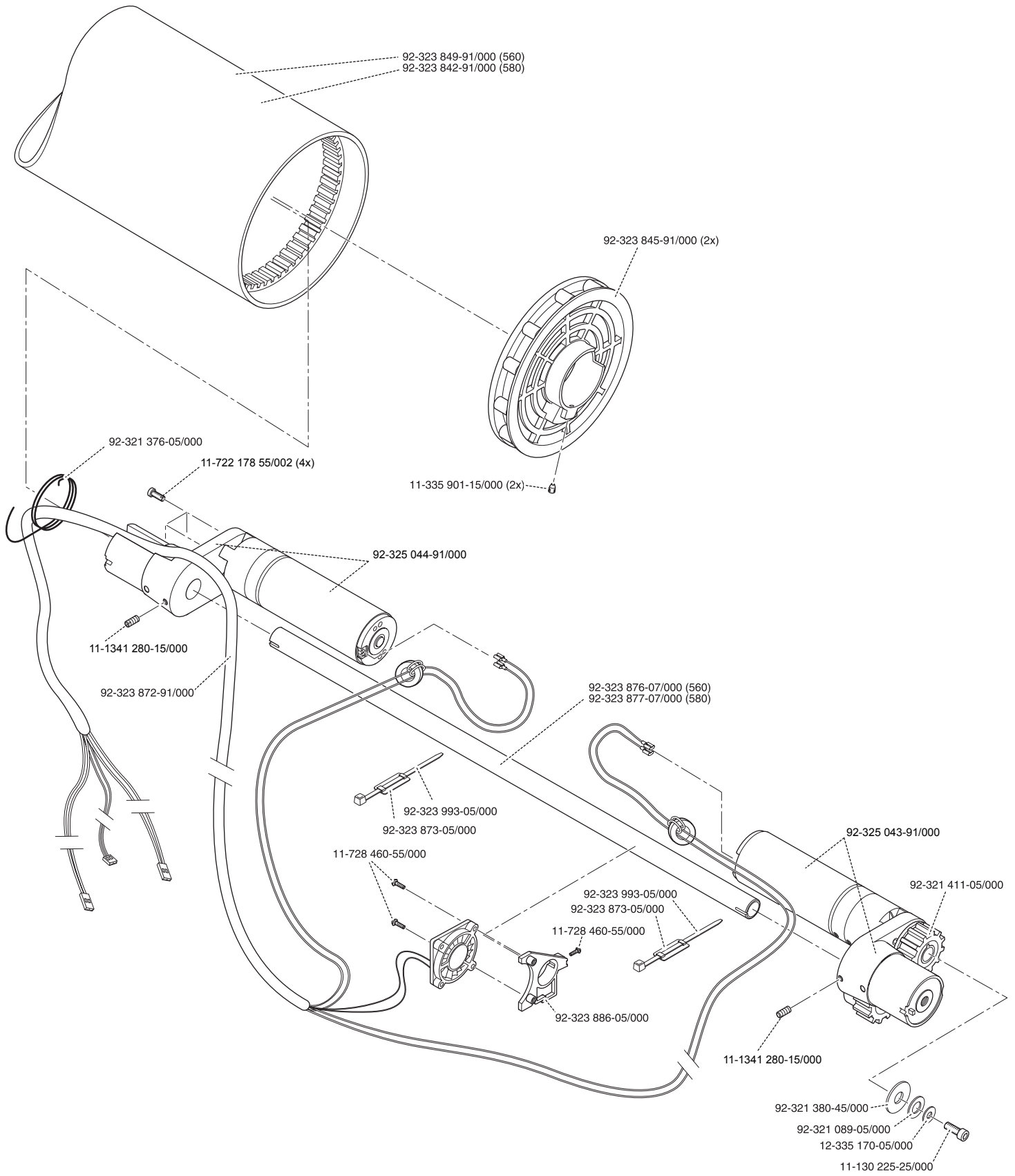

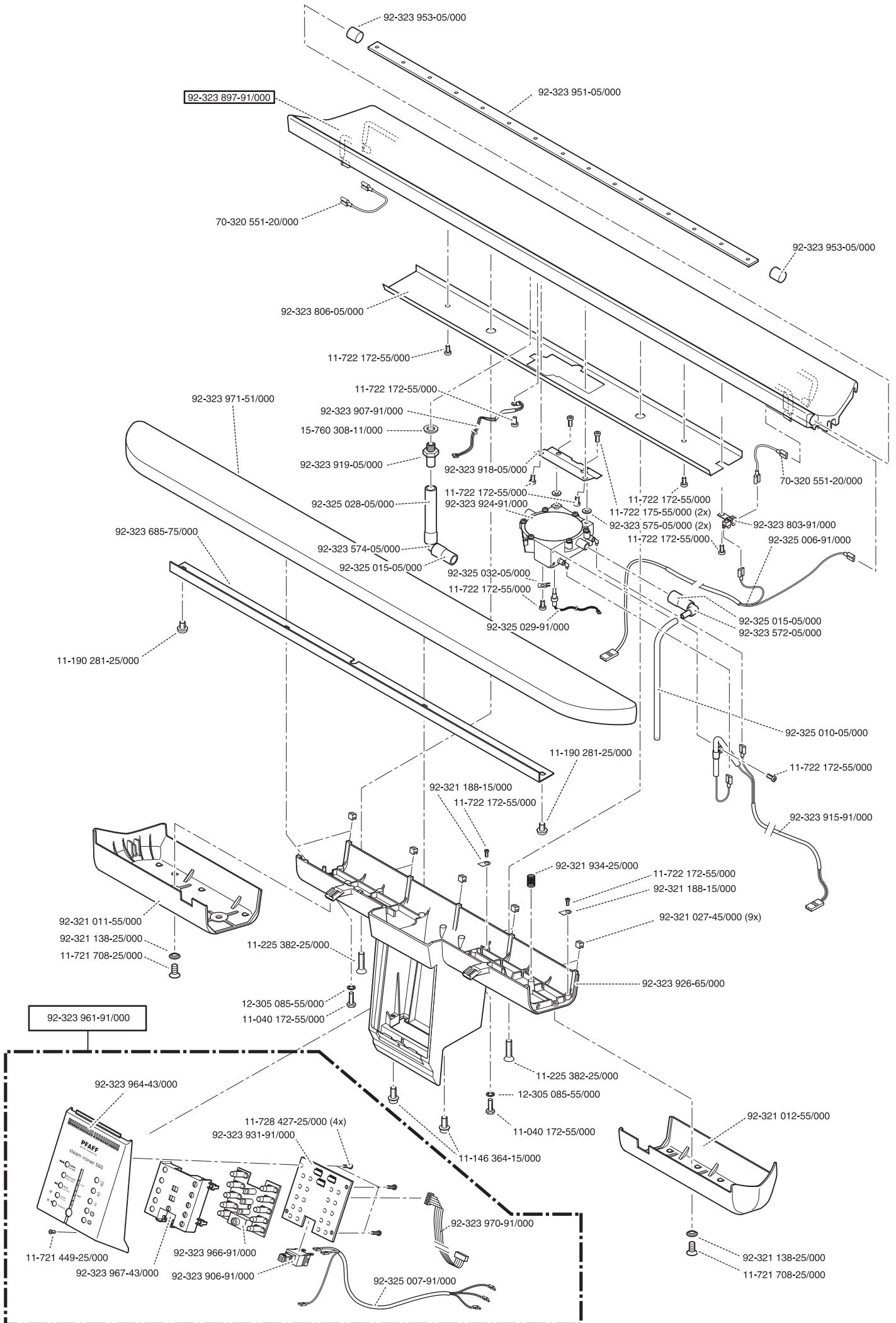

PFAFF steam ironer 580

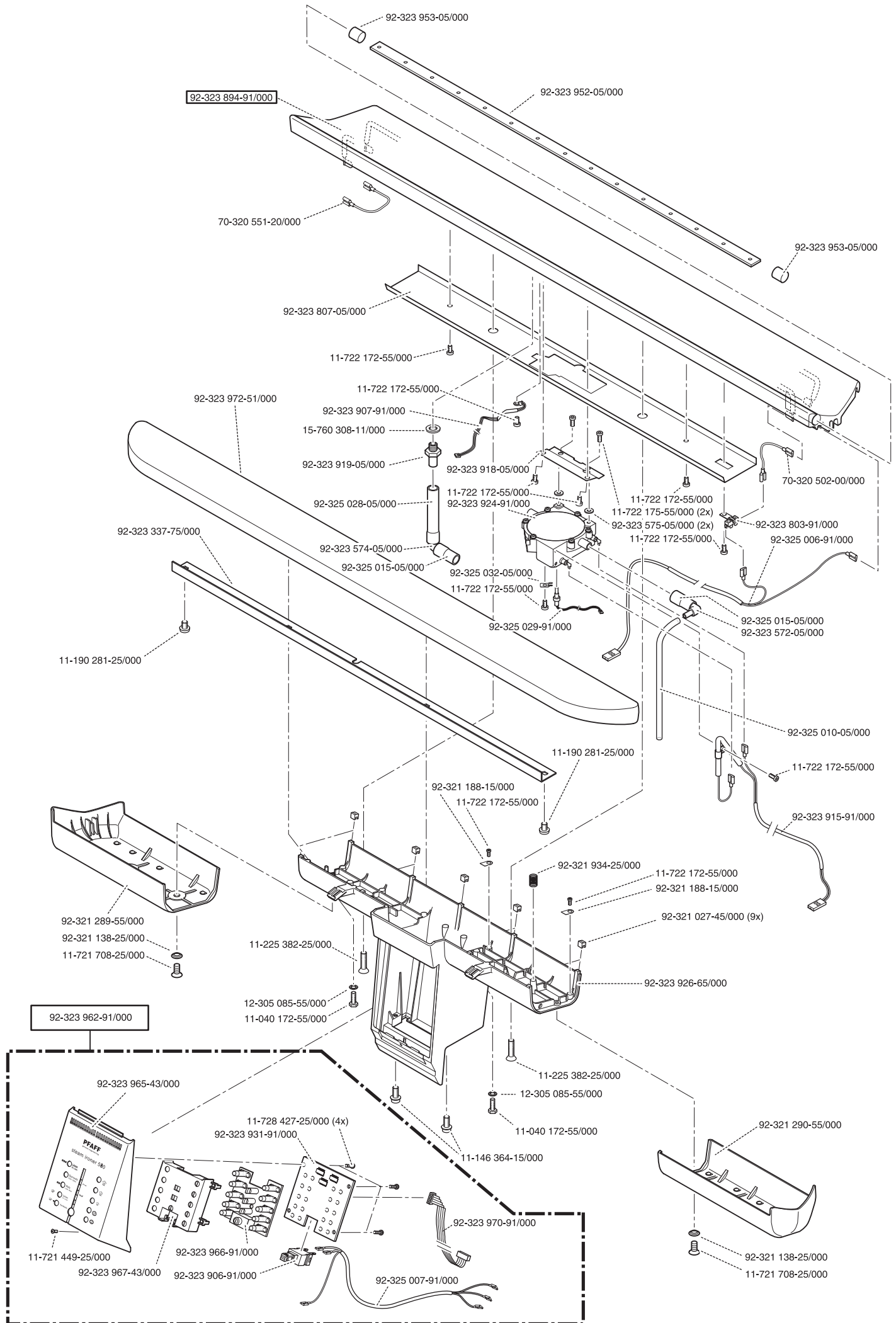

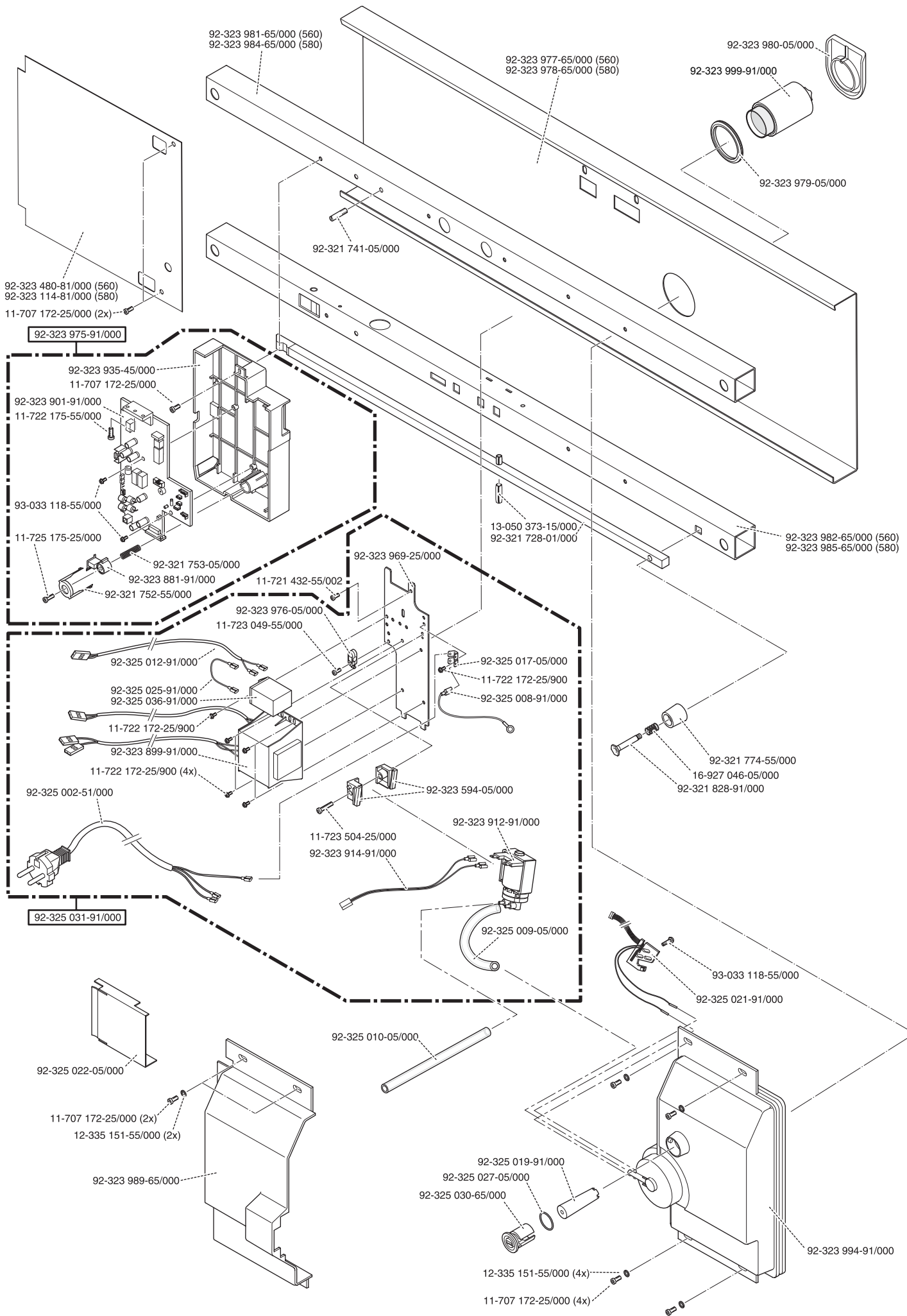

PFAFF steam ironer 560 / 580

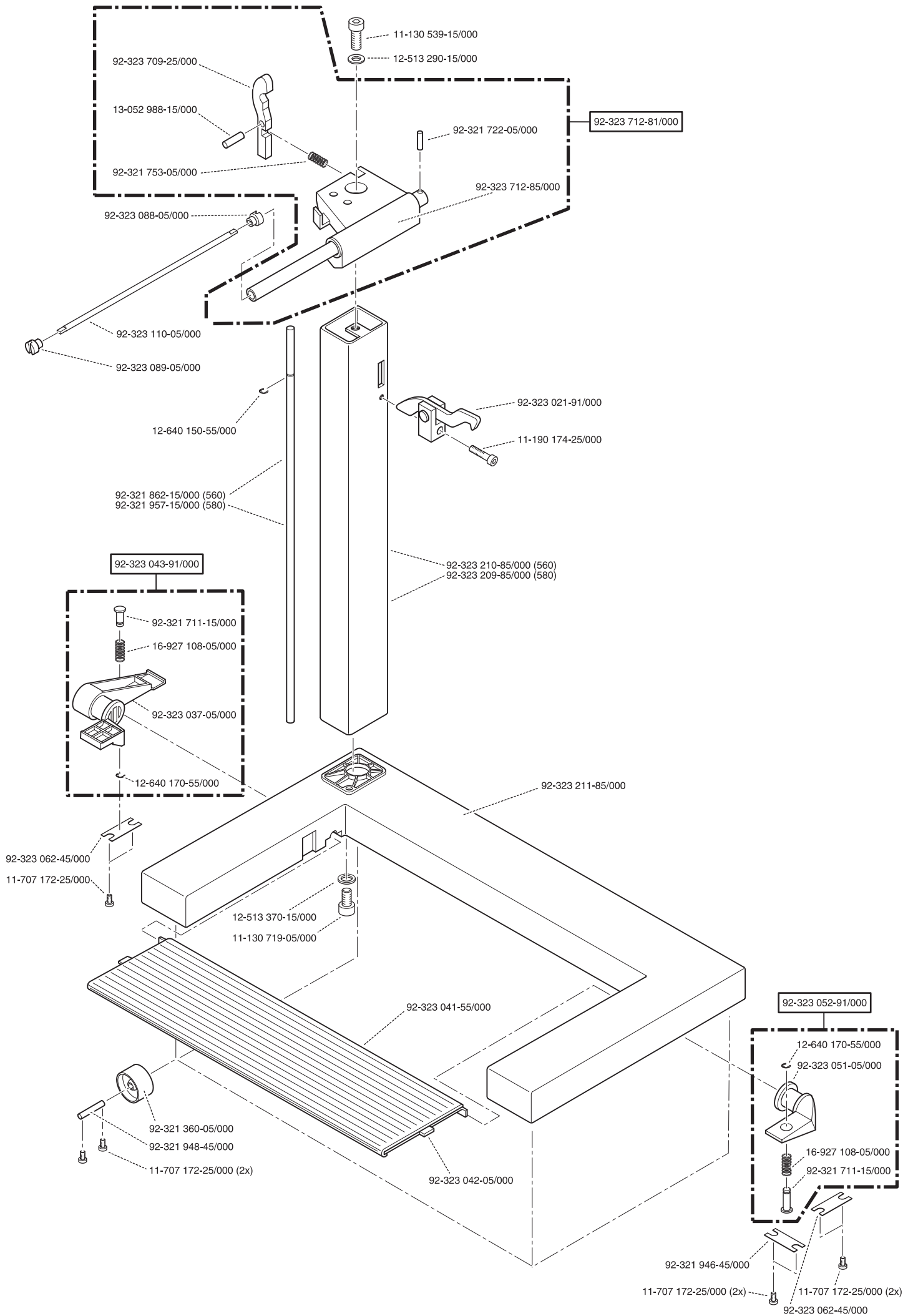

Nummernverzeichnis • Numerical Index • Index • Elenco dei Numeri • Indice numérico

11-040 172-55/000	Sechsk.-Schraube M6x25	hexagon screw M6x25	3, 4
11-130 225-25/000	SHR EN ISO 4762-M5x10-10.9	screw EN ISO 4762-M5x10-10.9	2
11-130 264-15/000	SHR ISO 7380-M5x60-10.9	screw ISO 7380-M5x60-10.9	1
11-130 539-15/000	SHR ISO 4762 (DIN 912)	screw ISO 4762 (DIN 912)	6
11-130 719-05/000	SHR ISO 4762 (DIN 912)	screw ISO 4762 (DIN 912)	6
11-146 364-15/000	SHR PN11146-M 8X20	screw PN11146-M 8X20	1, 3, 4
11-190 174-25/000	SHR DIN 7985-M 4x8	screw DIN 7985-M 4x8	6
11-190 281-25/000	SHR ISO 7045-M6	screw ISO 7045-M6	3, 4
11-225 382-25/000	SHR M8x40 D7991	screw M8x40 D7991	3,4
11-236 168-55/001	SHR DIN 965-M 4x8	screw DIN 965-M 4x8	1
11-317 223-25/000	Gewindestift ISO 4766-M 5x10	set screw ISO 4766-M 5x10	1
11-335 220-05/000	Gewindestift DIN 914-M 5x8	set screw DIN 914-M 5x8	1
11-335 901-15/000	Gewindestift DIN 914-M 6x8	set screw DIN 914-M 6x8	2
11-341 280-15/000	Gewindestift DIN 916-M 6x8	set screw DIN 916-M 6x8	2
11-707 172-25/000	SHR AM 4x8 DIN 7516	AM 4x8 DIN 7516	5, 6
11-721 432-55/002	SHR D7500-BE M4x6	screw D7500-BE M4x6	5
11-721 449-25/000	SHR D7500 M 4x8	screw D7500 M 4x8	3, 4
11-721 708-25/000	SHR D7500 M 6x12	screw D7500 M 6x12	3, 4
11-722 172-25/900	SHR PN11722-M 4x8 mit Scheibe	screw PN11722-M 4x8 with disk	1, 5
11-722 172-55/000	SHR PN11722-M 4x8	screw PN11722-M 4x8	1, 3, 4, 5
11-722 175-55/000	SHR PN 11722-M 4x10	screw PN 11722-M 4x10	3, 4, 5
11-722 178-55/002	SHR PN 11722-M 4x12	screw PN 11722-M 4x12	2
11-723 049-55/000	SHR PN11723-M 4x18-T20	screw PN11723-M 4x18-T20	5
11-723 504-25/000	SHR PN11723-M 4x25-T20	screw PN11723-M 4x25-T20	5
11-725 175-25/000	SHR F3,5x13 N11725	screw F3,5x13 N11725	5
11-728 427-25/000	SHR PN11728-F 3x10	screw PN11728-F 3x10	3, 4
11-728 460-55/000	SHR PN11728-F-3x16	screw PN11728-F-3x16	2
12-090 170-55/000	Mutter DIN 562-M 5	nut DIN 562-M 5	1
12-305 085-55/000	SHB ISO 7089-6-200HV-verzinkt	washer ISO 7089-6-200HV-galvanized	3,4
12-335 151-55/000	SHB DIN 9021-4,3	washer DIN 9021-4,3	5
12-335 170-05/000	SHB DIN 9021-5,3-140HV-A2	washer DIN 9021-5,3-140HV-A2	2
12-513 290-15/000	SISHB PH12513-12	retaining washer PH12513-12	6
12-513 370-15/000	SISHB PH12513-16	retaining washer PH12513-16	6
12-640 150-55/000	SISHB DIN 6799-4	retaining washer DIN 6799-4	6
12-640 170-55/000	SISHB DIN 6799-5	retaining washer DIN 6799-5	6
12-640 220-55/000	SISHB 9 DIN 6799	retaining washer 9 DIN 6799	1
13-030 370-05/000	Zylinderstift 6M6x10 DIN 7	helical pin 6M6x10 DIN 7	1
13-050 373-15/000	Spannstift ISO 8752-6x12	tightening pin ISO 8752-6x12	5
13-052 988-15/000	Spannstift ISO 8750-6x22	tightening pin ISO 8750-6x22	6
13-071 100-75/000	Passkerbstift ISO 8746 6x18	edged adjusting pin ISO 8746 6x18	2
14-210 001-05/000	Nadellager	pin bearing	1
15-760 308-11/000	Dichtscheibe D7603-A8x11,5	leakproof plate D7603-A8x11,5	3, 4
16-927 046-05/000	Fed. 0,63x8x16 D2098	spring 0,63x8x16 D2098	5
16-927 108-05/000	Fed. 1,25x8x33 D2098	spring 1,25x8x33 D2098	6
70-320 502-00/000	Leitung PH 73010-1x90	cable PH 73010-1x90	4
70-320 551-20/000	Leitung PH 73010-H05S-K, WS-1X70-	cable PH 73010-H05S-K, WS-1X70-	3, 4
92-321 011-55/000	Pressstoffkappe links	pressed material cap left	3
92-321 012-55/000	Pressstoffkappe rechts	pressed material cap right	3
92-321 023-71/000	Auslösehebel	release lever	1
92-321 027-45/000	Kappe	cap	3, 4
92-321 060-15/000	Auslösebolzen	release bolt	1
92-321 061-05/000	Rolle	roller	1
92-321 062-05/000	Spannexzenter	tensioning eccentric	1
92-321 089-05/000	Scheibe	washer	2
92-321 092-05/000	Exzenterbolzen	eccentric bolt	1
92-321 138-25/000	Formscheibe	grinding plate	3, 4

Nummernverzeichnis • Numerical Index • Index • Elenco dei Numeri • Índice numérico

92-321 183-05/000	Scheibe	washer	1
92-321 185-05/000	Scheibe	washer	1
92-321 188-15/000	Kabelschelle	cable clamp	1, 3, 4
92-321 263-45/000	Jutebezug	jute cladding	1
92-321 265-91/000	Walzenbezug kpl. 560	roll cladding cpl.	1
92-321 272-45/000	Jutebezug	jute cladding	1
92-321 274-91/000	Walzenbezug kpl. 580	roll cladding cpl.	1
92-321 289-55/000	Pressstoffkappe links	pressed material cap left	4
92-321 290-55/000	Pressstoffkappe rechts	pressed material cap right	4
92-321 360-05/000	Rad	wheel	6
92-321 376-05/000	Feder	spring	2
92-321 380-45/000	Scheibe	washer	2
92-321 411-05/000	Zahnrad	gear wheel	2
92-321 626-05/000	Bremsklotz	brake block	1
92-321 711-15/000	Bolzen	bolt	6
92-321 722-05/000	Zylinderstift	helical pin	6
92-321 728-01/000	Auslösestange kpl.	release bar cpl.	5
92-321 741-05/000	Gewindestift	set screw	5
92-321 752-55/000	Deckel	cover	5
92-321 753-05/000	Druckfeder	compression spring	5, 6
92-321 774-55/000	Rundpuffer	round-buffer	5
92-321 828-91/000	Druckstift	presser pin	5
92-321 862-15/000	Schaltstange	switching rod	6
92-321 934-25/000	Druckfeder	compression spring	3, 4
92-321 946-45/000	Lasche	fixing plate	6
92-321 948-45/000	Achse	shaft	6
92-321 957-15/000	Schaltstange	switching rod	6
92-323 021-91/000	Feststeller kpl.	arresting device cpl.	6
92-323 030-91/000	Paddingbezug	padding	1
92-323 031-91/000	Paddingbezug	padding	1
92-323 037-05/000	Schalthebel links	control lever left	6
92-323 041-55/000	Abdeckprofil	covering profile	6
92-323 042-05/000	Schaltleiste	connecting block	6
92-323 043-91/000	Schalthebel links kpl.	control lever left cpl.	6
92-323 051-05/000	Schalthebel rechts	control lever right	6
92-323 052-91/000	Schalthebel rechts kpl.	control lever right cpl.	6
92-323 062-45/000	Lasche	fixing plate	6
92-323 088-05/000	Kupplung links	clutch left	6
92-323 089-05/000	Kupplung rechts	clutch right	6
92-323 110-05/000	Drehstab	torsion bar	6
92-323 114-81/000	Abdeckblech kpl.	cover plate cpl.	5
92-323 133-65/000	Verbindungsrohr lackiert	connecting tube lacquered	1
92-323 191-91/000	Hebel kpl.	lever cpl.	1
92-323 209-85/000	Säule lackiert	column lacquered	6
92-323 210-85/000	Säule lackiert	column lacquered	6
92-323 211-85/000	Konsole lackiert	console lacquered	6
92-323 337-75/000	Schiene lackiert	bar lacquered	4
92-323 455-75/000	Verbindungsrohr lackiert	connecting tube lacquered	1
92-323 463-75/000	Hülsenklemme lackiert	sleeve lacquered	1
92-323 480-81/000	Abdeckblech kpl.	cover plate cpl.	5
92-323 572-05/000	Rohrwinkel	pipe angle	3, 4
92-323 574-05/000	Rohrwinkel	pipe angle	3, 4
92-323 575-05/000	Scheibe	washer	3, 4
92-323 594-05/000	Pumpenhalter	pump-holder	5
92-323 630-75/000	Stützarm rechts lackiert	supporting arm right lacquered	1
92-323 631-75/000	Stützarm links lackiert	supporting arm left lacquered	1

Nummernverzeichnis • Numerical Index • Index • Elenco dei Numeri • Indice numérico

92-323 685-75/000	Schiene lackiert	bar lacquered	3
92-323 709-25/000	Rasthebel	drop-in lever	6
92-323 712-81/000	Lagerkopf kpl.	bearing head cpl.	6
92-323 712-85/000	Lagerkopf lackiert	bearing head lacquered	6
92-323 714-75/000	Stützarmdeckel rechts	supporting arm lid right	1
92-323 715-75/000	Stützarmdeckel links	supporting arm lid left	1
92-323 716-75/000	Lagerarmdeckel rechts	bearingarm cover right	1
92-323 717-75/000	Lagerarmdeckel links	bearingarm cover left	1
92-323 746-75/000	Lagerarm rechts lackiert	bearingarm right lacquered	1
92-323 789-91/000	Drehstabfeder kpl.	torsion bar spring cpl.	1
92-323 790-91/000	Drehstabfeder kpl.	torsion bar spring cpl.	1
92-323 803-91/000	Temperatursicherung	temperature fuse	3, 4
92-323 806-05/000	Abstrahlblech	reflect plate	3
92-323 807-05/000	Abstrahlblech	reflect plate	4
92-323 842-91/000	Walze mit Zahnkranz kpl.	roll with gear rim cpl.	2
92-323 845-91/000	Lagerhalter kpl. AU	bearing bracket cpl. AU	2
92-323 849-91/000	Walze mit Zahnkranz kpl.	roll with gear rim cpl.	2
92-323 872-91/000	Kabelbaum	cable	2
92-323 873-05/000	Isolierplatte	insulating board	2
92-323 876-07/000	Flanschrohr bearbeitet	flange pipe worked	2
92-323 877-07/000	Flanschrohr bearbeitet	flange pipe worked	2
92-323 881-91/000	Druckstück kpl.	pressure block cpl.	5
92-323 886-05/000	Lüfter- und Kabelhalter	fan- and cable support	2
92-323 894-91/000	Heizschuh kpl.	heating shoe cpl.	4
92-323 897-91/000	Heizschuh kpl.	heating shoe cpl.	3
92-323 899-91/000	Trafo kpl.	transformer cpl.	5
92-323 901-91/000	Leiterplatte bestückt	main pcb assembled	5
92-323 906-91/000	Druckschalter 1 pol.	appliance switch 1 pol.	3, 4
92-323 907-91/000	Temp.-Sensor kpl.	temp.-sensor cpl.	3, 4
92-323 911-91/000	Leiterplatte bestückt senken/heben	pcb assembled up/down	1
92-323 912-91/000	Wasserpumpe	water pump	5
92-323 914-91/000	Pumpenkabel	pump cable	5
92-323 915-91/000	Kabelbaum kpl.	cable cpl.	3, 4
92-323 918-05/000	Schiene	bar	3, 4
92-323 919-05/000	Rohrstutzen	nipple	3, 4
92-323 924-91/000	Verdampfer kpl.	vaporizer cpl.	3, 4
92-323 926-65/000	Heizschuhständer lackiert	heating-shoe holder paint	3, 4
92-323 931-91/000	Leiterplatte bestückt	panel board assembled	3, 4
92-323 935-45/000	Anschlussgehäuse	connecting box	5
92-323 945-91/000	Walze kpl. mit Jutebezug	roll cpl. with jute cladding	1
92-323 947-91/000	Walze kpl. mit Jutebezug	roll cpl. with jute cladding	1
92-323 951-05/000	Lochblech	perforated sheet	3
92-323 952-05/000	Lochblech	perforated sheet	4
92-323 953-05/000	Verschlussstopfen	locking plug	3, 4
92-323 955-91/000	Lagerhebel kpl.	bearing lever cpl.	1
92-323 957-91/000	Kurbel kpl.	crank cpl.	1
92-323 960-91/000	Lagerarm montiert links	bearingarm mounted left	1
92-323 961-91/000	Bedienpult kpl. 560	board cpl. 560	3
92-323 962-91/000	Bedienpult kpl. 580	board cpl. 580	4
92-323 964-43/000	Bedienpult bedruckt 560	board printed 560	3
92-323 965-43/000	Bedienpult bedruckt 580	board printed 580	4
92-323 966-91/000	Schaltmatte	keypad	3, 4
92-323 967-43/000	Niederhalter	holder frame	3, 4
92-323 969-25/000	Träger für Trafobefestigung	bracket f. transformer fixing	5
92-323 970-91/000	Displayleitung	display cable	3, 4
92-323 971-51/000	Auflageplatte	bearing plate	3

Nummernverzeichnis • Numerical Index • Index • Elenco dei Numeri • Índice numérico

92-323 972-51/000	Auflageplatte	bearing plate	4
92-323 974-91/000	Stegleitung (senken/heben)	ribbon cable (up/down)	1
92-323 975-91/000	Anschlussgehäuse kpl.	connecting box cpl.	5
92-323 976-05/000	Zugentlastungsschelle	stress relief clip	5
92-323 977-65/000	Tischplatte lackiert	table plate lacquered	5
92-323 978-65/000	Tischplatte lackiert	table plate lacquered	5
92-323 979-05/000	Dichtung	gasket	5
92-323 980-05/000	Verschluss	closure	5
92-323 981-65/000	Strebe vorne lackiert	brace front lacquered	5
92-323 982-65/000	Strebe hinten lackiert	brace behind lacquered	5
92-323 984-65/000	Strebe vorne lackiert	brace front lacquered	5
92-323 985-65/000	Strebe hinten lackiert	brace behind lacquered	5
92-323 989-65/000	Abdeckung	cover	5
92-323 993-05/000	Kabelbinder	cable clip	2
92-323 994-91/000	Wasserbehälter montiert	tank mounted	5
92-323 999-91/000	Patrone in Beutel kpl	Cartridge in Bootle kpl	5
92-325 002-51/000	Netzzuleitung	supply main	5
92-325 006-91/000	Kabelbaum	cable	3, 4
92-325 007-91/000	Kabelbaum	cable	3, 4
92-325 008-91/000	Schutzleiter	ground wire	5
92-325 009-05/000	Schlauch 4x2x115	tube 4x2x115	5
92-325 010-05/000	Schlauch 4x2x290	tube 4x2x290	3, 4, 5
92-325 012-91/000	Kabelbaum	cable	5
92-325 015-05/000	Schlauch 6x2x25	tube 6x2x25	3, 4
92-325 017-05/000	Steckverteiler	flat tab	5
92-325 019-91/000	Schwimmer kpl.	float cpl.	5
92-325 021-91/000	Leiterplatte bestückt	pcb assembled	5
92-325 022-05/000	Kabelschutz	cable protection	5
92-325 025-91/000	Kabel	cable	5
92-325 027-05/000	O-Ring 26x2	O-ring seal 26x2	5
92-325 028-05/000	Schlauch (6x2)x68	tube (6x2)x68	3, 4
92-325 029-91/000	Temp.-Sensor kpl.	temp.-sensor cpl.	3, 4
92-325 030-65/000	Verschluss für Wasserbehälter	closure for tank	5
92-325 031-91/000	Träger mont. 560/580 VDE	bracket assambled 560/580 VDE	5
92-325 032-05/000	Haltefeder	retaining spring	3, 4
92-325 036-91/000	Relais bedruckt	relay prints on	5
92-325 043-91/000	Motor - Drehen Kpl	Motor- Turning Kpl.	2
92-325 044-91/000	Motor - Heben/Senken Kpl	Motor- Lifting /Lowering kpl	2
93-033 118-55/000	Schraube 3x8	screw 3x8	5
93-681 140-00/000	Gewindestift mit Spitze	set screw with conical tip	1

Notizen • Notes • Notas • Note

PFAFF

© 2006
Copyright VSM Group AB
All rights reserved

Technische Änderungen vorbehalten

Subject to alterations in design

Sous toute réserve de modifications
techniques

Salvo modificaciones técnicas

Con riserva di modifiche tecniche

104 22 79-96