

Threading Chart

Threading, Chainstitch

1. Threading chainstitch looper (purple): see page 37
2. Chain-needle, brown markings (use yellow tension): see page 38

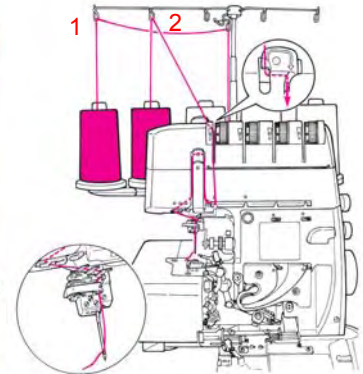
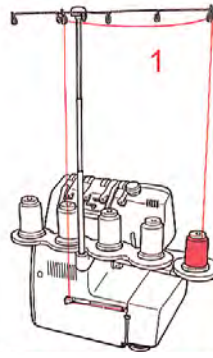
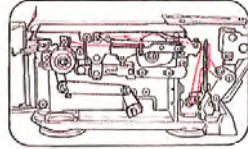

3-thread overlock (left needle)+Chain stitch

1. Upper looper thread, blue markings: see page 33
2. Lower looper thread, red markings: see page 34
3. Left-hand needle, use green markings and tension: see page 35
4. Threading chainstitch looper (purple): see page 37
5. Chain-needle, brown markings (use yellow tension): see page 38

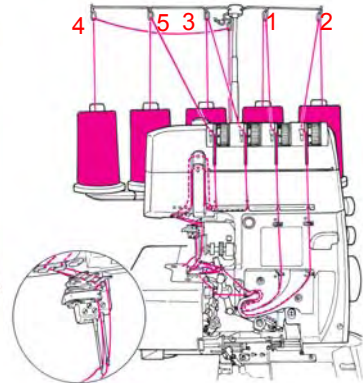
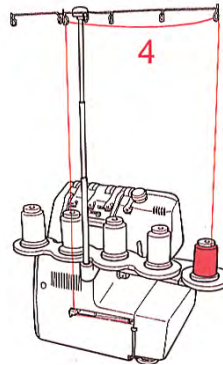
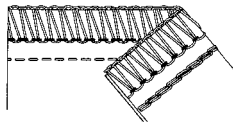

3-thread overlock (right needle)+Chain stitch

1. Upper looper thread, blue markings: see page 33
2. Lower looper thread, red markings: see page 34
3. Right-hand needle, green markings: see page 35
4. Threading chainstitch looper (purple): see page 37
5. Chain-needle, brown markings (use yellow tension): see page 38

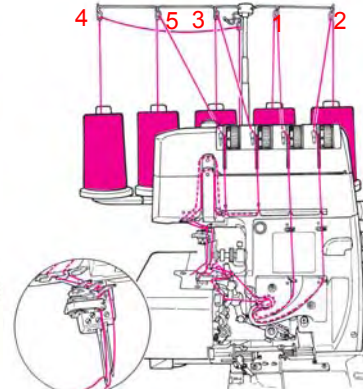
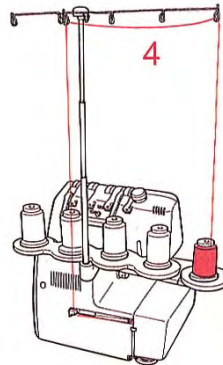
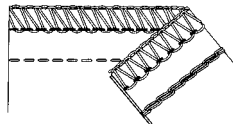

2-thread overlock (left needle)+Chain stitch

1. Use the upper looper converter: see page 21
2. Lower looper thread, red markings: see page 34
3. Left-hand needle, use green markings and tension: see page 35
4. Threading chainstitch looper (purple): see page 37
5. Chain-needle, brown markings (use yellow tension): see page 38

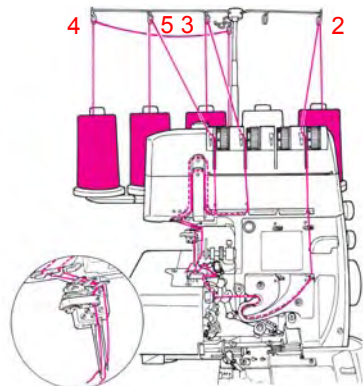
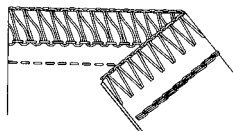

2-thread overlock (right needle)+Chain stitch

1. Use the upper looper converter: see page 21
2. Lower looper thread, red markings: see page 34
3. Right-hand needle, green markings: see page 35
4. Threading chainstitch looper (purple): see page 37
5. Chain-needle, brown markings (use yellow tension): see page 38

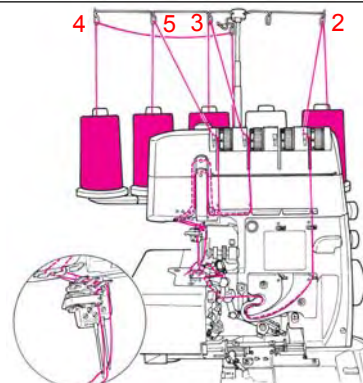
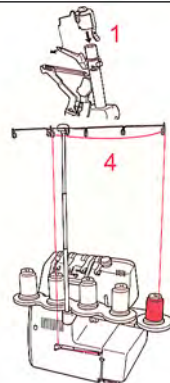
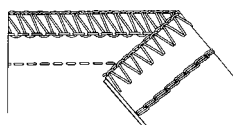

4 thread cover stitch

1. Threading chainstitch looper (purple): see page 46
2. Cover stitch R needle, pink markings: see page 47
3. Cover stitch C needle pink markings: see page 48
4. Cover stitch L needle pink markings: see page 49

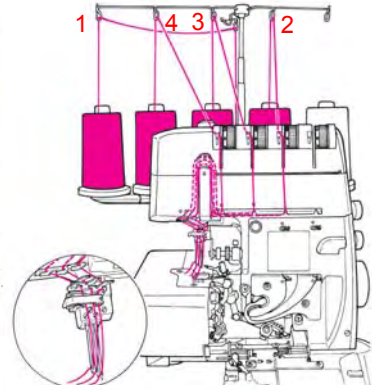
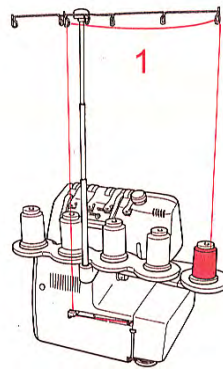
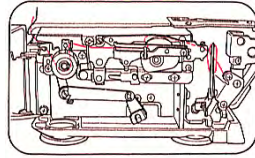
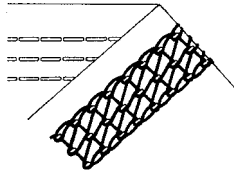

Threading 3 thread cover stitch (wide L,R)

1. Threading chainstitch looper (purple): see page 46
2. Cover stitch R needle, pink markings: see page 47
3. Cover stitch L needle pink markings: see page 49

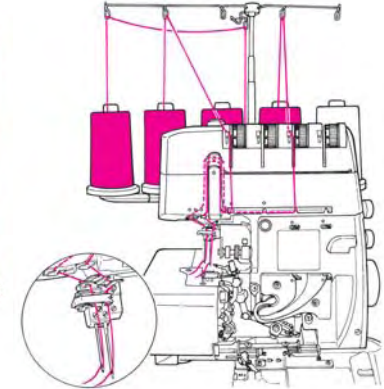
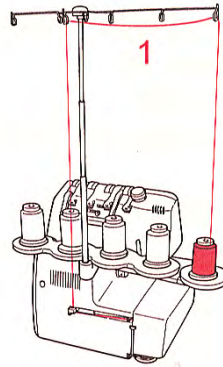
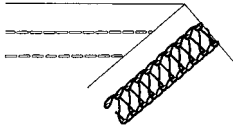

Threading 3 thread cover stitch (narrow L,C)

1. Threading chainstitch looper (purple): see page 46
2. Cover stitch C needle pink markings: see page 48
3. Cover stitch L needle pink markings: see page 49

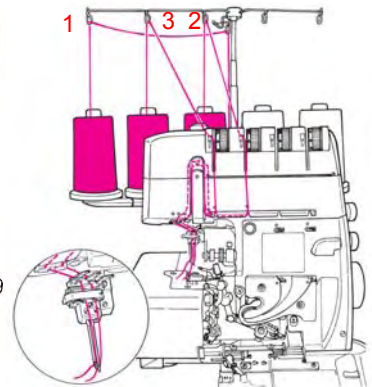
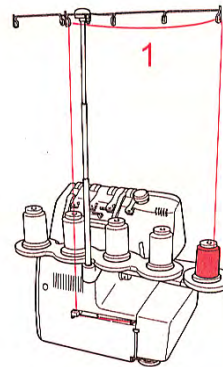
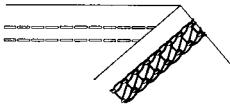

Threading 3 thread cover stitch (narrow C,R)

1. Threading chainstitch looper (purple): see page 46
2. Cover stitch R needle, pink markings: see page 47
3. Cover stitch C needle pink markings: see page 48



Diagrama de enhebrado

Enhebrado, punto de cadeneta

1. Enhebrado de la lanzadera punto cadeneta (lila): Seite 37
2. Enhebrar la aguja de punto de cadeneta (marcas marrón) (utilizar la tensión amarilla): Seite 38

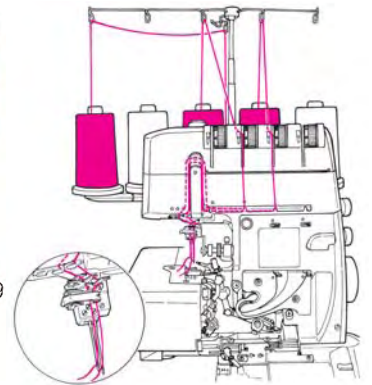
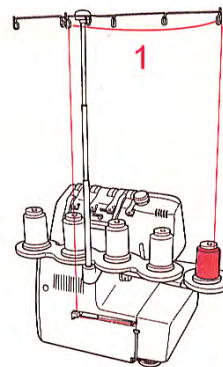
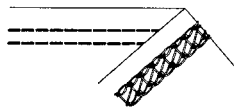
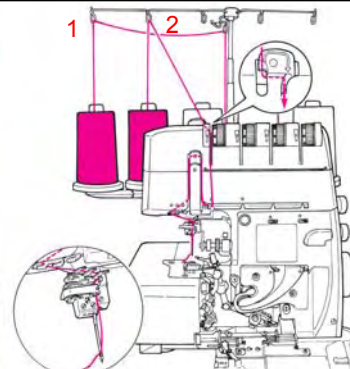
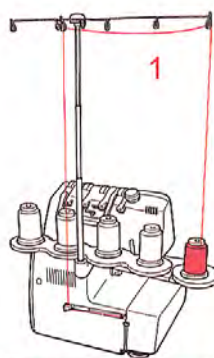
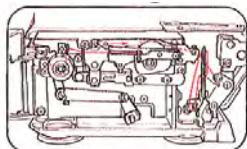

Enhebrado overlock de 3 hilos (aguja izquierda y punto de cadeneta)

1. Enhebrado de la lanzadera superior, marcas azules, véase pág. 33
2. Enhebrado de la lanzadera inferior, marcas rojas, véase pág. 34
3. Aguja izquierda, marcas verde (tensión verde), véase pág. 35
4. Enhebrado de la lanzadera cadeneta (lila) véase pág. 37
5. Aguja cadeneta, marcas marrón (utilizar la tensión amarilla), véase pág. 38

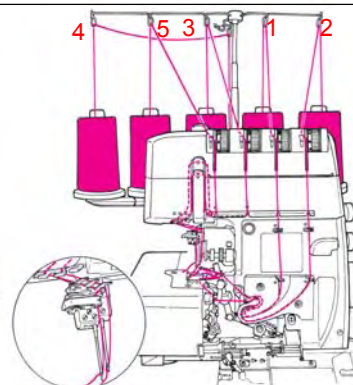
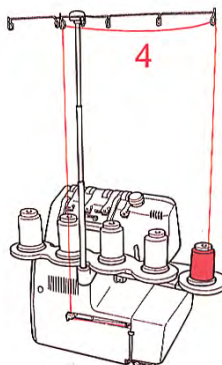
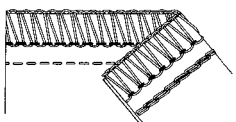

Enhebrado overlock de 3 hilos (aguja derecha y punto de cadeneta)

1. Enhebrado de la lanzadera superior, marcas azules, véase pág. 33
2. Enhebrado de la lanzadera inferior, marcas rojas, véase pág. 34
3. Aguja derecha, marcas verde, véase pág. 35
4. Enhebrado de la lanzadera cadeneta (lila) véase pág. 37
5. Aguja cadeneta, marcas marrón (utilizar la tensión amarilla), véase pág. 38

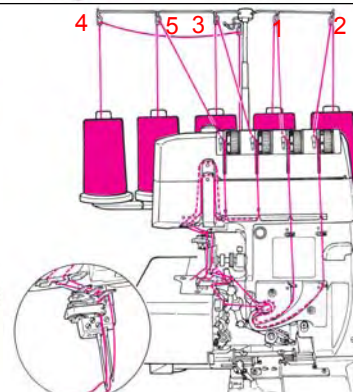
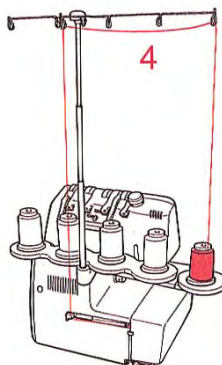
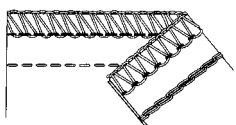

Enhebrado overlock de 2 hilos (aguja izquierda y punto de cadeneta)

1. Utilizar el transformador lanzadera ciega, véase pág. 21
2. Enhebrado de la lanzadera inferior, marcas rojas, véase pág. 34
3. Aguja izquierda, marcas verde (tensión verde), véase pág. 35
4. Enhebrado de la lanzadera cadeneta (lila) véase pág. 37
5. Aguja cadeneta, marcas marrón (utilizar la tensión amarilla), véase pág. 38

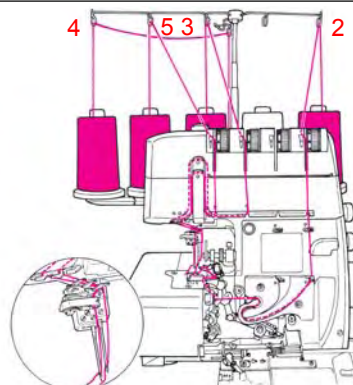
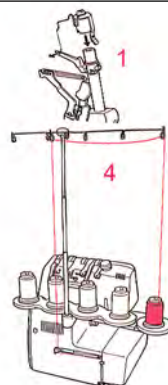
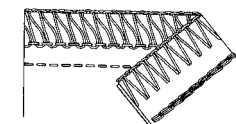

Enhebrado overlock de 2 hilos (aguja derecha y punto de cadeneta)

1. Utilizar el transformador lanzadera ciega, véase pág. 21
2. Enhebrado de la lanzadera inferior, marcas rojas, véase pág. 34
3. Aguja derecha, marcas verde, véase pág. 35
4. Enhebrado de la lanzadera cadeneta (lila) véase pág. 37
5. Aguja cadeneta, marcas marrón (utilizar la tensión amarilla), véase pág. 38

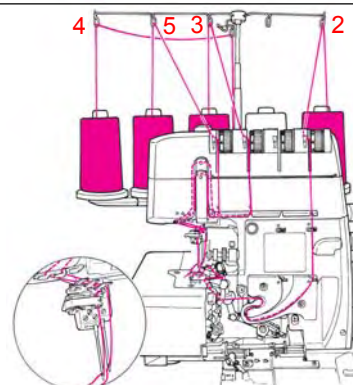
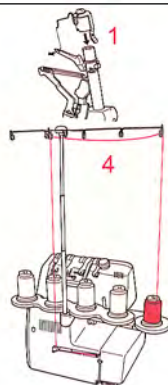
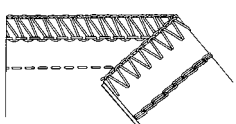

Enhebrado para punto de cobertura de 4 hilos

1. Enhebrado de la lanzadera cadeneta (lila) véase pág. 46
2. Punto de cobertura aguja R (rosa), véase pág 47
3. Punto de cobertura aguja C (rosa), véase pág 48
4. Punto de cobertura aguja L (rosa), véase pág 49

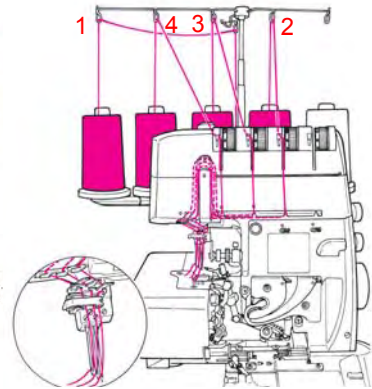
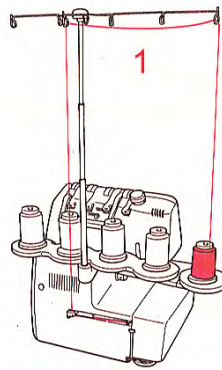
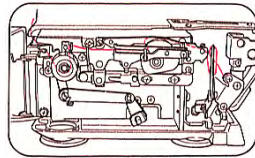
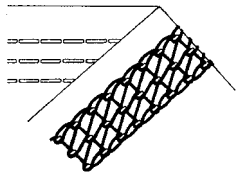

Enhebrado para punto de cobertura de 3 hilos (ancho L,R)

1. Enhebrado de la lanzadera cadeneta (lila) véase pág. 46
2. Punto de cobertura aguja R (rosa), véase pág 47
3. Punto de cobertura aguja L (rosa), véase pág 49

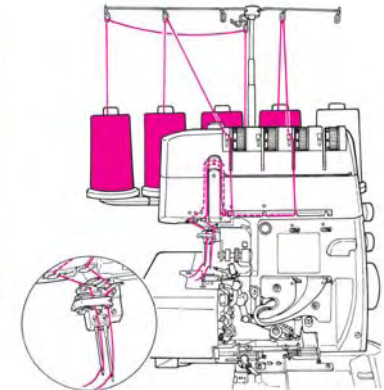
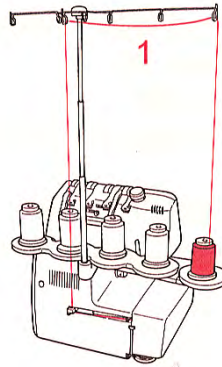
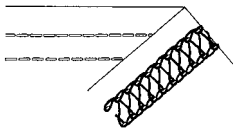

Enhebrado para punto de cobertura de 3 hilos (estrecho L,C)

1. Enhebrado de la lanzadera cadeneta (lila) véase pág. 46
2. Punto de cobertura aguja C (rosa), véase pág 48
3. Punto de cobertura aguja L (rosa), véase pág 49

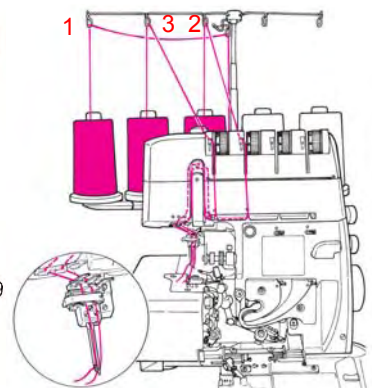
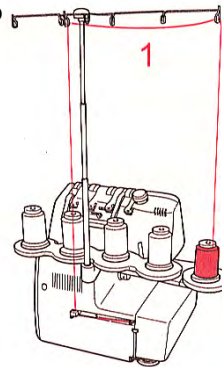
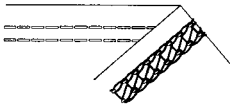

Enhebrado para punto de cobertura de 3 hilos (estrecho C,R)

1. Enhebrado de la lanzadera cadeneta (lila) véase pág. 46
2. Punto de cobertura aguja R (rosa), véase pág 47
3. Punto de cobertura aguja C (rosa), véase pág 48

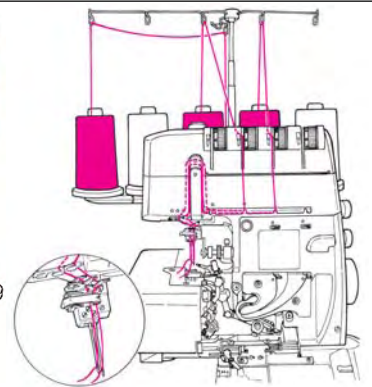
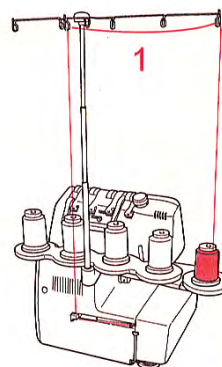

Einfädeldiagramm

Kettenstich einfädeln

1. Kettenstich Greifer einfädeln (violett), voir page 37
2. Kettenstich Nadel einfädeln (braun Markierung) (Gelbe Spannung verwenden), voir page 38

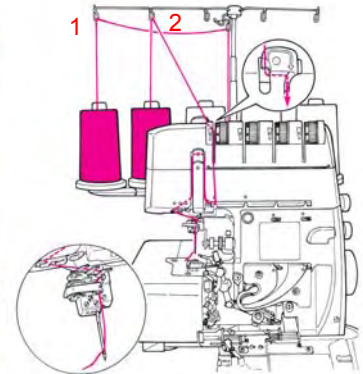
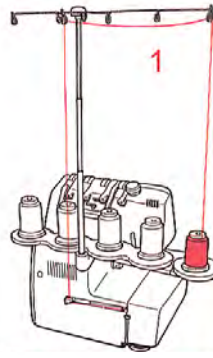
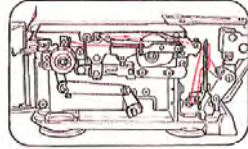

3 Faden Overlock (Linke Nadel) und Kettenstich

1. Obergreifer Faden, blaue Markierung: Seite 33
2. Untergreifer Faden, rote Markierung: Seite 34
3. Linke Nadel, grüne Markierung und Spannung verwenden: Seite 35
4. Kettenstich Greifer violette Markierung: Seite 37
5. Kettenstich Nadel braun Markierung (gelbe Spannung verwenden): Seite 38

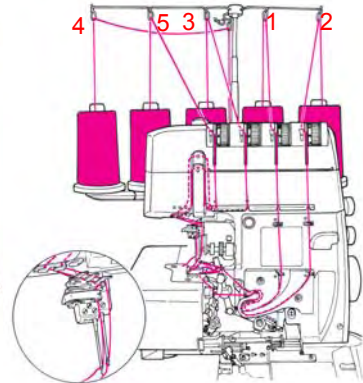
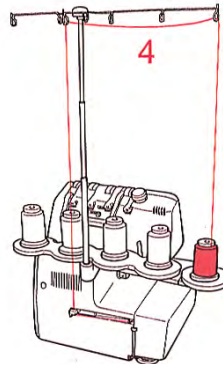
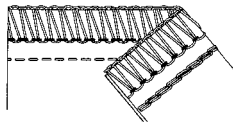

3 Faden Overlock (Rechte Nadel) und Kettenstich

1. Obergreifer Faden, blaue Markierung: Seite 33
2. Untergreifer Faden, rote Markierung: Seite 34
3. Rechte Nadel, grüne Markierung: Seite 35
4. Kettenstich Greifer violette Markierung: Seite 37
5. Kettenstich Nadel braun Markierung (gelbe Spannung verwenden): Seite 38

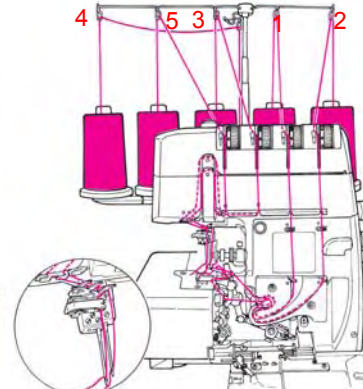
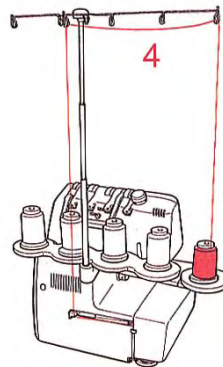
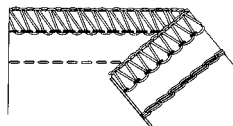

2 Faden Overlock (Linke Nadel) und Kettenstich

1. Obergreiferabdeckung montieren: Seite 21
2. Untergreifer Faden, rote Markierung: Seite 34
3. Linke Nadel, grüne Markierung und Spannung verwenden: Seite 35
4. Kettenstich Greifer violette Markierung: Seite 37
5. Kettenstich Nadel braun Markierung (gelbe Spannung verwenden): Seite 38

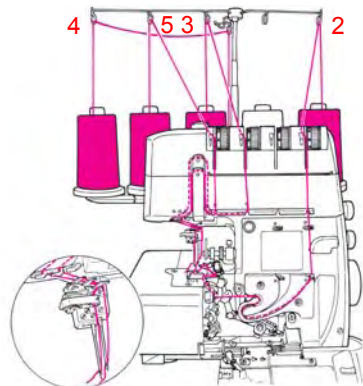
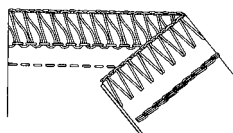

2 Faden Overlock (Rechte Nadel) und Kettenstich

1. Obergreiferabdeckung montieren: Seite 21
2. Untergreifer Faden, rote Markierung: Seite 34
3. Rechte Nadel, grüne Markierung: Seite 35
4. Kettenstich Greifer violette Markierung: Seite 37
5. Kettenstich Nadel braun Markierung (gelbe Spannung verwenden): Seite 38

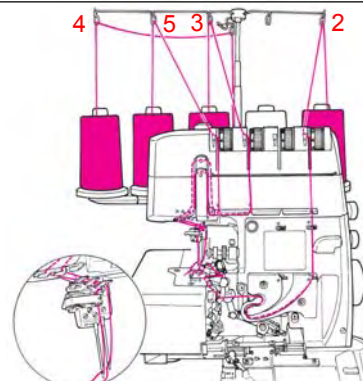
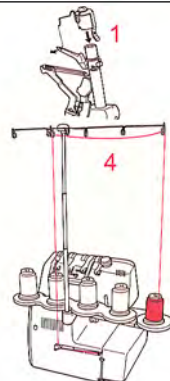
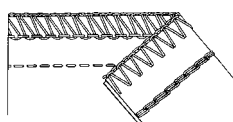

4 Faden Cover Stich

1. Kettenstich Greifer violette Markierung: Seite 46
2. Cover Stich R Nadel, rosa: Seite 47
3. Cover Stich C Nadel, rosa: Seite 48
4. Cover Stich C Nadel, rosa: Seite 49

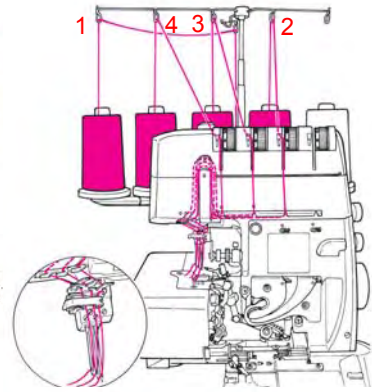
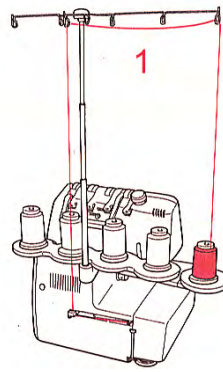
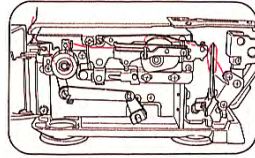
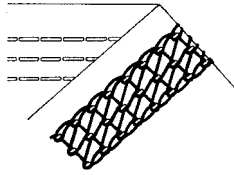

3 Faden Cover Stich Einfädeln (breit L,R)

1. Kettenstich Greifer violette Markierung: Seite 46
2. Cover Stich R Nadel, rosa: Seite 47
3. Cover Stich L Nadel, rosa: Seite 49

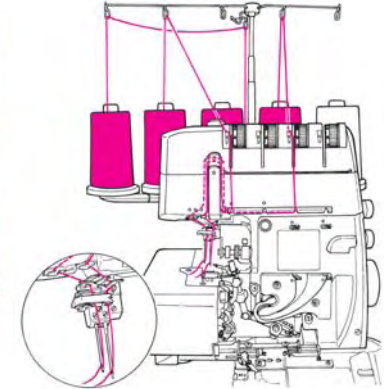
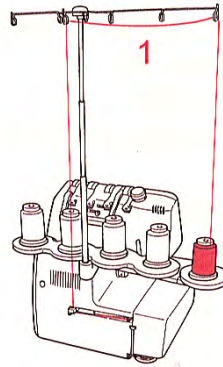
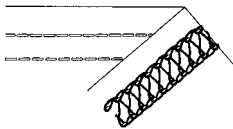

3 Faden Cover Stich Einfädeln (schmal L,C)

1. Kettenstich Greifer violette Markierung: Seite 46
2. Cover Stich C Nadel, rosa: Seite 48
3. Cover Stich L Nadel, rosa: Seite 49

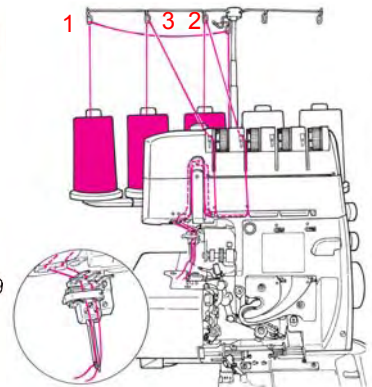
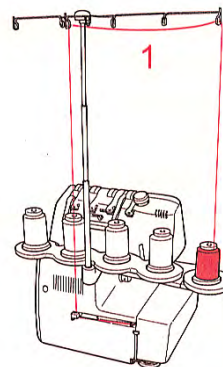
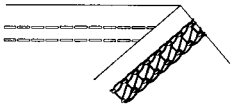

3 Faden Cover Stich Einfädeln (schmal C,R)

1. Kettenstich Greifer violette Markierung: Seite 46
2. Cover Stich R Nadel, rosa: Seite 47
3. Cover Stich C Nadel, rosa: Seite 48



Diagramme d'enfilage

Enfilage, point de chaînette

1. Enfiler le boucleur pour le point de chaînette (violet), véase pág.37
2. Enfiler l'aiguille pour le point de chaînette, repères brun (tension jaune), véase pág.38

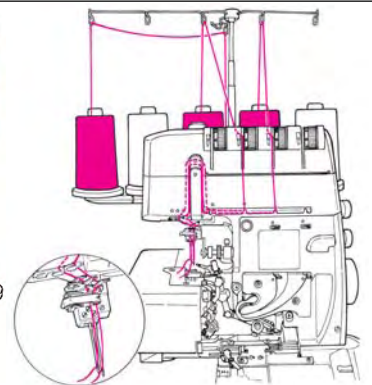
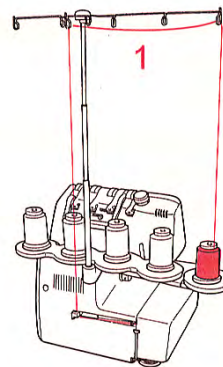
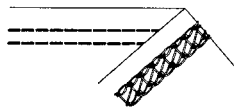
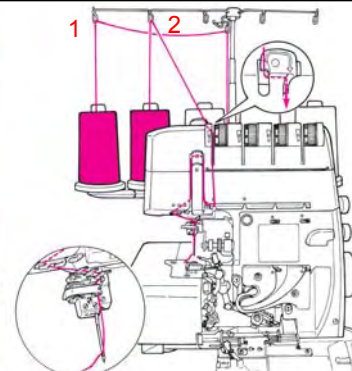
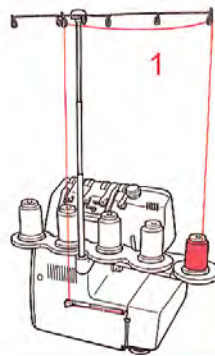
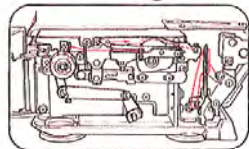

Surjet à 3 fils (aiguille gauche) + point de chaînette

1. Enfiler le fil supérieur, repère bleu, voir page 33
2. Enfiler le fil inférieur, repère rouge, voir page 34
3. Aiguille de droite, repère verte et tension verte, voir page 35
4. Enfiler le boucleur de chaînette (pourpre), voir page 37
5. Aiguille de chaînette, repères brun (tension jaune), voir page 38

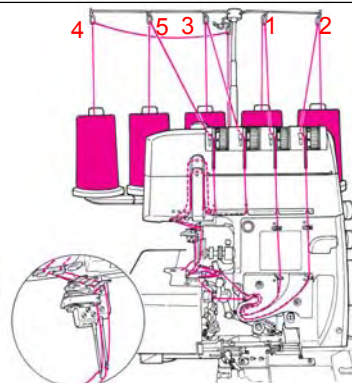
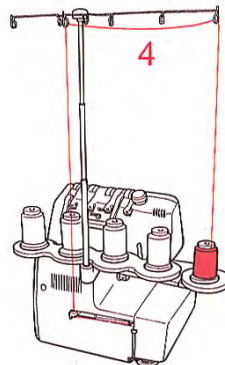
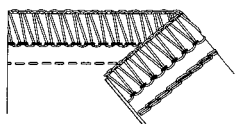

Surjet à 3 fils (aiguille droite) + point de chaînette

1. Enfiler le fil supérieur, repère bleu, voir page 33
2. Enfiler le fil inférieur, repère rouge, voir page 34
3. Aiguille de droite, repère verte, voir page 35
4. Enfiler le boucleur de chaînette (pourpre), voir page 37
5. Aiguille de chaînette, repères brun (tension jaune), voir page 38

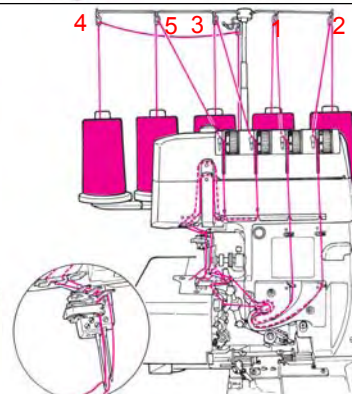
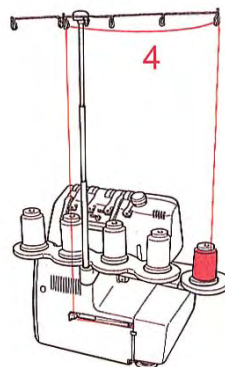
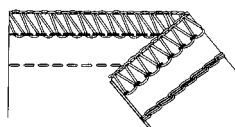

Surjet à 2 fils (aiguille gauche) + point de chaînette

1. Placer le recouvrement sur le levier du boucleur supérieur, voir page 21
2. Enfiler le fil inférieur, repère rouge, voir page 34
3. Aiguille de gauche, repère verte et tension verte, voir page 35
4. Enfiler le boucleur de chaînette (pourpre), voir page 37
5. Aiguille de chaînette, repères brun (tension jaune), voir page 38

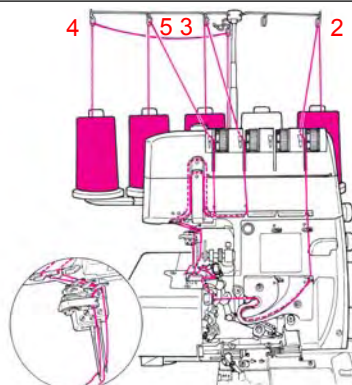
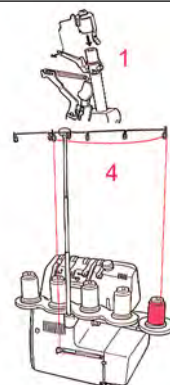
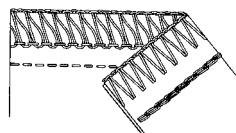

Surjet à 2 fils (aiguille droite) + point de chaînette

1. Placer le recouvrement sur le levier du boucleur supérieur, voir page 21
2. Enfiler le fil inférieur, repère rouge, voir page 34
3. Aiguille de droite, repère verte, voir page 35
4. Enfiler le boucleur de chaînette (pourpre), voir page 37
5. Aiguille de chaînette, repères brun (tension jaune), voir page 38

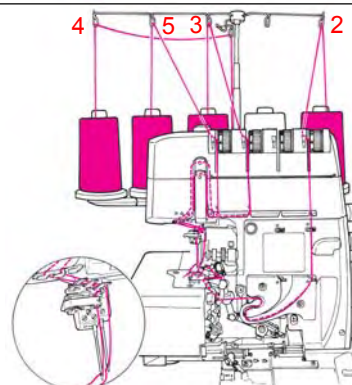
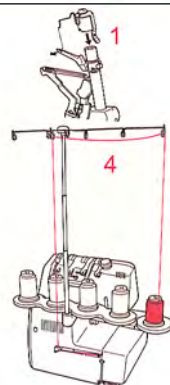
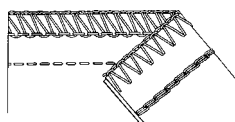

Enfilage pour le point enveloppant à 4 fils

1. Enfiler le boucleur de chaînette (pourpre), voir page 46
2. Point enveloppant l'aiguille R (rose), page 47
3. Point enveloppant l'aiguille C (rose), page 48
4. Point enveloppant l'aiguille L (rose), page 49

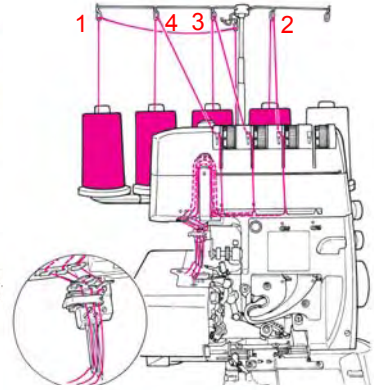
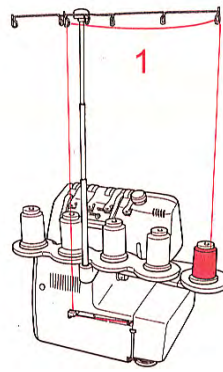
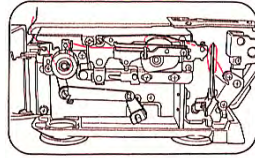
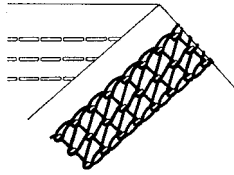

Enfilage pour le point enveloppant à 3 fils (large L,R)

1. Enfiler le boucleur de chaînette (pourpre), voir page 46
2. Point enveloppant l'aiguille R (rose), page 47
3. Point enveloppant l'aiguille L (rose), page 49

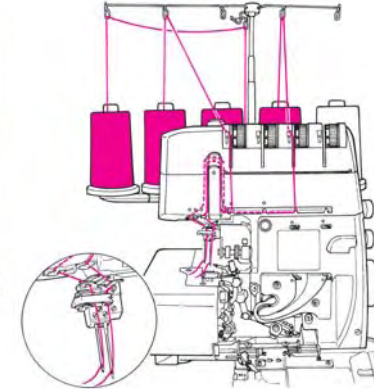
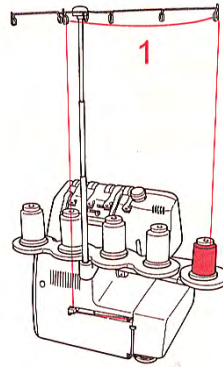
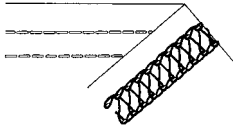

Enfilage pour le point enveloppant à 3 fils (étroit L,C)

1. Enfiler le boucleur de chaînette (pourpre), voir page 46
2. Point enveloppant l'aiguille C (rose), page 48
3. Point enveloppant l'aiguille L (rose), page 49

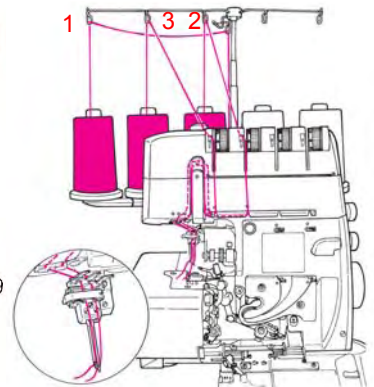
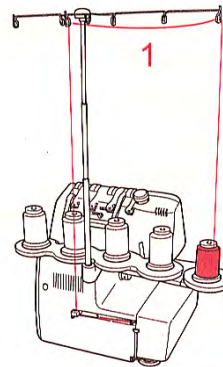
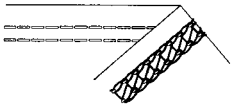

Enfilage pour le point enveloppant à 3 fils (étroit C,R)

1. Enfiler le boucleur de chaînette (pourpre), voir page 46
2. Point enveloppant l'aiguille R (rose), page 47
3. Point enveloppant l'aiguille C (rose), page 48

