

brother

*SERVICE MANUAL FOR
COVER STITCH MACHINE*

2340CV

CONTENTS

HOW TO USE THIS MANUAL.....	2
HOW TO ADJUST.....	3
Height of needle bar	3
Position of the lowerlooper	4
Timing of the double chain looper	5
Timing of the lowerlooper	6
Height of feed dog (with a differential feed dog).....	7
Feed timing.....	8
Height of presser bar	9
Thread tension adjustment.....	10
Position of thread take-up	11
Position of looper thread take-up.....	12
Adjustment and replacement for the timing belt	13
Changing the light bulb.....	14

HOW TO USE THIS MANUAL

This service manual is compiled as a guide for the repair and service of Brother Cover Stitch Machine model 2340CV. Almost all troubles or problems occurring on Homelock sewing machines which arise as the result of the user's lack of knowledge or experience can be solved by following instruction book. It should be followed carefully because many faults are caused by misuse or carelessness. We therefore recommend you to refer to the "Check list for better sewing" in the Instruction Book before you attempt any adjustment from this manual.

However, if it is necessary to adjust the mechanism, use this manual together with the PARTS CATALOGUE for each model. Find the fault in question in the Fault-finding chart and follow the corrective measures in this manual.

1. Adjust each model number circled in each illustration and instruction.
2. Symbols:

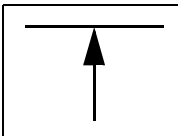
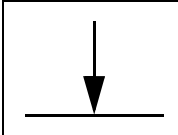
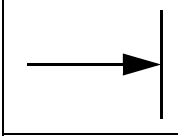
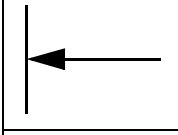
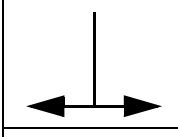
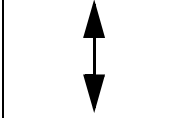
	Move the part to its highest position
	Move the part to its lowest position
	Move the part to the extreme right
	Move the part to the extreme left
	Move the part to the right or left
	Move the part up or down

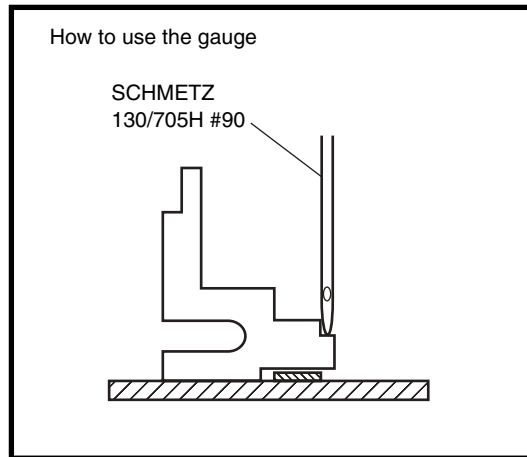
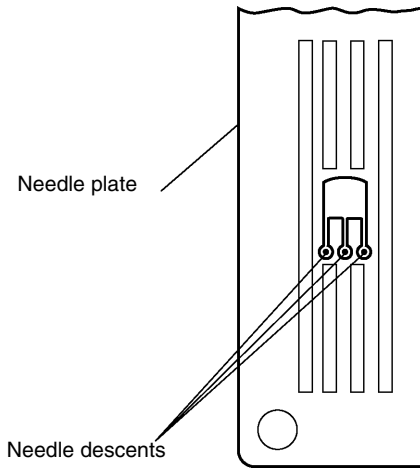
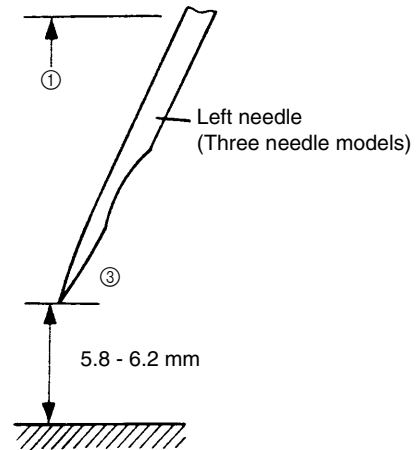
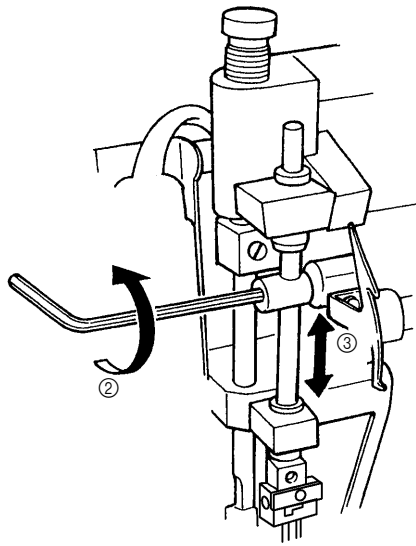

1. Raise the needle to its highest position.
2. Loosen the screw on the needle bar.
3. Position the needle bar so that the clearance between the point of the needle and the surface of the needle plate is as follows:
5.8 - 6.2 mm

NOTE • When making this adjustment, keep the needle bar at its highest position by holding the handwheel. Use the left needle of the three needles to adjust the height. After completing adjustment, check that the needle lowers to the center of the needle descents.

PARTS CODE FOR GAUGE: XB1282001

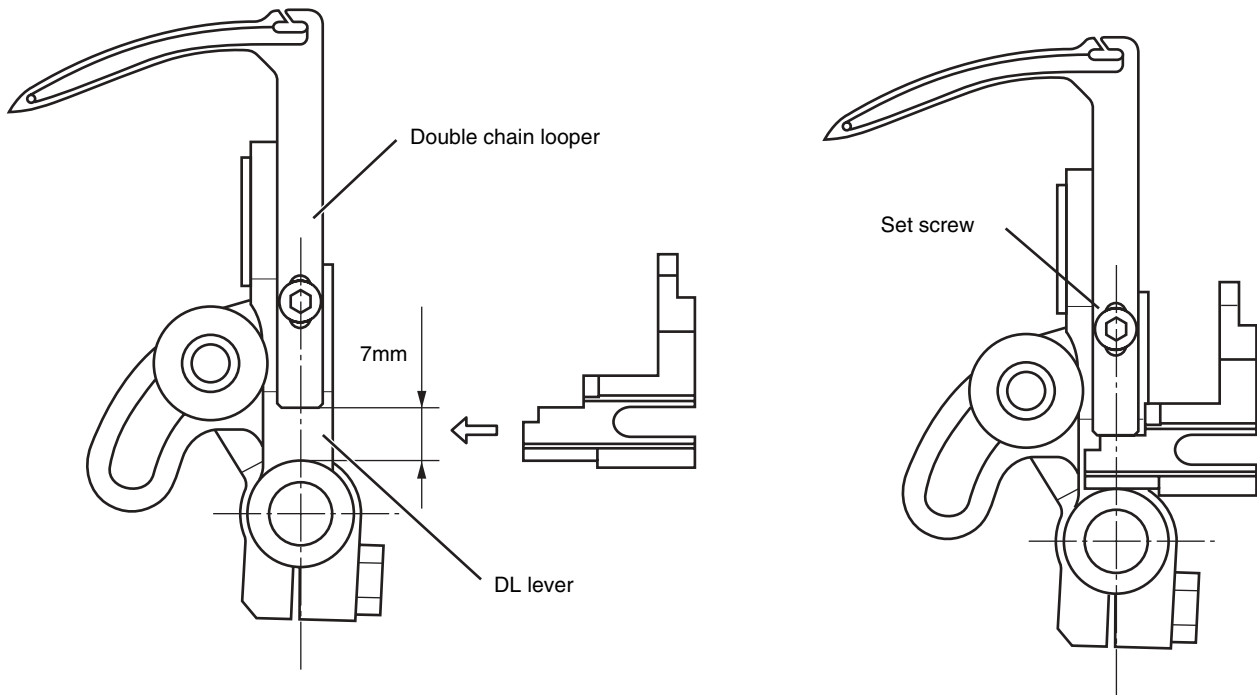

1. Before adjusting the timing, position the double chain looper correctly.
2. Too much adjustment will cause damage to other parts or cause the needle to skip stitches.

How to use the gauge

1. Position the gauge as shown in the illustration.
2. Firmly tighten the screw.

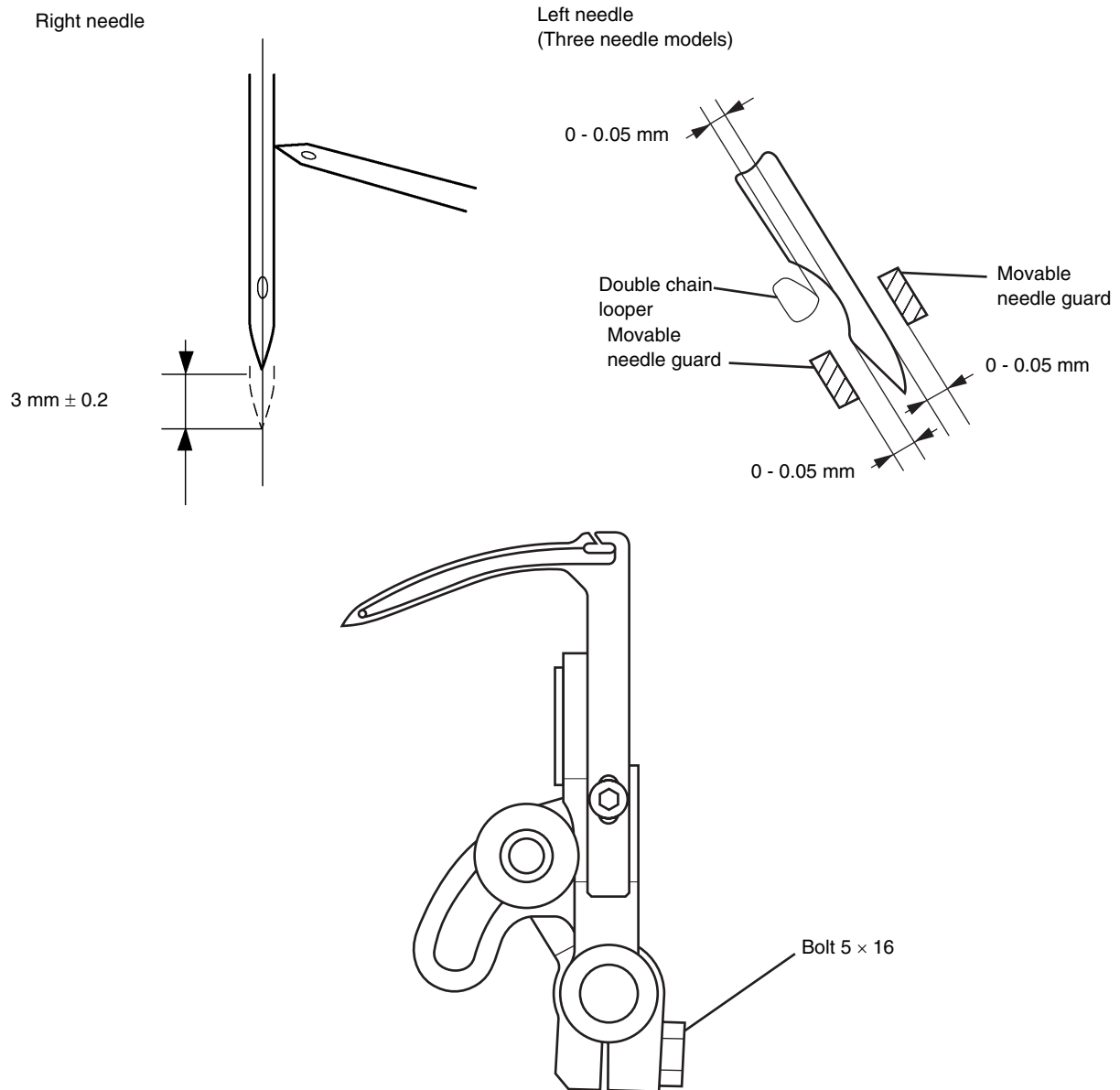

Adjust the needle and double chain looper

1. When the needle is raised to 2.8 - 3.2 mm above its lowest position, place the pointed end of the double chain looper against the right side of the needle. The point of the double chain looper should be between 0 - 0.05 mm from the needle.
2. Firmly tighten bolt 5 × 16

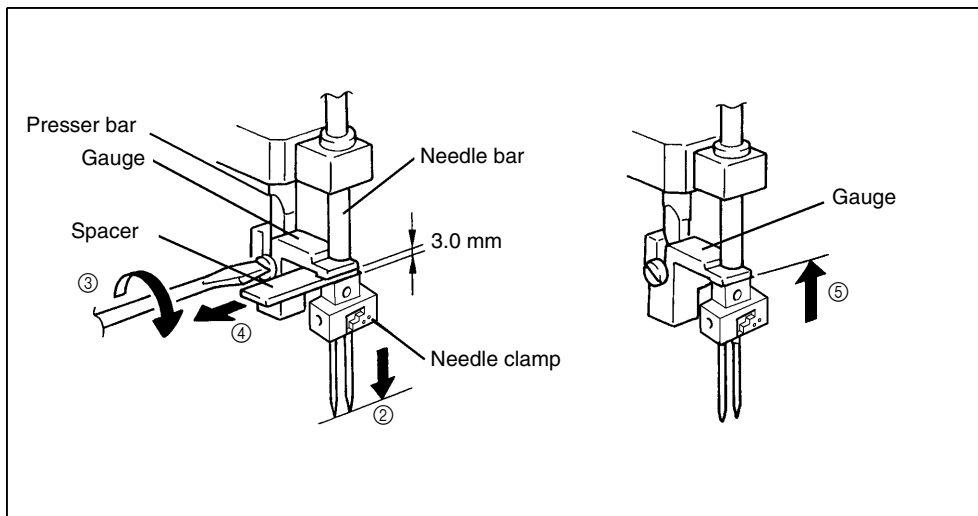

How to use the gauge

1. Raise the presser bar and remove the presser foot and presser foot holder.
2. Lower the needle bar to its lowest position.
3. Position the spacer and gauge and tighten the screw.
4. Remove the spacer.
5. Raise the needle bar until the needle clamp contacts the gauge. Continue making the adjustment described on the previous page. (The spacer is 3.0 mm thick.)

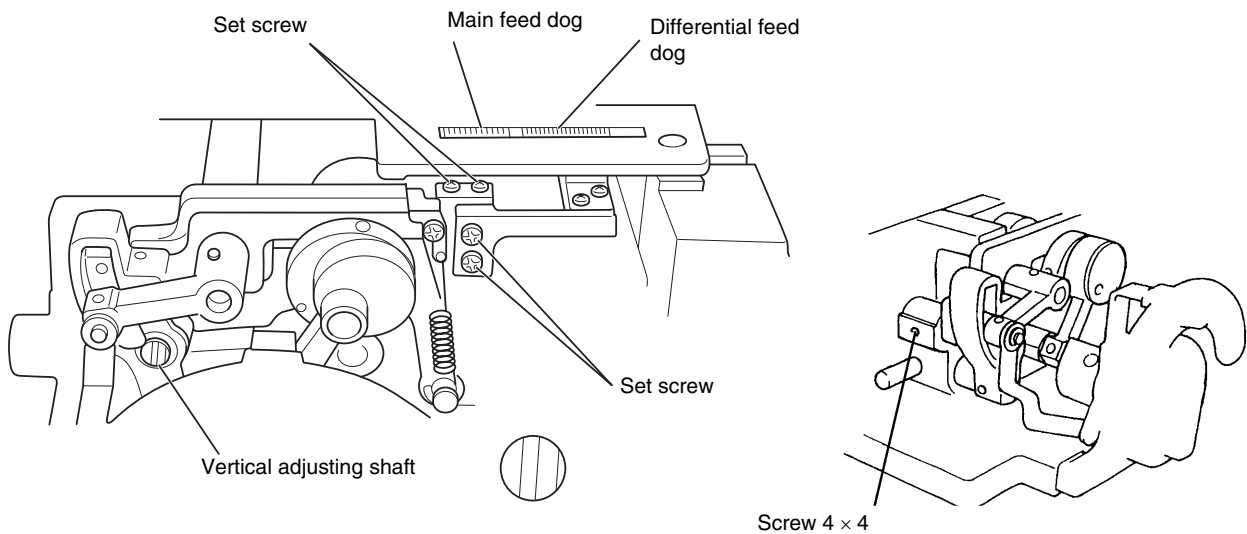

Adjustment for height of main feed dog

1. Open the cloth plate cover, and raise needle at its highest position by turning handwheel.
2. Set the sewing pitch at "3".
3. Loosen screw 4 × 4 of vertical adjusting shaft.
4. Use a gauge to adjust the height of the feed dog so that the tips of the teeth are 0.9 - 1.1 mm above the surface of the needle plate while turning the vertical adjusting shaft with a screwdriver.
5. After adjustment, tighten screw 4 × 4 of vertical adjusting shaft securely.

- NOTE**
- Stitches will tend to pucker in fine fabrics or feed dog will touch needle plate, in case feed dog reaches to higher position.
 - Fabrics will not be fed sufficiently or feed dog will touch other parts like double chain looper, in case feed dog reaches to lower position.
 - Set the cut mark on the vertical adjusting shaft to the front, and then adjust the vertical adjusting shaft.

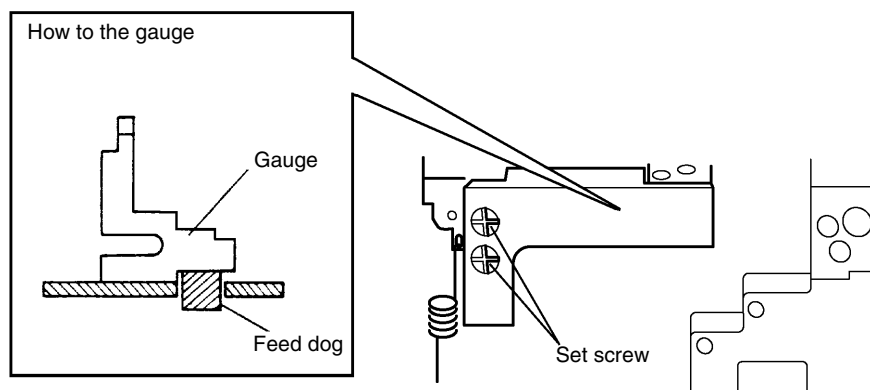

Adjustment for height of differential feed dog

Differential feed dog should be the same level as upper surface of needle plate when main feed dog goes down and reaches the same level as upper surface of needle plate. Adjust by loosening set screw of differential feed dog.

- NOTE**
- Adjust at position of "1.0" of feed ratio.
 - Differential feed dog should not be inclined when tightening set screw of differential feed dog.
 - In case difference between height of main feed dog and differential feed dog is too much, fabrics will not be fed correctly

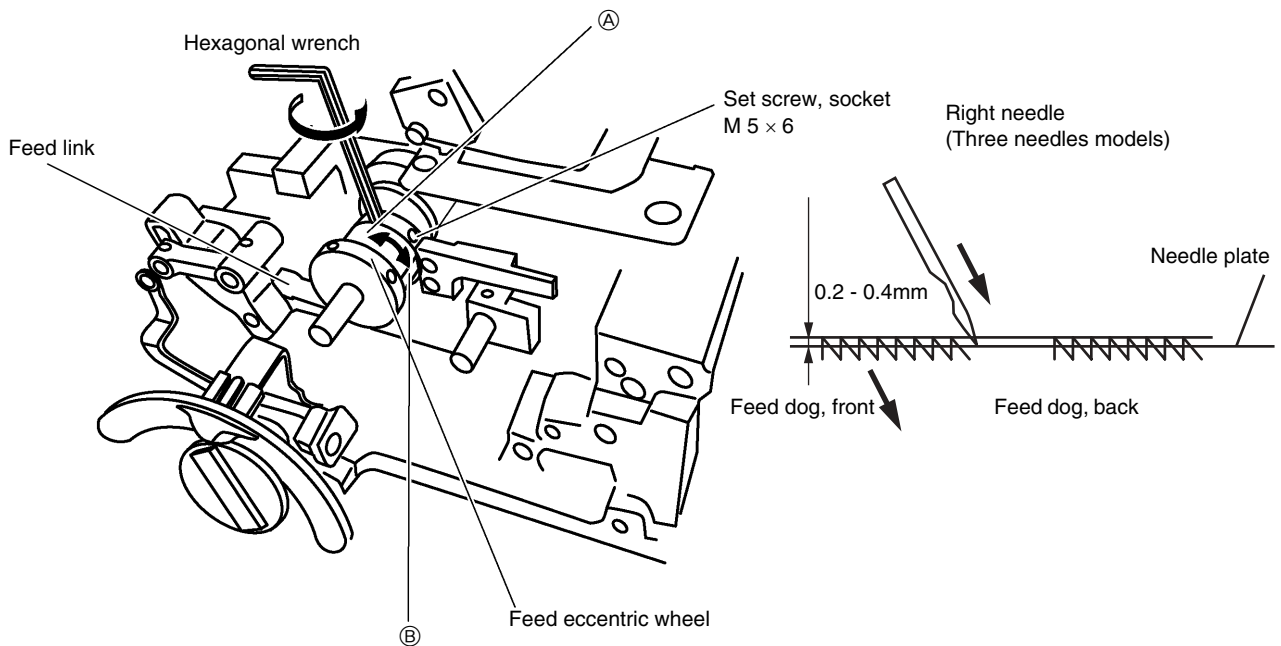

The standard timing of the feeding: Main feed dog should be at the same level as upper surface of needle plate when needle goes down and point of it touches upper surface of needle plate.

As the needle is descending and about to enter the needle plate hole, the feed dog must be positioned as shown in the illustration.

NOTE • Before the adjustment, check the Height of the feed dog and set the "Sewing pitch" at "3".
• Fabrics will not be fed straightly in case feed dog is inclined.

1. Open the cloth plate cover and loosen the set screw, socket M 5 × 6 (two) of the feed eccentric wheel by means of a hexagonal wrench.
2. Turn the feed eccentric wheel to adjust the timing as shown in the illustration.
 - In case of early timing, in other words when the feed dog is still positioned over the needle plate, turn the wheel in direction Ⓐ.
 - In case of late timing, in other words when the feed dog is already positioned under the needle plate, turn the wheel in direction Ⓑ.
3. Tighten the set screw, socket M 5 × 6 (two) well.

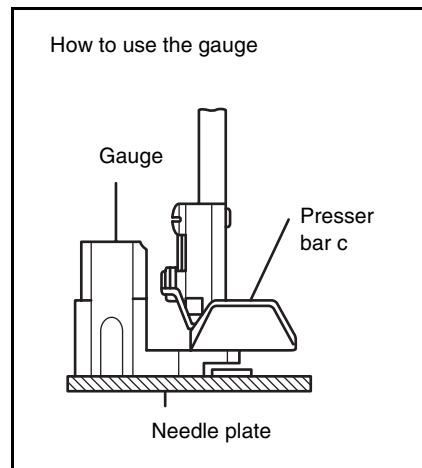
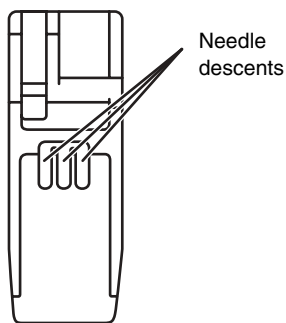
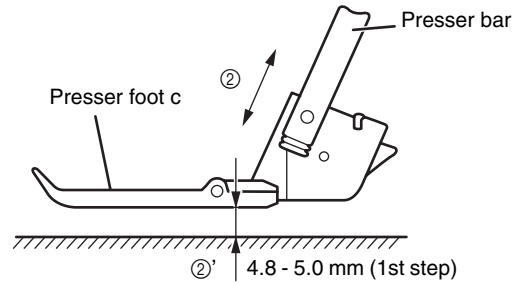
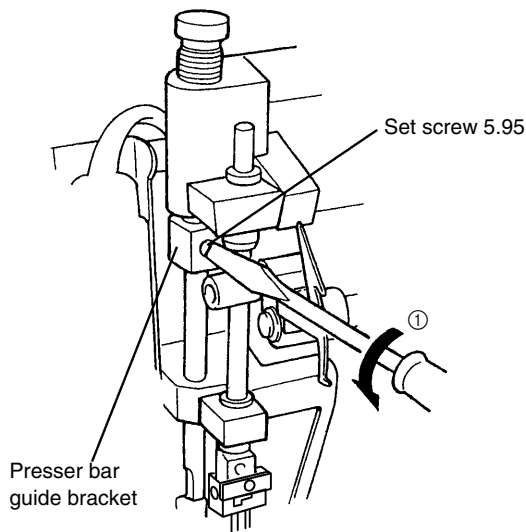

Before adjustment, remove the panel assembly. Then turn the handwheel and raise the needle to its highest position.

1. Raise the presser lever and loosen the set screw 5.95 securing the presser bar winding.
2. To adjust the height of the presser bar, raise the presser lever, and, at the point where the presser bar is horizontal, raise or lower it until the first step is 4.8 - 5.0 mm above the needle plate. Check also to make sure that the needle descents of the presser bar are not noticeably out of alignment with the needle descents of the needle plate.
3. After the adjustment has been completed, tighten the set screw 5.95 securely that holds the presser bar winding in place.

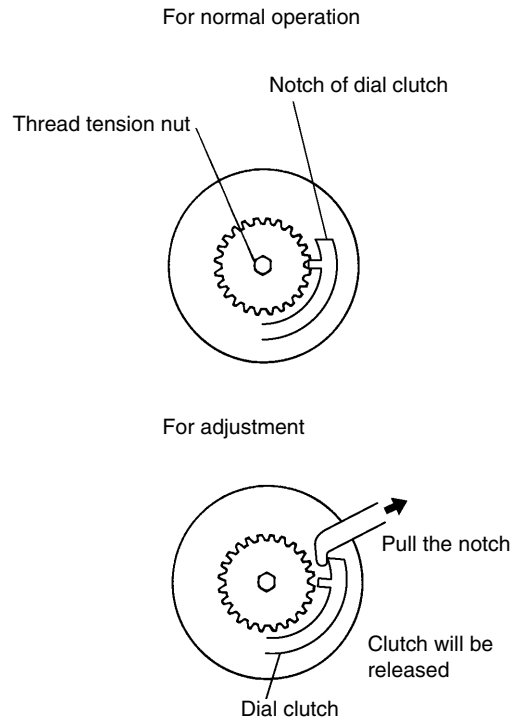
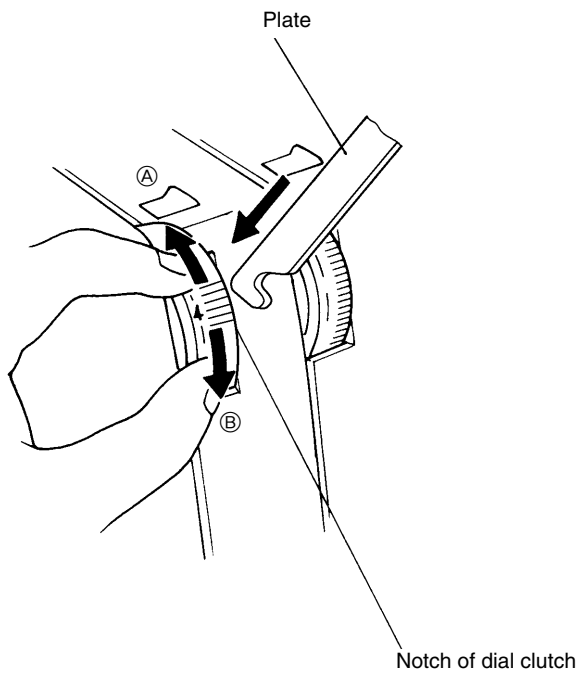

1. Set the thread tension dial to "4" on the dial scale.
2. Insert a plate of approx. 0.5 mm (0.02 in.) of thickness into the right side slot of the thread tension dial "4" position on the dial scale and pull the notch of the dial clutch.
Then while holding the plate, turn the dial to adjust the thread
 - Direction ① : increase tension
 - Direction ② : decrease tension

PLATE: XB1037001

1. Lower the needle to its lowest position.
2. Loosen the set screw and position the thread take up below the thread retainer by 0 - 1.5 mm.

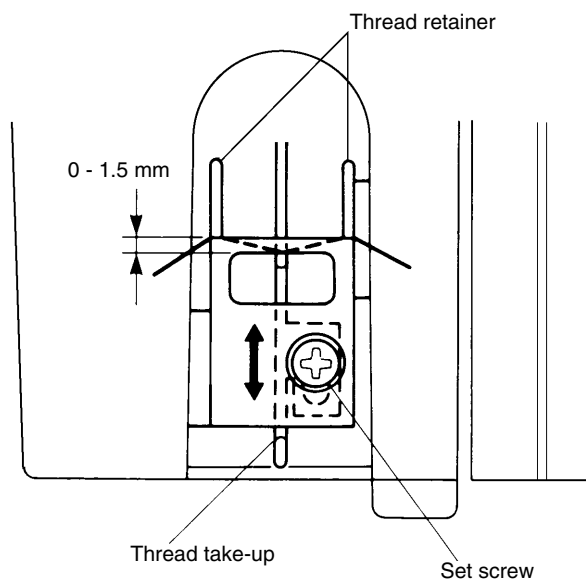

1. Loosen the thread take-up set screw.
2. Turn the pulley until the thread take-up is at its highest position, and adjust the distance from the F-cover hinge to the thread take-up as shown in the illustration below.
3. After completing adjustment, tighten the DL thread take-up set screw.

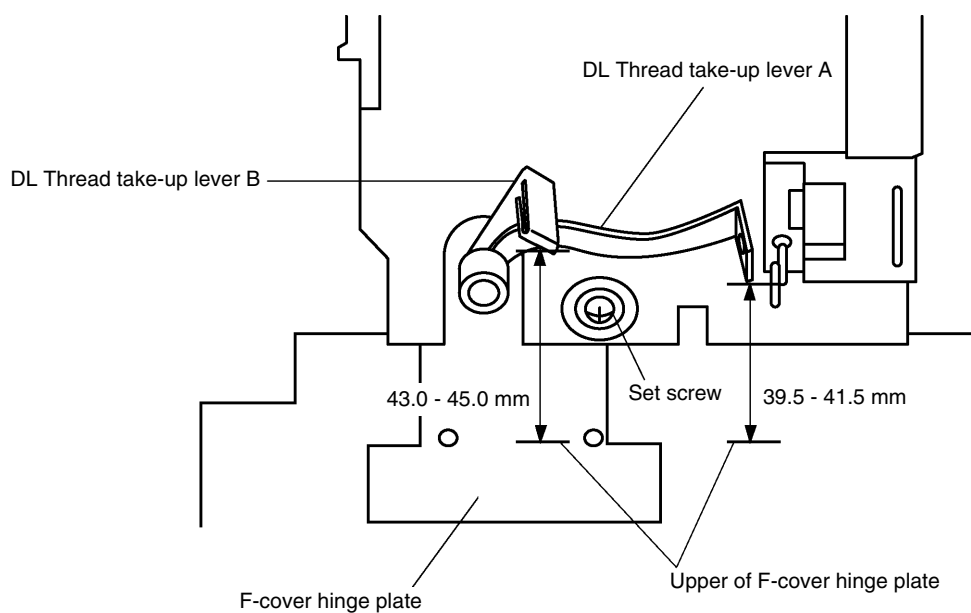

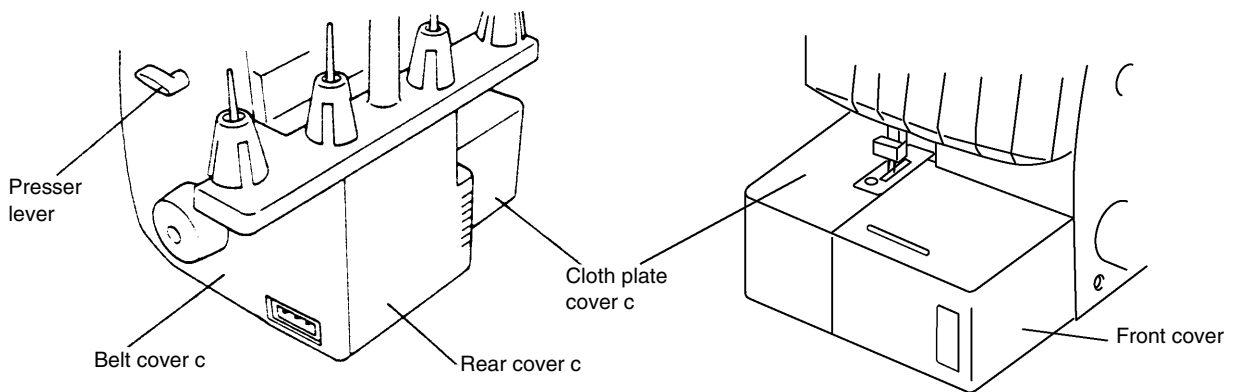

1. Remove the the cloth plate cover c.
2. Remove the presser lever.
3. Slide the belt cover c downward to remove it.
4. Remove the rear cover c.

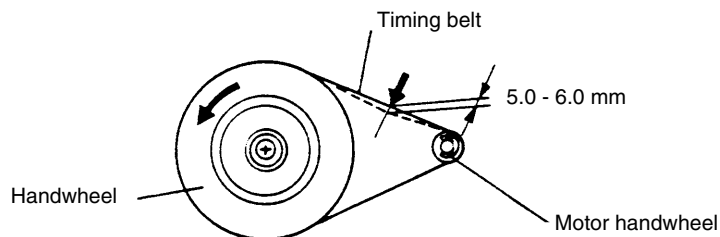
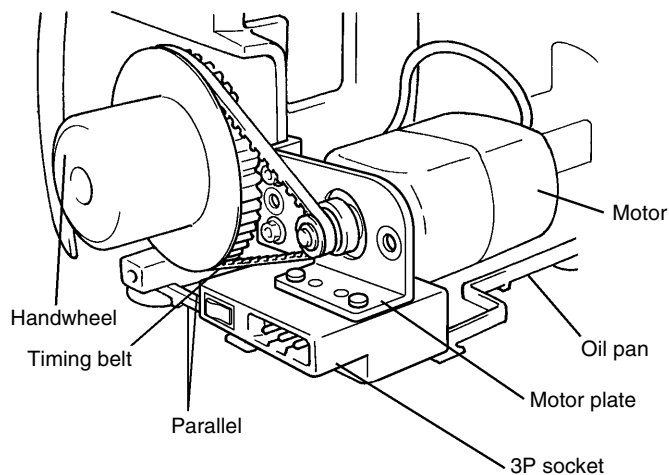

5. Adjust the belt tension by moving the motor plate right and left so that the belt can be pushed down 5.0 - 6.0 mm when applying a pressure of 500g.

NOTE • When the belt is worn, replace it in the same manner.
 • The 3p socket and the oil pan should be parallel.

6. After adjustment, assemble the covers in the reverse order.

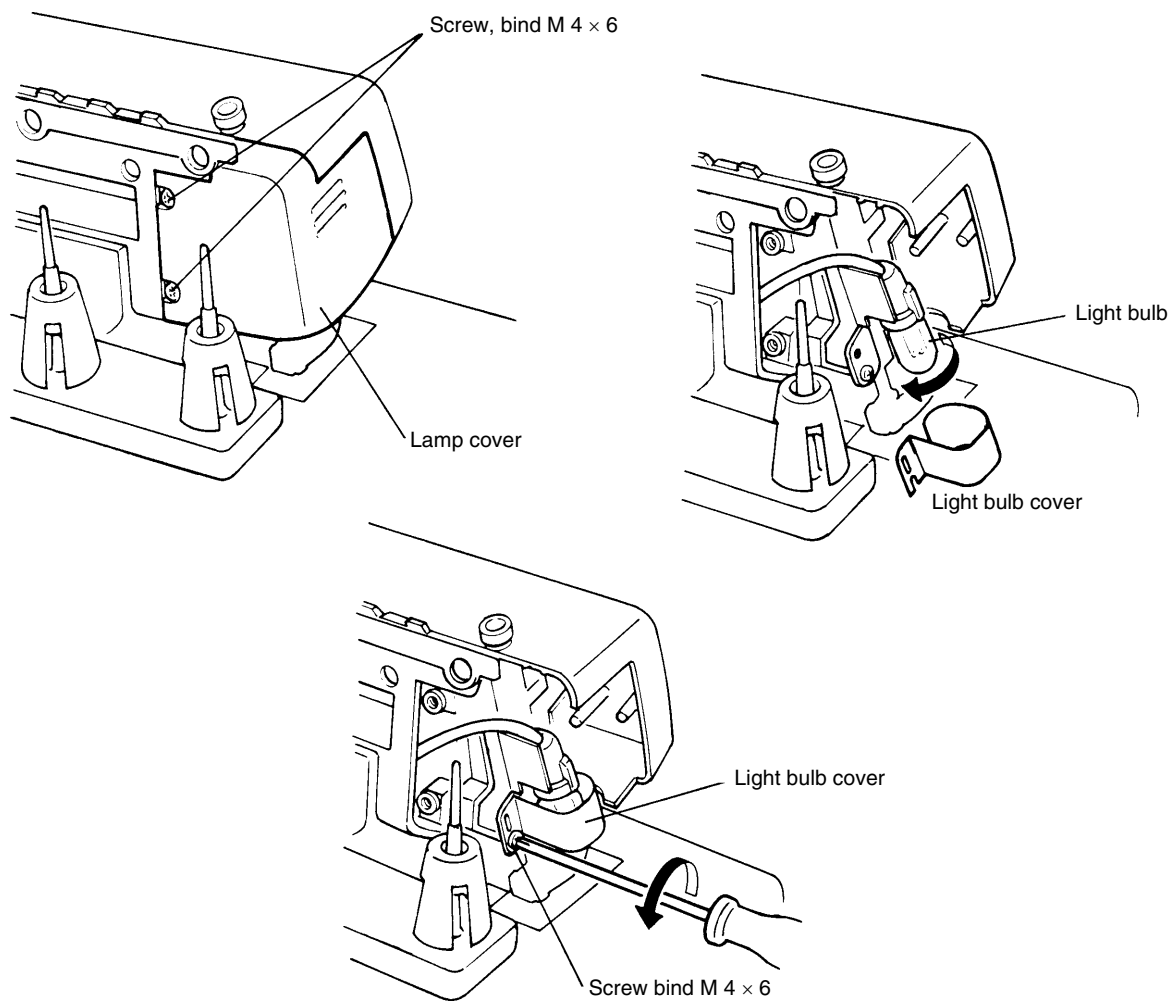
**Caution!**

Always be sure to turn off the power before carrying out the following operation.

Changing the light bulb

- Remove the lamp cover as shown in the illustration.
- Loosen the light bulb cover set screw, pull up the light bulb cover and remove it.
- Take out the light bulb and replace it with a new one.
- After replacing the light bulb , assemble the parts in the reverse order.

2340CV

2340CV
37J03HF884500